

Der Franzose

P.R. 810 DERNIÈRE ÉDITION
**CATALOGUE
DE PIÈCES
DE RECHANGE**

R 2134 , R 2135

RENAULT

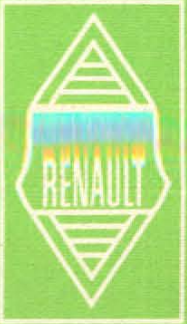

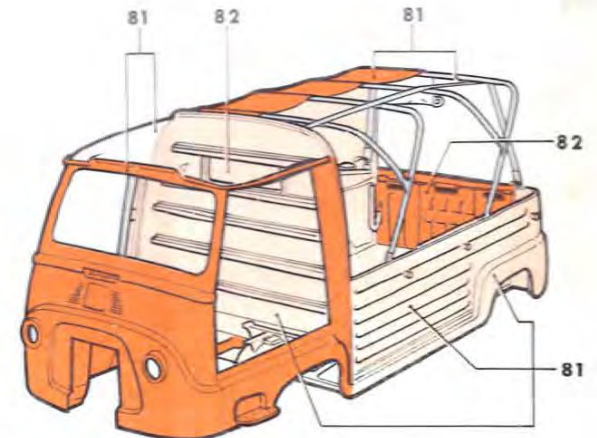
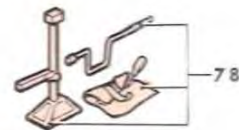
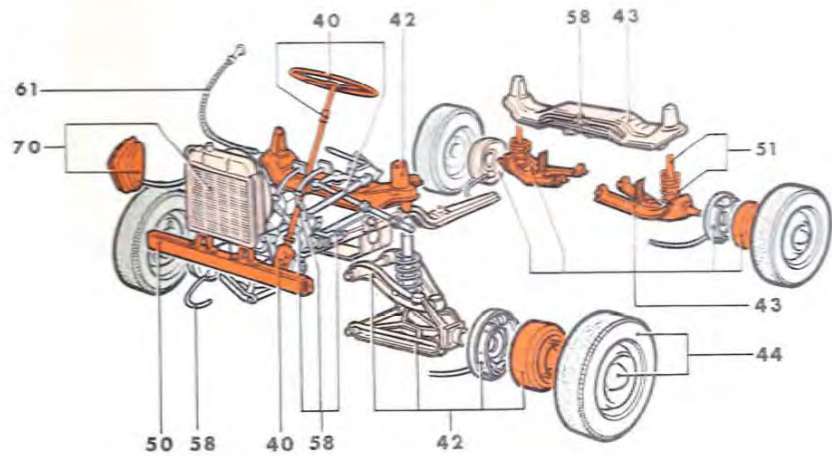
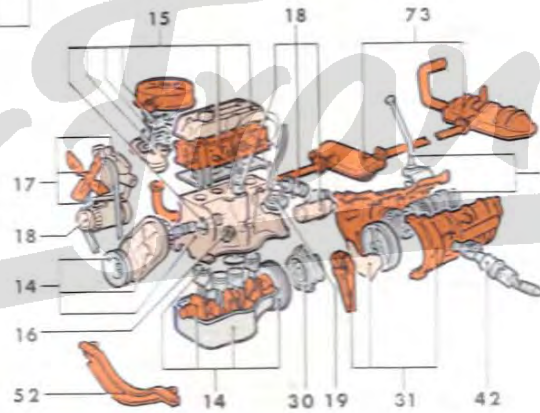
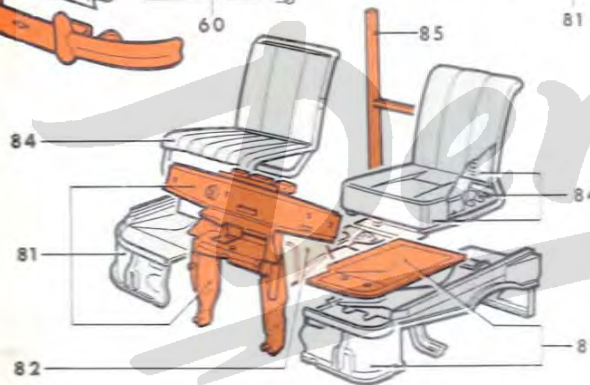
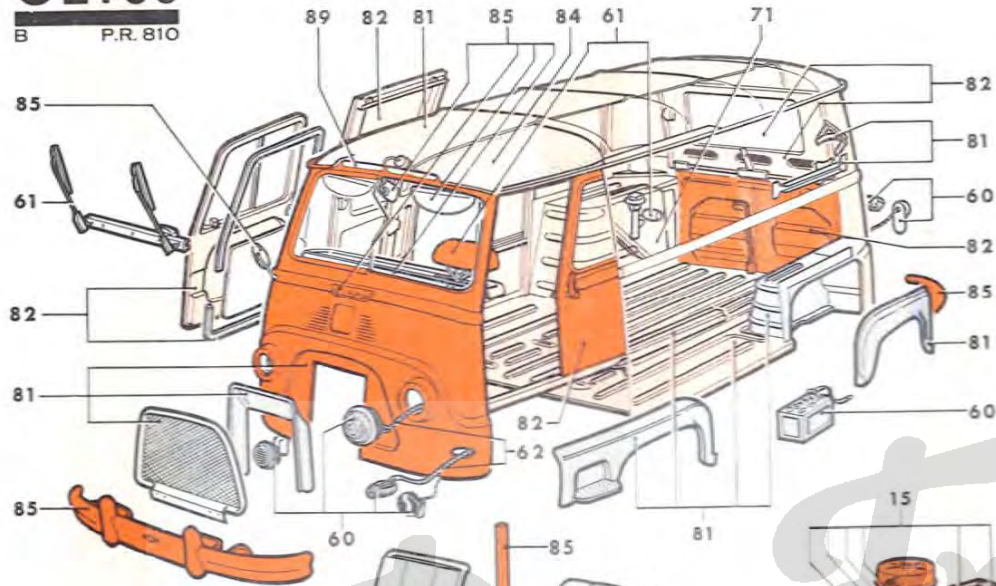



01.10 --- A

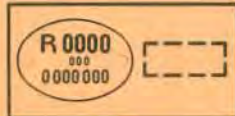

02.01 --- A



03.01 ---



05.01 --- A

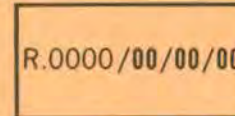

05.40 --- B



06.01 --- A

14

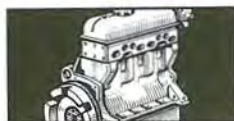

14.01 B

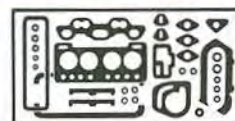

14.05 B

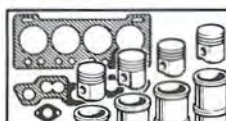

14.20 B

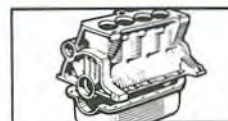

14.30 B

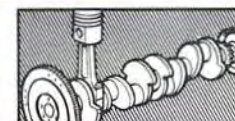

14.40 B



14.50 B

14

15



15.01.1 B - 15.01.2 B



15.10 B



15.20 B



15.30 B



15.40 B - 15.41.1 B - 15.41.2 B
15.42 B - 15.43 B



15.45 B

15

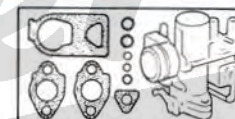

15.48 B



15.70 B

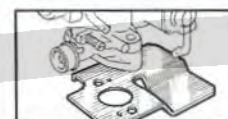

15.75 B



15.80 B

16



16.01 B



16.10 B

16

17

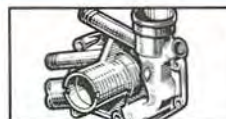

17.01 B

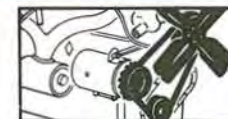

17.50 A

17

18

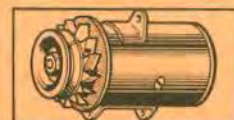

18.10 B - 18.13 B
18.16 B

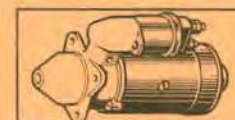

18.30.1 B - 18.30.2 B
18.33 B



18.40 B - 18.43.1 B
18.43.2 B - 18.45 A



18.60 B



18.70 B



18.80 B

18

19



19-01B

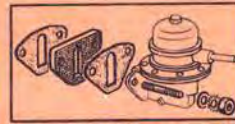

19-20B

19

30

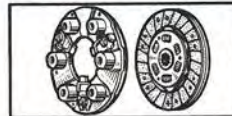

30-01B-30-05A

30

31

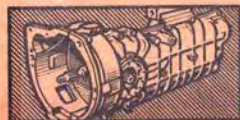

31-01B — 31-10 B
31-13 B



31-15B

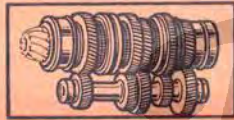

31-20 B



31-30B



31-40 B



31-50 B

31

40



40-01B

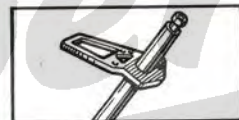

40-10 B



40-15A

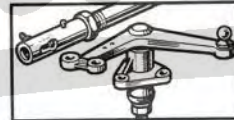

40-20 B

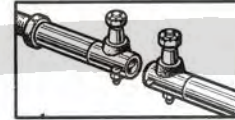

40-30 B

40

42



42-01 B

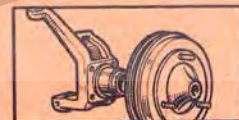

42-10 B

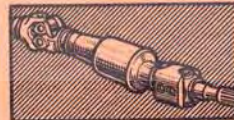

42-20 B — 42.25 A



42-30 B



42-35 B

42

43



43-01 B

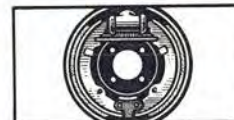

43-10 B

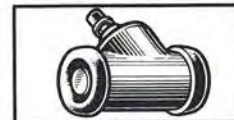

43-15 B

43

44



44-01 B



44-10 B

44

50

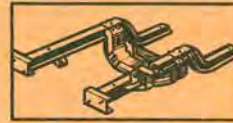

50-10 B-50-20 B

50

51

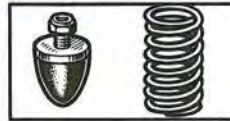

51-01 B

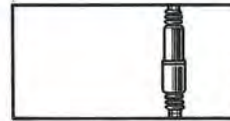

51-10 B

51

52



52-01 B

52

58



58-01 B-58.03 A

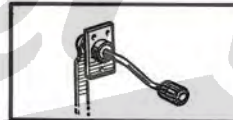

58-05 B



58-10 B-58-15 B

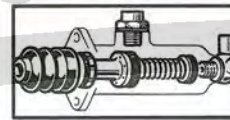

58-20 B-58-22 B

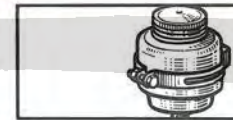

58-25 B

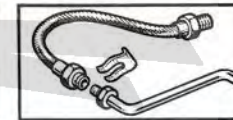

58-30 B

58

60



60-01 B



60-05.1 B-60-05.2 B
60-07 B



60-10 B



60-13 B



60-25 B



60-28 B

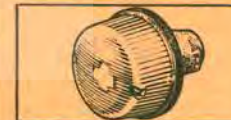

60-31 B

60



60-35 B



60-37 B

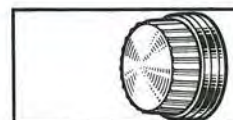

60-40 B

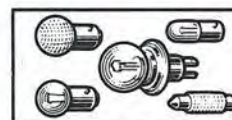

60-45 B



60-55 B-60-61 B



60-58 B-60.65A

61



61-01 B-61-04 B



61-10 B

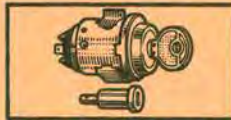

61-16 B-61-17.1 A
61-17-2 A



61-18 B



61-20 B



61-28 B



61-30 B-61-32 B
61-34 B

61

61

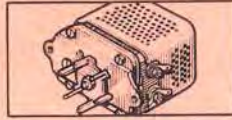

61-36 B



61-38 A



61-42 B



61-45 B

61

62

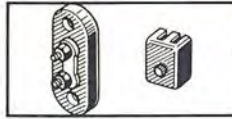

62-30 B



62-40 B

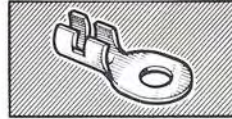

62-43 B

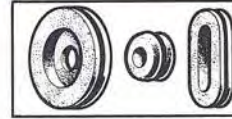

62-46 B

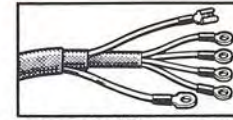

62-50-1 B-62-50-2 B-62-51-1 A
62-51-2 A-62-52-1 A-62-52-2 A

62

70

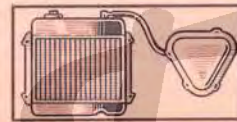

70-01 B

70

71



71-01 B

71

73

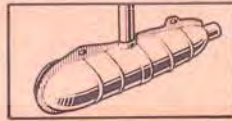

73-01 B - 73-10 B - 73.20 A

73

78

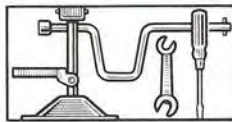

78-01 B

78

81



81-02-1 B - 81-02-2 B



81-05 B - 81-10 B



81-17 B - 81-20 B



81-25 B



81-30 B



81-35 A



81-36 A

81

81

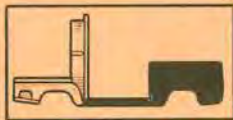

81-38 A



81-40 B

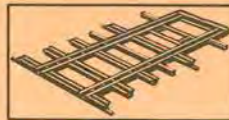

81-45 B



81-46 B

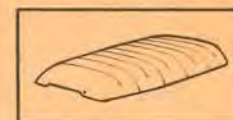

81-50 B



81-52 A



81-67 B

81



81-70 A

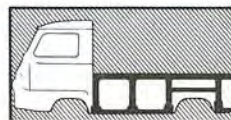

81-75 A

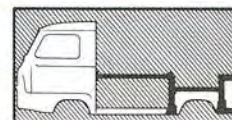

81-77 A



81-80 B

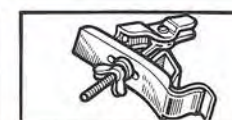

81-90 A

82



82-05 B - 82-10 B



82-15 B



82-21 B



82-25 B



82-30 A



82-40 B



82-50 B

82



82-55 B

84



84-01 A



84-02 B - 84-05 B
84-10 A

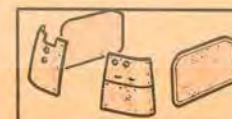

84-30 B

84

85



85-01 B



85-20 B



85-40 B



85-45 B



85-50 B



85-55 A

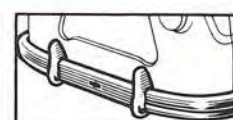

85-80 B

85



85-85 B



85-90 B

89



89-01 B

89

100



100-01 ---

100

120

BC23100252	5201	04	80240
BC23100252	5202	04	80240
BC23100302	1430	04	80240
BC23100302	1430	10	80240
BC23100302	1470	02	80240
BC23100302	1475	02	80240
BC23100302	3105	10	80240
BC23100302	3130	01	80240

120-01 --- B

120

130



130.50

130

Der Franzose



R 2134, R 2135

01.10
A P.R. 810

Régie nationale des usines Renault
8-10 av. Emile-Zola B.P. 103-92 Boulogne-Billancourt,
téléphone: Paris(1) 603-13-13 adresse télégraphique
Renofer-Paris, telex Paris 20094 - Boulogne 26 088
R.C. Paris 55 b 8620 n° d'entreprise 26192 012 9001

1	2	3	4	5	6	1970
7	8	9	10	11	12	

<p>FRANÇAIS</p> <p>Catalogue de pièces de rechange</p> <p>P.R. 810</p> <p>DERNIÈRE ÉDITION</p> <p>Annule et remplace : P.R. 810 - 1^e Edition</p>	<p>DANSK</p> <p>Reservedelskatalog</p> <p>P.R. 810</p> <p>SIDSTE UDGAVE</p> <p>Ophæver og erstatter : P.R. 810 - 1. Udgave</p>	<p>DEUTSCH</p> <p>Ersatzteilkatalog</p> <p>P.R. 810</p> <p>LETZTE AUSGABE</p> <p>Annulliert und ersetzt : P.R. 810 - 1. Ausgabe</p>	<p>ENGLISH</p> <p>Spare parts catalogue</p> <p>P.R. 810</p> <p>LATEST EDITION</p> <p>Cancels and replaces : P.R. 810 - 1st Edition</p>
<p>ESPAÑOL</p> <p>Catálogo de piezas de repuesto</p> <p>P.R. 810</p> <p>ÚLTIMA EDICIÓN</p> <p>Anula y sustituye a : P.R. 810 - 1^a Edición</p>	<p>ITALIANO</p> <p>Catalogo dei pezzi di ricambio</p> <p>P.R. 810</p> <p>ULTIMA EDIZIONE</p> <p>Anulla e rimpiazza : P.R. 810 - 1^a Edizione</p>	<p>NEDERLANDS</p> <p>Onderdelenboek</p> <p>P.R. 810</p> <p>LAATSTE UITGAVE</p> <p>Vernietigen en vervangen : P.R. 810 - 1^e Uitgave</p>	<p>SVENSKA</p> <p>Reservdelskatalog</p> <p>P.R. 810</p> <p>SISTA UPPLAGAN</p> <p>Annulerar och ersätter : P.R. 810 - 1 Upplagan</p>



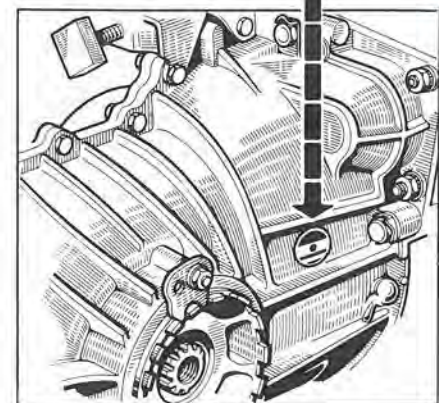
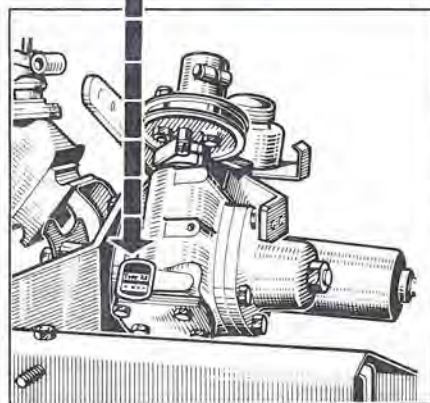
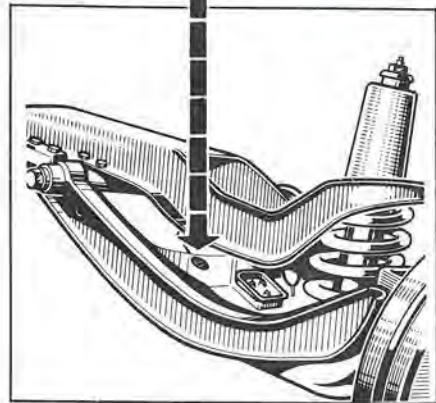
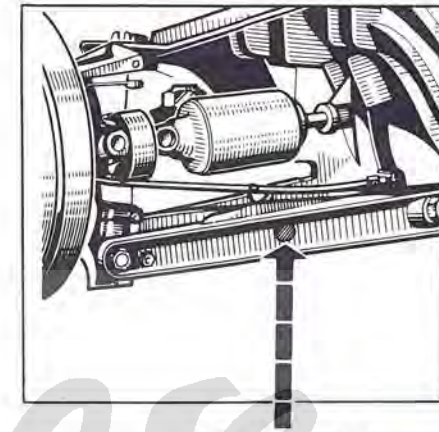
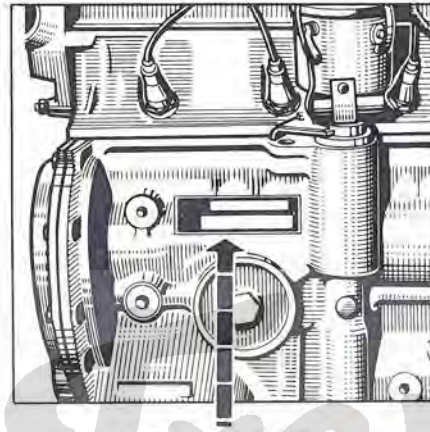
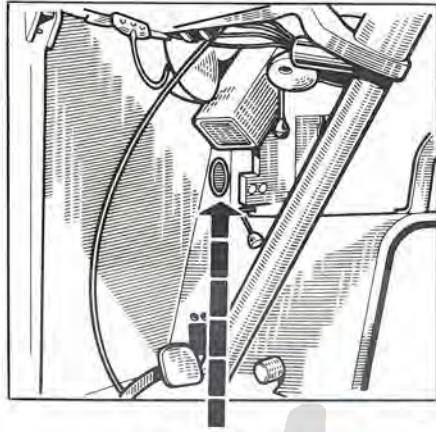

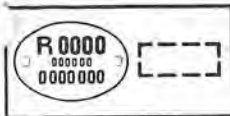

02.02

1.

R 0000

2.

/0...

3.

VEH. n° 0...

4.

MOT. n° 0...

5.

80 23 060 152

6.

43.30

C P.R.0..



02.02

FRANÇAIS

POUR COMMANDER DES PIÈCES DE RECHANGE, VEUILLEZ INDIQUER :

- 1 Le type du véhicule
- 2 Le numéro de l'équipement
- 3 Le numéro de fabrication du véhicule
- 4 Le type et le numéro de fabrication de l'organe
- 5 Le numéro de la pièce
- 6 Facultatif : le numéro du catalogue, le numéro de la planche

Si les autres N°s du véhicule sont détruits : le numéro dans la série du type (voir carte de garantie)

DANSK

VED BESTILLING AF RESERVEDELE BEDES DE VENLIGST OPGIVE :

- 1 Vogntypen
- 2 Udstyrsnummeret
- 3 Serienummeret
- 4 Fabrikationsnummeret på del samlede aggregat
- 5 Delnummeret
- 6 Undtagelsesvis Katalognummeret Planchenummeret

Hvis numrene på vognen er ødelagte : opgiv chassisnummer (se garantibeviset)

DEUTSCH

BEI DER BESTELLUNG VON ERSATZTEILEN IMMER ANGEBEN :

- 1 Der Typ des Fahrzeuges
- 2 Die Ausrüstungsnummer
- 3 Die Fabrikationsnummer des Fahrzeuges
- 4 Typ und Fabrikationsnummer des Aggregats
- 5 Die Teilnummer
- 6 Wenn erforderlich : Die Nummer des Kataloges. Die Nummer der Bildtafel

Wenn die anderen Fahrzeugnummern nicht mehr zu ermitteln sind : die Fahrgestellnummer (siehe Garantiekarte)

ENGLISH

WHEN ORDERING SPARE PARTS, WILL YOU PLEASE MENTION :

- 1 The vehicle type
- 2 The version number
- 3 The vehicle manufacturing number
- 4 The unit type and manufacturing number
- 5 The part number
- 6 And optionally : the catalogue number and page number

If the other vehicle numbers have been destroyed, the chassis number (see guarantee card)

ESPAÑOL

AL SOLICITAR PIEZAS DE REPUESTO, SIRVANSE INDICAR :

- 1 El tipo del vehículo
- 2 El número de su equipo
- 3 El número de fabricación del vehículo
- 4 El tipo y el número de fabricación del órgano
- 5 El número de la pieza
- 6 Facultativo el número del catálogo, el número de la lámina

Si los otros N°s del vehículo están destruidos : el número en la serie del tipo (véase el certificado de garantía)

ITALIANO

NELLE ORDINAZIONI DEI PEZZI DI RICAMBIO RICORDATE DI INDICARE :

- 1 Il tipo del veicolo
- 2 Il numero dell'equipaggiamento
- 3 Il numero di fabbricazione del veicolo
- 4 Il tipo ed il numero di fabbricazione dell'organo
- 5 Il numero del pezzo
- 6 Facoltativamente il numero di catalogo, il numero dell'illustrazione

Nel caso in cui gli altri Numeri del veicolo siano andati distrutti : il numero nella serie del tipo (vedere tessera di garanzia)

NEDERLANDS

GELIEVE BIJ HET BESTELLEN VAN ONDERDELEN HET VOLGENDE OP TE GEVEN :

- 1 Het wagentype
- 2 Het uitrustingsnummer
- 3 Het fabricagenummer van de wagen
- 4 Het type en het fabricagenummer van het orgaan
- 5 Het onderdeelnummer
- 6 Naar goedvinden : het onderdelenboeknummer, het afbeeldingsnummer

Wanner de andere nummers van de wagen niet meer leesbaar zijn, moet opgegeven worden : het chassis-nummer (zie het garantiebewijs)

SVENSKA

VID BESTÄLLNING AV RESERVDEL OMBEDS NI ATT ANGE :

- 1 Vagntyp
- 2 Utrustningsnummer
- 3 Vagnens fabrikationsnummer
- 4 Enhetens typbeteckning och fabrikationsnummer
- 5 Delnummer
- 6 Dessutom och valfritt : Katalognummer, Plansnummer

Om dessa uppgifter saknas eller ovala plåten försvunnit, uppges det på garantikortet stämplade chassisnumret

INTRODUCTION

Le présent document contient tous les ensembles et pièces détachées et vendables en rechange; il permet de déterminer avec précision leurs numéros et de les identifier facilement par les illustrations.

Ces ensembles et ces pièces sont répartis par **planche** suivant l'organe ou l'élément d'organe auquel ils se rattachent.

Chaque **planche** est identifiée par un numéro à 4 chiffres dont les deux premiers correspondent à un code organe déterminé; elle peut être caractérisée par une variante ou un point de départ dans le cas où elle s'identifie avec une planche similaire.

Une planche se compose:

de l'illustration des pièces et ensembles contenus dans la planche et qui diffèrent de forme; à chaque pièce illustrée correspond un ou plusieurs numéros de pièces caractérisés entre eux par une variante ou un signe codifié.

et, éventuellement, de **tableaux** comportant des renseignements complémentaires tels que points de départ et consignes. Ces tableaux figurent soit en bas de l'illustration, soit sur une page annexe à l'illustration.

Remarque: la signification des signes et expressions codifiés utilisés dans chaque planche, est indiquée dans la planche n° 05.

Un **répertoire numérique** en fin de catalogue donne la correspondance entre les numéros de pièces et les numéros de planches ainsi que les quantités de pièces par véhicule dans la planche considérée, sauf pour les numéros de boulonnerie normalisée. Le document P. R. 830 donne la signification des numéros codifiés de la boulonnerie normalisée.

UTILISATION

Détermination du numéro d'une pièce connaissant la nature de celle-ci:

1. Rechercher dans le **répertoire des planches** la planche correspondant à l'organe ou l'élément d'organe auquel cette pièce peut se rattacher.
2. Consulter la catalogue pour y retrouver cette planche en tenant compte éventuellement, du point de départ ou de la variante caractérisant la planche.
3. La planche étant déterminée, rechercher l'illustration de la pièce désirée.

A cette illustration correspond un ou plusieurs numéros. Choisir celui qui convient, compte tenu des signes ou expressions codifiés les caractérisant.

Les renvois numériques ou alphabétiques affectés aux numéros de pièces, assurent la liaison entre ces numéros et les renseignements complémentaires s'y rapportant, contenus dans les tableaux situés soit en bas de l'illustration soit en page annexe.

Vérification, par les Succursales Concessionnaires ou Centres Importateurs, d'un bon de commande, rédigé par un Agent ou un client ayant utilisé la documentation en sa possession.

1. Rechercher dans le **répertoire numérique**, au numéro de pièce donné par le bon de commande, les numéros de planches correspondantes.
2. Consulter ces planches pour vérifier si le numéro de pièce est bien celui qui convient compte tenu des points de départ affectés à ce numéro et du numéro de véhicule ou d'organe pour lequel la pièce est commandée.

Identification par l'illustration d'une pièce dont on connaît le numéro.

1. Rechercher dans le **répertoire numérique**, au numéro de pièce donné, le numéro des planches correspondantes.
2. Consulter ces planches.

CONDITIONS GÉNÉRALES DE VENTE

Voir les tarifs de pièces de rechange

INDLEDNING

Nærværende katalog indeholder alle enheder samt alle monterede originale løselede, som er salgbare ved udskiftning; det er med lethed muligt at identificere delene ved hjælp af illustrationerne. Disse samlede enheder og løselede er fordelt på **plancher**, idet de er vist i forbindelse med vogndelen eller enheden, hvorpå de skal monteres.

Hver **planche** er mærket med et nummer bestående af 4 tal, hvoraf de to første svarer til et kodetal på en bestemt vognedel; hvor flere plancher er identiske er disse yderligere tilføjet bemærkning med angivelse af afvigelse eller bergrænsninger af delenes anvendelse.

En planche består af: illustration af forskellige dele og sæt; til hver del svarer et eller flere numre, som man skelner ved en afvigelse eller et kodetegn.

og eventuelt **tabeller**, som indeholder oplysninger om bergrænsninger af delenes anvendelse, samt over forskellige dimensioner o. l.. Disse tabeller står enten forneden på illustrationen eller på en tillægsside.

Bemærkning: Forklaring på kodetegn og kodeudtryk, som bruges på plancherne, er opgivet på planche no. 05.

En **nummerfortegnelse** sidst i kataloget viser, hvorledes delnumre og planchenumre svarer til hinanden og viser også delantal pr. vogn på den pågældende planche, undtagen for de normale bolte, skruer og møtrikker. I katalog P. R. 830 findes kode-numrene for normale bolte, skruer og møtrikker.

ANVENDELSE

Fastsættelse af nummeret på en del man kender:

1. Find i registeret over **plancher** den planche, som svarer til den vognedel eller enhed på hvilken reservedelen er beregnet til at blive monteret.
 2. Slå op i kataloget og find denne planche, idet De holder Dem til eventuelle afvigelser og kodetegn der måtte stå på planchen.
 3. Når den rigtige planche er fundet, find da billedet af den ønskede del; til dette billede svarer et eller flere numre; vælg det, der passer i henhold til kodetegn eller kodeudtryk.
- De med tal eller bogstaver mærkede henvisninger ved delnummeret gør det muligt at finde forbindelsen mellem disse numre og de yderligere oplysninger der findes enten nederst på planchen eller på tillægssiden.

Ordresedler, der udstedes af en agent eller en kunde ved hjælp af vedlagte reservedelskatalog, skal kontrolleres af den koncessionerede forhandler eller af importøren.

1. Find i registeret over reservedelsnumre **nummeret på den planche**, som reservedelsnummeret henviser til.
2. Se på plancherne for at afgøre om det er de rigtige numre, idet De holder Dem til eventuelle afvigelser og kodetegn samt vognnummeret, som delene er bestilt til.

Fastsættelse ved hjælp af illustration af en del, hvis nummer man kender.

1. Find i registeret over reservedelsnumre **nummeret på den planche**, som reservedelsnummeret henviser til.
2. Slå op på planchen.

ALMINDELIGE SALGSBETINGELSER

Se reservedels-prislisten

VORWORT

Die vorliegende Ausgabe enthält alle montierten Einzelteile, die als Ersatzteile verkäuflich sind. Sie ermöglicht es, die Nummern mit Genauigkeit zu bestimmen und sie anhand der Abbildungen zu identifizieren.

Diese Aggregate und Teile sind in **Bildtafeln** aufgeteilt, und zwar ihrer Zugehörigkeit entsprechend.

Jede **Bildtafel** ist mit einer vierstelligen Nummer versehen, wovon die ersten zwei Ziffern einem bestimmten Organ-Schlüssel entsprechen; sie kann durch eine Variante oder einen Ausgangspunkt der Ersatzteilnummer gekennzeichnet sein, wenn sie mit einer gleichartigen Bildtafel übereinstimmt.

Eine Bildtafel besteht aus:

den Abbildungen der Aggregate und Teile, die in der Form voneinander abweichen; jedem dargestellten Teil entsprechen eine oder mehrere Teilnummern, untereinander gekennzeichnet durch eine Variante oder ein verschlüsseltes Zeichen.

Besonderen **Tabellen** mit zusätzlichen Angaben, wie z.B. Ausgangspunkt einer Ersatzteilnummer, oder Hinweisen (für die verschiedenen Ausführungen bzw. Änderungen).

Anmerkung: Die Erklärung der Zeichen und verschlüsselten Ausdrücke, die auf den Bildtafeln erscheinen, ist auf Seite 05, zu ersehen.

Am Ende des Kataloges finden Sie ein numerisches Sachverzeichnis, aus dem folgendes zu ersehen ist: die Ersatzteilnummer, die dazugehörige Bildtafelnummer und die Anzahl gleicher Teile pro Fahrzeug auf der Tafel. Ausgenommen sind die Nummern der genormten Schraubenwaren, die dem Katalog P. R. 830 zu entnehmen sind.

GEBRAUCHSANWEISUNG

Bestimmung der Nummer eines Teiles, dessen Beschaffenheit bekannt ist:

1. Im **Bildtafelverzeichnis** die Nummer der Bildtafel suchen, zu der das Teil oder Aggregat gehört.
2. Im Katalog diese Bildtafel nachschlagen und gegebenenfalls die Variante oder den Ausgangspunkt, die die Bildtafel kennzeichnen, berücksichtigen.
3. Für das Teil ist — auf der Bildtafel — eine oder mehrere Nummern angegeben. Bei der Wahl der richtigen Nummer sind eventuelle verschlüsselte Zeichen und Ausdrücke zu berücksichtigen. Anstelle der Ersatzteilnummer erscheint sehr oft eine einzelne Zahl. Dieselbe wird unten auf der Bildtafel wiederholt und weist auf zusätzliche Angaben hin.

Prüfen eines Bestellscheines, den ein Unterhändler oder Kunde mit der ihm zur Verfügung stehender Fachliteratur (Kataloge usw.) ausgestellt hat.

1. Im **numerischen Sachregister** unter der auf dem Bestellschein angegebenen Teilnummer die entsprechende Bildtafel suchen.
2. Die Bildtafel aufschlagen und prüfen, ob die angegebene Nummer richtig ist. Daher müssen die vorher schon genannten besonderen Hinweise beachtet werden.

Identifizierung eines Teiles, dessen Nummer bekannt ist, anhand der Abbildung:

1. Im numerischen Sachregister unter der bekannten Teilnummer die Nummer der entsprechenden Bildtafel herausuchen.
2. Diese Bildtafel zu Rate ziehen.

ALLGEMEINE VERKAUFSBEDINGUNGEN

Siehe Ersatzteil-Preisliste

INTRODUCTION

This document contains all the assemblies and parts sold as spares; it enables one to determine with precision their numbers and to identify them easily by the illustrations.

These assemblies and these parts are set out in illustrated plates according to the unit or sub-assembly to which they belong. Each plate is identified by a four figure number, the first two of which correspond to a specified unit code; it may be distinguished by a variant or a starting point in the case where it is identifiable with a similar plate.

A plate consists of:

the illustration of parts and assemblies contained in the plate and which differ in shape; to each part shown corresponds one or several part numbers distinguished one from the other by a variant or a code sign.

and when necessary, tables showing additional information such as starting point, and instructions. These tables figure either at the bottom of the illustration or on a page added to the illustration.

Note: The meaning of the code signs and expressions used on each plate, is indicated on plate n° 05.

A numerical index at the end of the catalogue gives the relationship between the part numbers and the plate numbers, also the quantity of parts per vehicle in the plate under consideration, except for the numbers of standard nuts and bolts. Document P. R. 830 gives the meaning of the code numbers of standard nuts and bolts.

USE

Ascertaining a part Number knowing the nature of this part:

1. In the plate index, find the plate corresponding to the unit or sub-assembly to which this part may be attached.

2. Consult the catalogue to find this plate, when necessary taking into account the starting point or the variant distinguishing this plate.

3. Having found the plate, look for the illustration of the desired part. One or several numbers correspond to this illustration; choose the suitable number, taking into account code signs or expressions which distinguish them.

The numerical or alphabetical reference marks added to the part number, ensure the connection between these numbers and the additional information appertaining to them, included in the tables found at the bottom of the illustration or on the additional page.

Checking by Branches, Distributors or Importation Centres of an Order Form which has been filled in by an Agent or by a client using the documents in his possession.

1. In the numerical index, at the part number indicated on the order form, find the corresponding plate numbers.

2. Examine these plates to check that the part number given is correct taking into account the starting points added to this number and the number of the vehicle or unit for which the part has been ordered.

Identifying by the illustration a part the number of which is known.

1. In the numerical index, at the given part number find the corresponding plate numbers.

2. Consult these plates.

GENERAL SALES CONDITIONS

See the spare parts price lists

INTRODUCCION

Este documento contiene todos los conjuntos y las piezas sueltas vendidas como repuestos; con él, los números se hallan con precisión y por medio de las láminas se les puede identificar con toda facilidad.

Estos conjuntos y piezas van repartidos por láminas, según el órgano o el elemento de órgano al que pertenecen.

Todas las láminas llevan un número de cuatro cifras, las dos primeras de las cuales corresponden a la anotación codificada del órgano; cuando la lámina pueda confundirse con otra similar, lleva especificada la variante en cuestión o el número del punto de partida.

Una lámina consta:

de la ilustración de las piezas y conjuntos contenidos en ella y que difieren de forma; cada una de las piezas ilustradas lleva uno o varios números de piezas, caracterizados entre sí por una variante o un signo convencional, y,

a veces, de cuadros donde figuran informes complementarios, tales como los puntos de partida, y las consignas. Estos cuadros se encuentran en una hoja anexa a la ilustración o en la parte inferior de la lámina.

Observación: El significado de los signos y expresiones convencionales empleados en las láminas figura en la lámina 05.

La lista numérica, inserta al final del Catálogo, da la correspondencia entre los números de las piezas y los de las láminas y las cantidades de piezas por vehículo que hay en la lámina considerada, excepto para los números de la tornillería normalizada, cuya interpretación se halla explicada en el documento P. R. 830.

MODO DE EMPLEO

Determinación del número de una pieza, conociendo la naturaleza de la misma:

1. Buscar en la lista de láminas, la lámina correspondiente al órgano o al elemento de órgano al que la pieza puede pertenecer.

2. Consultar el Catálogo y buscar la lámina, teniendo en cuenta en caso preciso, el punto de partida o la variante característica de la lámina.

3. Una vez encontrada la lámina, buscar la ilustración de la pieza deseada. A esta ilustración corresponde uno o varios números; elegir entre ellos el que conviene, habida cuenta de los signos o expresiones convencionales que le acompañan.

Las citas numéricas o alfabéticas que acompañan al número de pieza sirven para unirlos a los informes complementarios que le conciernen; estos informes se hallan en la parte inferior de la página o en hoja anexa (cuadros).

Verificación por las Sucursales, Concesionarios o los Centros Importadores, de un vale de pedido, redactado por un agente o un cliente, a base de la documentación que posee.

1. Buscar en la lista numérica, en el número de pieza señalado por el pedido, los números de las láminas correspondientes.

2. Consultar las láminas para comprobar si el número de la pieza es el que conviene, habida cuenta de los puntos de partida correspondientes a ese número y del número del vehículo o del órgano para el que se pide la pieza.

Identificación por la ilustración de una pieza cuyo número se conoce.

1. Buscar en la lista numérica, en el número de pieza dado, el número de las láminas correspondientes.

2. Consultar estas láminas.

CONDICIONES GENERALES DE VENTA

Véanse las tarifas de las piezas de recambio

PREMESSA

La presente raccolta contiene tutti i gruppi e i pezzi staccati, venduti come ricambi; permette di determinare con precisione i loro numeri e di identificarli facilmente per mezzo delle illustrazioni. Questi gruppi e questi pezzi sono ripartiti per Tavole secondo l'organo o l'elemento di organo ai quali si riferiscono.

Ogni Tavola è identificata da un numero a 4 cifre delle quali le prime due corrispondono ad un determinato codice degli organi; può essere caratterizzata da una variante od un punto di partenza nel caso in cui essa si identifichi con una tavola simile.

Una tavola si compone:

dell'illustrazione dei pezzi e gruppi contenuti nella tavola e che sono di forme differenti; ad ogni pezzo illustrato corrisponde uno o più numeri di pezzo caratterizzati fra essi da una variante o da un segno codificato.

ed eventualmente, da Tabelle che comportano delle informazioni complementari come il punto di partenza e istruzioni particolari. Queste tabelle figurano sia sotto l'illustrazione, sia su una pagina allegata all'illustrazione.

Osservazione: il significato dei segni ed espressioni codificate impiegate in ogni tavola è indicato nella tavola n° 05.

Un indice numerico, alla fine del catalogo, fornisce la corrispondenza fra i numeri dei pezzi ed i numeri delle tavole come pure le quantità di pezzi per veicolo nella tavola considerata, eccetto per i numeri di bulloneria normalizzata. Il documento P. R. 830 fornisce il significato dei numeri codificati della bulloneria normalizzata.

USO DEL CATALOGO

Determinazione del numero di un pezzo conoscendo la sua natura:

1. Cercare nell'indice delle tavole, la tavola corrispondente all'organo o all'elemento di organo al quale questo pezzo può riferirsi.

2. Consultare il Catalogo per trovare questa tavola tenendo conto eventualmente, del punto di partenza o della variante che caratterizza la tavola.

3. Determinata la tavola, cercare l'illustrazione del pezzo desiderato. A questa illustrazione corrispondono uno o più numeri; scegliere quello che conviene, tenendo conto dei segni od espressioni codificate che li caratterizzano. I rinvii numerici od alfabetici in corrispondenza del numero del pezzo, assicurano il collegamento fra questi numeri e le informazioni complementari che vi si riferiscono, contenuti nelle tabelle situate sia in calce all'illustrazione, sia nella pagina allegata.

Verifica, dalle Succursali, Concessionari o Centri Importatori, di un buono di ordinazione, redatto da un Agente o da un cliente che avrebbe usato la documentazione in suo possesso.

1. Cercare nell'indice numerico, al numero di pezzo dato dal buono di ordinazione, i numeri delle tavole corrispondenti.

2. Consultare queste tavole per controllare se il numero del pezzo è quello che corrisponde tenendo conto dei punti di partenza attribuiti a questo numero e del numero del veicolo o dell'organo per il quale il pezzo è stato ordinato.

Identificazione per mezzo dell'illustrazione di un pezzo del quale si conosce il numero.

1. Cercare nell'indice numerico, al numero di pezzo dato, il numero delle tavole corrispondenti.

2. Consultare queste tavole.

CONDIZIONI GENERALI DI VENDITA

Vedi tariffa pezzi di ricambio

INLEIDING

In deze catalogus zijn alle onderdeelgroepen en afzonderlijke onderdelen vermeld welke voor reparatiedoeleinden worden verkocht. De onderdelen zijn met de juiste nummers aangeduid en kunnen aan de hand van de afbeeldingen gemakkelijk worden geïdentificeerd.

De onderdeelgroepen en afzonderlijke onderdelen zijn in elke plaat gegroepeerd volgens het orgaan of deel van het orgaan waartoe zij behoren.

Iedere plaat is aangeduid met een nummer van vier cijfers, waarvan de eerste twee cijfers corresponderen met een code voor het betreffende orgaan. Hiervan kan zijn afgeweken in geval de aanduiding betrekking heeft op een overeenkomstige plaat.

Een plaat bestaat uit :

de afbeelding van de onderdelen en onderdeelgroepen welke in de plaat zijn opgenomen en welke in vorm verschillen ; met elk afgebeeld onderdeel correspondeert een nummer of meerdere nummers welke onderling gekenmerkt zijn door een afzonderlijke variërende aanduiding of een code-merkteken.

en eventueel uit een tabel waarin aanvullende gegevens zijn vermeld, zoals begin van uitgave en verdere aanduidingen. Deze tabellen zijn geplaatst, hetzij onderaan de afbeelding, hetzij op de bladzijde naast de afbeelding.

Opmerkingen : De verklaring van de betekenis van de in elke lijst gebruikte aanduidingen en code-merken is in de lijst no. 05, opgenomen.

Achterin de catalogus is een nummerieke inhoudsopgave opgenomen, waarin de onderdeelnummers en de daarmee corresponderende nummers van de betreffende platen zijn vermeld, evenals het aantal onderdelen per wagen, met uitzondering van het aantal genormaliseerde bouten. In het document P. R. 830 is de betekenis van de codenummers van de genormaliseerde bouten opgenomen.

GEbruIKSAANWIJZING

Bepalen van het onderdeelnummer wanneer de soort van het onderdeel bekend is

1. Zoek in de inhoudsopgave de plaat welke betrekking heeft op het orgaan waarvan het betreffende onderdeel deel uitmaakt.
2. Zoek in de catalogus deze plaat op, rekening houdend met eventueel afwijkende gegevens, zoals begin van uitgave en afwijkende aanduiding welke de plaat kenmerken.
3. Wanneer de plaat gevonden is, zoekt men daarin de afbeelding van het gewenste onderdeel op. Bij deze afbeelding staan één of meer nummers ; kies hieruit het juiste nummer, rekening houdend met de kenmerkende codemerkttekens of aanduidingen. De aanduidingen in cijfers of letters bij het onderdeelnummer verwijzen naar de aanvullende nummers en aanwijzingen (indien van toepassing), welke zijn vermeld in de tabellen onder de plaat of op de tegenoverliggende bladzijde.

Controle door de filialen, agenten of importeurs van een bestelbon, opgesteld door een subagent of een client, die gebruik heeft gemaakt van de in zijn bezit zijnde documentatie.

1. Zoek in de nummerieke inhoudsopgave aan de hand van het in de bestelbon gegeven onderdeelnummer de betreffende plaatnummers op.
2. Raadpleeg de platen om te controleren of het opgegeven onderdeelnummer wel het juiste is, rekening houdend met begin van uitgave van het nummer en het wagennummer of nummer van het orgaan waarvoor het onderdeel wordt besteld.

Identificatie van een onderdeel aan de hand van de afbeelding, wanneer het onderdeelnummer bekend is.

1. Zoek het nummer van de betreffende platen aan de hand van het juiste onderdeelnummer in de nummerieke inhoudsopgave.
2. Raadpleeg de platen.

ALGEMENE VERKOOPSVORWAARDEN

Zie de onderdelentarievenlijsten

INLEDNING

Föreliggande katalog innehåller en förteckning över reservdelar och kompletta enheter, som kan monteras vid reparation. Den gör det möjligt att exakt fastställa delarnas nummer och att identifiera dem med ledning av illustrationerna.

Varje detalj och varje enhet kan återfinnas på en bild, föreställande den huvudenhet i vilken detaljen ingår.

Varje planschsida har ett 4-siffrigt nummer av vilket de två första siffrorna motsvarar en kodbeteckning för huvudenheten eller organet ifråga ; avbildningen kan ha en variant eller en konstruktionsändring med utgång från ett visst fabriktionsnummer och i sådant fall finnes två likartade planscher.

En plansch består av :

Avbildning av delarna och den enhet i vilken dessa ingår ; till varje avbildad detalj svarar ett eller flera reservdelsnummer som sinsemellan karakteriseras genom en variant eller en kodbeteckning.

Eventuellt av en tablå, som ger kompletterande upplysningar såsom från vilket fabriktionsnummer en viss detalj monteras och vilka delar, som erfordras vid utbyte. Dessa tablåer återfinnes antingen längst ned på planschen eller på ett blad intill planschen.

Anmärkning : Förklaring till de märken och kodbeteckningar, som finnes på varje plansch, återfinnes på plansch nr. 05.

I slutet av katalogen finnes en referenslista mellan reservdelsnummer och planschnummer såväl som uppgift på det antal, som åtgår av varje detalj, (med undantag för numren på bultar av standardtyp).

ANVÄNDNING

Fastställande av numret på en viss reservdel tillgås på följande sätt :

1. Sök i bildregistret upp den bild som omfattar den huvudenhet i vilken den aktuella delen ingår eller med vilken den sammanhänger.
 2. Sök upp denna plansch i katalogen och tag därvid hänsyn till eventuellt förekommande variant- eller fabriktionsnummer.
 3. Då den önskade planschen återfunnits skall den eftersökta delen uppsökas. Till den avbildade delen finnes ett eller flera reservdelsnummer och man skall välja det nummer, som motsvarar de märken eller kodbeteckningar som betecknar den del man vill ha.
- De siffror eller bokstäver som i:n förekomma framför eller efter ett reservdelsnummer hänvisar till kompletterande upplysningar om detaljen och återfinnes i en tablå längst ned på sidan eller på vidstående sida.

Filialers och centralimportörers kontroll av beställningssedel, som utskrivits av en representant eller en kund med ledning av tillgänglig dokumentation.

1. Leta i nummerregistret med ledning av det reservdelsnummer som framgår av beställningssedeln, reda på numret på motsvarande bild.
2. Kontrollera med ledning av planschen att det uppgivna reservdelsnumret är det riktiga med hänsyn till det uppgivna fabriktionsnumret.

Identifiering med ledning av en bild av en detalj vars nummerbeteckning är känd :

1. Sök med ledning av nummerregistret upp numret på den bild som upptar den aktuella detaljen.
2. Slå upp denna bild.

ALLMÄNNA FÖRSALJNINGSVILLKOR

Se Reservdelsprislista

**05.01**

A

P.R. 810

05.01

A

P.R. 810



	FRANÇAIS	DEUTSCH	ESPAÑOL	NEDERLANDS
	ENGLISH	DANSK	ITALIANO	SVENSKA
†	Pièce à épuiser Use up stock	Auslaufende Teile. Dele til at opbruge	Pieza que hay que agotar. Pezzo da esaurire.	Onderdeel komt te vervallen, levering zolang de voorraad strekt. Utförsäljes.
⊕	Après épuisement, prévoir After exhaustion of stock, supply	Nach Auslaufen vorsehen. Efter udgået lager bestil	Una vez agotada, prever. Dopo esaurimento prevedere.	Te gebruiken nadat de bestaande voorraad is uitgeput. Efter utförsäljning levereras.
👁️	Voir planche ou voir page. "See plate" or "see page"	Siehe Bildtafel oder Seite. Se planche eller se side	Ver lamina o ver página. Vedere tavola o vedere pagina.	Zie afbeelding of blz. Se plansch eller sida.
↘	Pour For	Für Til	Para Per	Voor För.
↗	Sauf Except.	Ausser Uden	Excepto. Eccetto.	Uitgezonderd. Utom.
👉	Direction à gauche. 👁️ 05.40 L. H. drive. 👁️ 05.40	Links-Lenkung. 👁️ 05.40 Venstrestyret. 👁️ 05.40	Dirección a la izquierda. 👁️ 05.40 Guida a sinistra. 👁️ 05.40	Links stuur. 👁️ 05.40 Vänsterstyrd. 👁️ 05.40
👈	Direction à droite. 👁️ 05.40 R. H. drive. 👁️ 05.40	Rechts-Lenkung. 👁️ 05.40 Højrestyret. 👁️ 05.40	Dirección a la derecha. 👁️ 05.40 Guida a destra. 👁️ 05.40	Rechts stuur. 👁️ 05.40 Högerstyrd. 👁️ 05.40
☐	Équipement facultatif. Optional equipment.	Ausrüstung nach Wunsch. Valgfrit udstyr.	Equipo opcional. Equipaggiamento facoltativo.	Behoort niet tot de standaard-uitrusting. Valfri utrustning.
➡	à to	bis til	a a	tot till
⌘	et And.	Und. og.	y e	en. Och.

**05.02**

A

P.R. 810

05.02

A

P.R. 810



	Pièces à prévoir en supplément. Supplementary parts to be foreseen.	Teile zusätzlich vorzusehen. Bestilling af ekstradele.	Piezas suplementarias. Pezzi da prevedere in supplemento.	Aanvullend in voorraad te nemen onderdelen. Supplementdelar.
	Consignes d'interchangeabilité. Interchangeability instructions symbolised by.	Anweisungen für die Auswechslung, symbolisiert durch. Når udskifning tilrådes, bruges følgende tegn.	Consignas de intercambiabilidad, simbolizadas por. Istruzioni per l'intercambiabilità simbolizzati da.	Aanwijzingen betreffende verwisselbaarheid, aangeduid door. Anvisningar för utbyte.
	Numéros de véhicules ou d'organes. Numbers of vehicles or units in question symbolised by.	Nummern der betreffenden Fahrzeuge oder Organe symbolisiert durch. Det pågældende vognummer eller aggregatnummer med.	Números de vehículos o de órganos interesados, simbolizados por. Numeri dei veicoli o degli organi interessati simbolizzati da.	Serienummer van de betreffende wagens of organen aangeduid door. Vagn eller organ tillverkningsnummer.
	Son aigu. High pitch.	Hohe Tonlage. Sjarp tone.	Sonido agudo. Suono acuto.	Hoge toon. Högton.
	Son grave. Low pitch.	Tiefe Tonlage. Merk tone.	Sonido grave. Suono grave.	Lage toon. Lågton.
	Nombre de dents. Number of teeth.	Anzahl der Zähne. Tandantal.	Número de dientes. Numero di denti.	Aantal tanden. Antal kuggar.
	Unité de vente. Sold in following quantities.	Verkaufseinheit. Salgsenhed.	Unidad de venta. Unità di vendita.	Verkoopseenheid. Försäljningslängd.
	Vente en longueur de fabrication. Sold in manufactured length.	Verkauf nach Fabrikationslängen. Salg efter fabrikationslængde.	Venta a la longitud de fabricación. Vendita in lunghezza di fabbricazione.	Verkoop in fabricagelengte. Försäljning per tillverkningslängd.
	Admission. Inlet.	Einlass. Indsugning.	Admisión. Aspirazione.	Inlaat. Insugning.
	Échappement. Exhaust.	Auspuff. Udblæsning.	Escape. Scarico.	Uitlaat. Avgassystem.
	Conditions spéciales d'échange. Special conditions for replacement.	Spezial-Austauschbedingungen.	Condiciones generales de cambio. Speciali condizioni per la sostituzione.	Speciale ruil condities. Villkor för speciell utbytesservice.

**05.03**

A P.R. 810

05.03

A P.R. 810



	Ou bien. Or.	Oder. Eller.	O bien. Oppure.	Of wel. Eller.
	Pièces vendues en collection sous un seul numéro. Parts sold as a kit under one part number	Unter einer einzigen Nummer als Satz verkaufte Teile	Piezas vendidas por colecciones bajo un solo número Parti vendute in serie con un'unico numero	Onderdelen, die als set onder één nummer verkocht worden.
	Emplacement du marquage sur l'ensemble ou la pièce. Position of the marking on the assembly or the part.	Lage der Markierung am Teil oder an der Baugruppe. Placering af mærkningerne på enheden eller delen.	Emplazamiento de la marca en el conjunto o en la pieza. Spazio riservato al contrassegno di riferimento sul complessivo o sulla parte.	Plaats van het typeplaatje van de groep of het onderdeel. Plats för typskylt.
1	1 ^{re} vitesse. 1st speed.	1. Gang. 1. gear.	1 ^a velocidad. 1a velocità.	1e versnelling. 1:an.
2	2 ^e vitesse. 2nd speed.	2. Gang. 2. gear.	2 ^a velocidad. 2a velocità.	2e versnelling. 2:an.
3	3 ^e vitesse. 3rd speed.	3. Gang. 3. gear.	3 ^a velocidad. 3a velocità.	3e versnelling. 3:an.
4	4 ^e vitesse. 4th speed.	4. Gang. 4. gear.	4 ^a velocidad. 4a velocità.	4e versnelling. 4:an.
1-2	1 ^{re} et 2 ^e vitesses. 1st and 2nd speeds.	1. und 2. Gang. 1. og 2. gear.	1 ^a y 2 ^a velocidades. 1a e 2a velocità.	1e en 2e versnelling. 1:an och 2:an.
3-4	3 ^e et 4 ^e vitesses. 3rd and 4th speeds.	3. und 4. Gang. 3. og 4. gear.	3 ^a y 4 ^a velocidades. 3a e 4a velocità.	3e en 4e versnelling. 3:an och 4:an.
R	Marche arrière. Reverse.	Rückwärtsgang. Bak-gear.	Marcha atrás. Retro marcia.	Achteruit. Back.

**05.04**

A P.R. 810

05.04

A P.R. 810

**0**

Couleur, voir page 100.01.

Farbe siehe Seite 100.01.

Color ver la página 100.01.

Kleur zie pagina 100.01.

For colour see page 100.01.

Vedr. farve, se side 100.01.

Per la tinta vedere a pagina 100.01.

Färg se sid 100.01.

7

Sellerie Simili.

Kunstleder-bezug

Tapizado simili-cuero

Kunstleren beklædning

Leathercloth upholstery

Indtræk af kunstlæder

Rivestimento similpelle

Inredning av konstläder

11

Feutre.

Filz.

Fieltro.

Vilt.

Felt.

Filt.

Feltro.

Filt.

12

Toile à bâche.

Planenstoff.

Lona para toldo.

Zeildoek voor huif.

Tilt canvas.

Presenning

Tessuto per tendone.

Presenningsväv.

.../000

Numéro d'équipement.

Ausrüstungsnummer.

Número de su equipo.

Uitrustingsnummer.

Equipment version number.

Udstyrsnummer.

Numero di equipaggiamento.

Utrustningsnummer.



Plateau cabine tolée tous types

Pritsche mit geschlossener kabine

Plataforma con toldo cabina rígida.

Vrachtauto met gesloten cabine, alle typen

Metal cab floor - all types

Cassone cabanito in lamiera tutti i tipi



Plateau nu

Pritschenwagen

Plataforma desnuda.

Platte laadbak.

Platform only.

Pick-up.

Piattaforma nuda.

Pick-up.



Plateau à ridelles.

Pritsche mit Spriegeln.

Plataforma con barandillas.

Open laadbak met zijschotten.

Hinged sided platform

Pick-up.

Piattaforma con fiancate ribaltabili.

Flak med læmmer



Plateau bâché cabine tólée

Pritsche mit Plane, Fahrerhaus geschlossen.

Plataforma con barandas y toldo.

Open laadbak met zijschotten en huif.

Tarpaulin covered platform, metal cab.

Pick-up med presenning.

Autotelaio con centine e tendone.

Pick up med presenning.



Fourgon à pavillon surélevé

Kastenwagen mit überhöhtem Dach

Furgón con el techo superalto.

Bestelwagen met verhoogd dak.

High roof van.

Kassevogn med forhøjet tag

Furgone a padiglione sopraelevato.

Skåp, forhøjt tak.

**05.05**

A P.R. 810

05.05

A P.R. 810

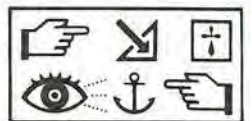

Ah	Ampère-heure.	Amperestunde.	Amperio-Hora.	Ampere-uur.
	Amp/hour.	Amperetimer.	Ampere-ora.	Ampere-timmar.
BP	Boîte-pont.	Getriebe-Differential.	Caja-puente.	Versnellingsbak-differentieel.
	Gearbox-differential.	Gearkasse-Differentiale.	Gruppo cambio-differenziale.	Växellåda - bakaxel.
MOT	Moteur.	Motor.	Motor.	Motor.
	Engine.	Motor.	Motore.	Motor.
TAR	Train arriere.	Hinterachse.	Tren trasero.	Achtertrein.
	Rear axle assembly.	Bagtøj.	Treno posteriore.	Bakvagn.
TAV	Train avant.	Vorderachse.	Tren delantero.	Voortrein.
	Front axle assembly.	Fortøj.	Avantreno.	Framvagn.
V	Volts.	Volt.	Voltio.	Volt.
	Volts.	Volt.	Volt.	Volt.
VEH	Véhicule.	Fahrzeug.	Vehículo.	Wagen.
	Vehicle.	Vogn.	Veicolo.	Vagn.
W	Watt.	Watt.	Vatio.	Watt.
	Watt.	Watt.	Watt.	Watt.
	Les poids et mesures sont indiqués en système métrique.	Gewichte und Längenmasse sind nach dem Dezimalsystem aufgeführt.	Los pesos y medidas se indican en el sistema métrico.	Maten en gewichten zijn in metrische waarden opgegeven.
	Weights and measures are in metric units.	Vægt og mål er anført efter det metriske system.	I pesi e le misure sono indicati secondo il sistema metrico.	Vikt och längd enligt decimal- och meter-system.
	Les cotes non suivies de symbole sont en millimètres.	Masse ohne Einheitsangabe sind in Millimetern ausgedrückt.	Las cotas no seguidas de símbolo indican milímetros.	De maten waar geen teken achter staat zijn in millimeters.
	Those dimension which have no following symbol are in millimetres.	Mål uden signaturforklaring er mm.	Le quote non seguite dal simbolo sono in millimetri.	När beteckning saknas är längden angiven i millimeter.

☞ / 10/11/12/13/14/15/18/20/21/22/24/26/27/28/29/30/40/41/42/100/101/102/103
120/121/122/130/140/200/201/202/203/204/207/211/220/230/231/240/241/242

☞ / 70/80/81/84/86/88/89/700/800/801/803/807/810/811

- R 2134
1 R 2135 VEH n° 1 ⇨ VEH n° 2101
- R 2134
2 R 2135 VEH n° 2102 ⇨ VEH n° 5329
- R 2134
3 R 2135 VEH n° 5330 ⇨ VEH n° 7362
- R 2134
4 R 2135 VEH n° 7363 ⇨ VEH n°

Origine	Traduction Française	1	2	3	4
Açores		21	21	21	207
Aden		80	80	80	800
Afghanistan		28	28	28	211
Algérie (Rép.)		20	20	20	200
Andorra	Andorre	21	21	21	201
Angola		21	21	21	207
Antilles Néerlandaise	Antilles hol.	21	21	21	201
Arabia	Arabie	21	21	21	201
Argentine	Argentine				
Australie	Australie	80	80	80	800
Bahamas		80	80	80	800
Bahrein		22	22	22	204
		80	80	80	800
Barbade		80	80	80	800
Belgie	Belgique	11	11	11	101
Bermudes		80	80	80	800
Bolivie		26	26	26	203
Bornéo					
Brasil	Brésil	21	21	21	201
Bulgarie	Bulgarie	29	27	27	230
					220
Burundi					
Cabo Verde	Cap Vert (Iles)	21	21	21	207
Cambodge		20	20	20	200
Cameroun (Rép.)		20	20	20	200
Canada		41	41	41	240

Origine	Traduction Française	1	2	3	4
C.C.C.P.	U.R.S.S.	29	27	27	230
Centrafricaine (Rép.)		20	20	20	200
Ceskoslovensko	Tchécoslovaquie	29	27	27	230
Ceylan		80	80	80	800
Channel Islands	Iles anglo-normandes	70	70	70	700
Chile	Chili	21	21	21	201
China	Chine				
Colombia	Colombie	26	26	26	203
Comores					
Congo (Ex. Belge)		21	21	21	201
Congo (Rép.)		20	20	20	200
Costa Rica		21	21	21	201
Côte Franç. des Somalis		20	20	20	200
Côte-d'Ivoire (Rép.)		20	20	20	200
Cuba		28	28	28	211
Cyprus	Chypre	80	80	80	800
Dahomey (Rép.)		20	20	20	200
Danmark	Danemark	15	15	15	122
Deut. Bundesrepublik	Allemagne Fédérale	12	12	12	120
Deut. Demokr. Rép.	Rép. Démocrat. All.	18	18	18	130
Dominica (Republica)	Rép. Dominicaine	21	21	21	201
Eire	Rép. d'Irlande	70	70	70	700
Egypte		21	21	21	201
Ecuador	Equateur	26	26	26	203
El Salvador		21	21	21	201
España	Espagne	21	21	21	201

Origine	Traduction Française	1	2	3	4
Ethiopia	Ethiopie	26	26	26	203
France		10	10	10	100
Gabon (Rép.)		20	20	20	200
Gambia	Gambie	22	22	22	204
Gaza-Zône		21	21	21	201
Ghana		80	80	80	800
Gibraltar		21	21	21	201
		80	80	80	800
Great Britain	Grande-Bretagne	70	70	70	700
Guadeloupe		20	20	20	200
Guam					
Guatemala		26	26	26	203
Guiana	Guyane Britannique	80	80	80	800
Guinea Española	Guinée Espagnole	21	21	21	201
Guinea Portuguesa	Guinée Portugaise	21	21	21	207
Guinée (Rép.)		20	20	20	200
Guyane Française		20	20	20	200
Haïti		21	21	21	201
Haute-Volta (Rép.)		20	20	20	200
Hellas	Grèce	21	21	21	201
Honduras (Rép.)		26	26	26	203
Honduras Brit.					
Hong-Kong		80	80	80	800
Ile du Man					

Origine	Traduction Française	1	2	3	4
Iles Seychelles					
Ile vierge Brit.		80	80	80	800
India	Inde				
Indonésia	Indonésie	89	84	84	811
Irak		28	28	28	211
Iran		21	21	21	201
Island	Islande	41	41	41	240
		42	42	42	242
Islas Canarias	Iles Canaries	21	21	21	201
Israël		28	28	28	211
Italia	Italie	13	13	13	102
Jamaïca	Jamaïque	80	80	80	800
Japon		81	81	81	801
Jordanie		28	28	21	201
Jugoslavija	Yougoslavie	21	21	21	201
					220
Kenya		86	86	86	803
Koréa	Corée				
Koweït		21	21	21	201
Laos		20	20	20	200
Leeward Islands	Iles-sous-le-Vent	80	80	80	800
Liban		21	21	21	201
Libéria		22	22	22	204
Libye		21	21	21	201
Liechtenstein					

Origine	Traduction Française	1	2	3	4
Luxembourg		11	11	11	101
Madagascar (Rép.)		20	20	20	200
Madeira	Madères	21	21	21	207
Magyarszag	Hongrie	29	27	27	230
Malaya	Malaisie	80	80	80	800
Malawi		86	86	86	803
Mali (Rép.)		20	20	20	200
Malta	Malte	80	80	80	800
Maroc Roy.		20	20	20	200
Maroc Esp.		21	21	21	201
Martinique		20	20	20	200
Mauritanie (Rép.)		20	20	20	200
Mauritius	Iles Maurice	80	80	80	800
Mexique		26	26	26	203
Mozambique		81	81	81	807
Nederland	Hollande				
Nicaragua		21	21	21	201
Niger (Rép.)		20	20	20	200
Nigéria		80	80	80	800
Norge	Norvège	40	40	40	241
Nouvelle-Calédonie		20	20	20	200
Nouvelle-Guinée		80	80	80	800
Nouvelles-Hébrides		20	20	20	200
New Zealand	Nouvelle-Zélande	80	80	80	800
Österreich	Autriche	14	14	14	121

Origine	Traduction Française	1	2	3	4
Pakistan		88	88	88	810
Panama		21	21	21	201
Paraguay		21	21	21	201
Pays-Bas		11	11	11	101
					103
Peru	Pérou	26	26	26	203
Philippines		21	21	21	201
Polska	Pologne	29	27	27	231
Portugal		21	21	21	207
Porto-Rico					
Qatar		21	21	21	201
Réunion (La)		20	20	20	200
Rhodésie		86	86	86	803
Rômanie	Roumanie	21	21	21	220
Saint-Marin					
Saint-Pierre-et-Miquelon		41	41	41	240
São Tomé		21	21	21	207
Schweiz	Suisse	30	30	30	140
Sénégal		20	20	20	200
Shqiperija R.P.	Albanie	28	28	28	211
Sierra Léone		80	80	80	800
Somaliland	Somalie (Rép.)	24	24	24	202
South Africa (Rép.)	Afrique du Sud (Rép.)				800
South West Africa	S.-O. Africain	86	86	86	803
Sudan	Soudan	88	88	88	800

Origine	Traduction Française	1	2	3	4
Suomi	Finlande	40	40	40	241
Suriname	Guyane Hollandaise	21	21	21	201
		81	81	81	801
Sverige	Suède	42	42	42	242
					241
Syrie		21	21	21	201
Tahiti		20	20	20	200
Taiwan	Formose				201
Tanzania	Tanzanie	86	86	86	803
Tchad (Rép.)		20	20	20	200
Thaïlande		81	81	81	801
Togo (Rép.)		20	20	20	200
Trinidad	Trinité	80	80	80	800
Tunisie (Rép.)		20	20	20	200
Turkiye	Turquie	28	28	28	211
Uganda	Ouganda	86	86	86	803
Union of Burma	Birmanie	88	88	88	810
Uruguay		21	21	21	201
U.S.A.	Etats-Unis d'Amérique	86	86	86	
Vénézuela		21	21	21	201
Viet Nam Nord		20	20	20	200
Viet-Nam Sud		20	20	20	200
Windward Islands	Iles-du-Vent	80	80	80	800
Zambïa	Zambie	86	86	86	803

**06. 01**

A P.R. 810

06. 01

A P.R. 810



(21) MOT 688-01 n° 1 à MOT n° 83.762.

Pièces à prévoir en supplément :

06 08 331 902 - 2 -

06 08 349 302 - 2 -

10 81 301 080 - 2 -

Opération à effectuer :

Aléser à 10,5 mm les trous de la traverse avant de fixation du moteur.

(23) Cet allumeur est marqué de deux lettres et d'un chiffre.

Le marquage est frappé sur le carter de l'allumeur.

a) La première lettre signifie le mois :

A = Janvier G = Juillet

B = Février H = Août

C = Mars I = Septembre

D = Avril J = Octobre

E = Mai K = Novembre

F = Juin L = Décembre

b) Le chiffre indique l'année :

Ex. : 5 = 1965.

c) La deuxième lettre indique la modification du fournisseur :

B = I.S.O.

Ce marquage est à utiliser comme chiffre d'application.

(43) Jusqu'au véhicule n° 16 401, sauf n° 16 389 et 16 396.

L'adaptation d'une transmission "tripode" sur le côté droit du véhicule nécessite le montage de :

a) Pour équipements :

R 2134 / 10/11/15/18/20/21/22/24/26/27/28
29/41/100/101/103/122/130/200

R 2135 / 201/202/203/204/207/211/220/230
231/240 :

77 00 504 575 - 1 -

77 01 452 152 - 1 -

b) Pour équipements :

R 2134 / 12/13/14/30/40/42/70/80/81/84/86
88/89/102/120/121/140/241/242/700

R 2135 / 800/801/803/807/810/811

77 00 504 801 - 1 -

77 00 508 387 - 1 -

77 00 508 389 - 1 -

77 00 509 485 - 1 -

(55) Non monté en série.

(63) R 2134, R 2135.

L'adaptation de cette pièce nécessite le montage de :

- 77 00 525 876 - 1 - Catadioptré Droit

- 77 00 525 878 - 1 - Catadioptré Gauche

- 77 00 522 221 - 1 - Commutateur

- 77 00 523 489 - 1 - Entretoise

- 08 54 531 300 - 1 - Plaque raccord

- 77 01 980 645 - 1 - Cablage Arrière Gauche

- 77 01 980 646 - 1 - Cablage Arrière Droit

(64) R 2134 / 10/11/12/14/15/18/20/21/22/24/26/27
28/29/30/40/42/100/101/103/120/121
R 2135 / 122/130/140/200/201/202/203/204
207/211/220/230/231/241/242.

L'adaptation de cette pièce nécessite le montage de :

- 77 00 519 406 - 1 - Feu Avant Droit

- 77 00 519 407 - 1 - Feu Avant Gauche

- 77 00 519 412 - 2 - Lampe direction

- 08 55 620 800 - 2 - Lampe position

- 77 00 365 009 - 2 - Feu Arrière

- 77 00 526 413 - 2 - Lampe stop

- 77 00 526 412 - 2 - Lampe direction.

(65) R 2134 / 13/102
R 2135 /

L'adaptation de cette pièce nécessite le montage de :

- 77 00 522 301 - 1 - Feu Avant Droit

- 77 00 522 302 - 1 - Feu Avant Gauche

- 77 00 519 412 - 2 - Lampe direction

- 08 55 620 800 - 2 - Lampe position

- 77 00 365 009 - 2 - Feu Arrière

- 77 00 526 413 - 2 - Lampe stop

- 77 00 526 412 - 2 - Lampe direction

(66) R 2134 / 41/240
R 2135 /

L'adaptation de cette pièce nécessite le montage de :

- 77 00 519 406 - 1 - Feu Avant Droit

- 77 00 519 407 - 1 - Feu Avant Gauche

- 08 54 626 500 - 2 - Lampe direction

- 08 55 620 800 - 2 - Lampe position

- 77 01 365 010 - 2 - Feu Arrière

- 08 54 576 100 - 2 - Lampe stop

(67) R 2134 / 10/11/12/13/15/18/20/21/22/24/26
27/28/29/100/101/102/103/120/122
R 2135 / 130/200/201/202/203/204/207/211
220/230/231.

L'adaptation de cette pièce nécessite le montage de :

- 77 01 981 072 - 1 - Cablage Avant moteur

- 77 01 981 076 - 1 - Cablage châssis.

(68) R 2134 / 30/40/41/42/140/240/241/242
R 2135 /

L'adaptation de cette pièce nécessite le montage de :

- 77 01 981 081 - 1 - Cablage Avant moteur

- 77 01 981 076 - 1 - Cablage châssis

(69) R 2134 / 14/121
R 2135 /

L'adaptation de cette pièce nécessite le montage de :

- 77 01 981 072 - 1 - Cablage Avant moteur

- 77 01 981 080 - 1 - Cablage châssis.



(21) Type 688.01 engine Nos 1 to 83.762.

Supplementary parts to be foreseen :

- 06 08 331 902 - 2 -
- 06 08 349 302 - 2 -
- 10 81 301 080 - 2 -

Operation to be carried out :

Ream out the holes in the engine front mounting cross member to a diameter of 10.5 mm.

(23) This distributor is marked with two letters and a figure.

This is stamped on the distributor casing.

a) The letter indicates the month :

- A = January G = July
- B = February H = August
- C = March I = September
- D = April J = October
- E = May K = November
- F = June L = December

b) The figure indicates the year :

E : 5 = 1965.

c) The second letter indicates the supplier's modification :

B = I.S.O.

This marking is to be used as an introduction number.

(43) Up to and including vehicle No. 16.401, except No.s 16.389 and 16.396

The adaptation of a drive shaft with "spider" coupling to the right hand side of the vehicle requires the fitting of :

a) for versions

- R 2134 | 10/11/15/18/20/21/22/24/26/27/28
- R 2135 | 29/41/100/101/103/122/130/200/201
- | 202/203/204/207/211/220/230/231
- | 240

- 77 00 504 575 - 1 -
- 77 01 452 152 - 1 -

b) for versions

- R 2134 | 13/12/14/30/40/42/70/80/81/84/86
- R 2135 | 88/89/102/120/121/140/241/242
- | 700/800/801/803/807/810/811

- 77 00 504 801 - 1 -
- 77 00 508 387 - 1 -
- 77 00 508 389 - 1 -
- 77 00 509 485 - 1 -

(55) No fitted in production.

(63) R 2134, R 2135.

The adaptation of this part requires the fitting of :

- 77 00 525 876 - 1 - R.H. Catseye
- 77 00 525 878 - 1 - L.H. Catseye
- 77 00 522 221 - 1 - Commutator
- 77 00 523 489 - 1 - Spacer
- 08 54 531 300 - 1 - Junction Plate
- 77 01 980 645 - 1 - L.H. rear wiring harness
- 77 01 980 646 - 1 - R.H. rear wiring harness

(64) R 2134 | 10/11/12/14/15/18/20/21/22/24/26
 R 2135 | 27/28/29/30/40/42/100/101/103/120
 121/122/130/140/200/201/202/203
 204/207/211/220/230/231/241/242

The adaptation of this part requires the fitting of :

- 77 00 519 406 - 1 - R.H. front sidelight
- 77 00 519 407 - 1 - L.H. front sidelight
- 77 00 519 412 - 2 - Direction indicator bulb
- 08 55 620 800 - 2 - Sidelight bulb
- 77 00 365 009 - 2 - Rear light
- 77 00 526 413 - 2 - Stoplight bulb
- 77 00 526 412 - 2 - Direction indicator bulb

(65) R 2134 |
 R 2135 | 13/102

The adaptation of this part requires the fitting of :

- 77 00 522 301 - 1 - R.H. front sidelight
- 77 00 522 302 - 1 - L.H. front sidelight
- 77 00 519 412 - 2 - Direction indicator bulb
- 08 55 620 800 - 2 - Sidelight bulb
- 77 00 365 009 - 2 - Rear light
- 77 00 526 413 - 2 - Stoplight bulb
- 77 00 526 412 - 2 - Direction indicator bulb

(66) R 2134 |
 R 2135 | 41/240.

The adaptation of this part requires the fitting of :

- 77 00 519 406 - 1 - R.H. front sidelight
- 77 00 519 407 - 1 - L.H. front sidelight
- 08 54 626 500 - 2 - Direction indicator bulb
- 08 55 620 800 - 2 - Sidelight bulb
- 77 01 365 010 - 2 - Rear light
- 08 54 576 100 - 2 - Stoplight bulb

(67) R 2134 | 10/11/12/13/15/18/20/21/22/24/26
 R 2135 | 27/28/29/100/101/102/103/120/122
 130/200/201/202/203/204/207/211
 220/230/231.

The adaptation of this part requires the fitting of :

- 77 01 981 072 - 1 - Front engine wiring harness
- 77 01 981 076 - 1 - Chassis wiring harness

(68) R 2134 |
 R 2135 | 30/40/41/42/140/240/241/242.

The adaptation of this part requires the fitting of :

- 77 01 981 081 - 1 - Front engine wiring harness
- 77 01 981 076 - 1 - Chassis wiring harness.

(69) R 2134 |
 R 2135 | 14/121

The adaptation of this part requires the fitting of :

- 77 01 981 072 - 1 - Front engine wiring harness
- 77 01 981 080 - 1 - Chassis wiring harness.



06. 03

A P.R. 810

06. 03

A P.R. 810



(21) Motor 688.01 Nr 1 bis Nr 83.762.

Zusätzlich vorzuschende Teile :

06 08 331 902 - 2 -
06 08 349 302 - 2 -
10 81 301 080 - 2 -

Durchzuführende Arbeiten :

Die Bohrungen der vorderen Motortraverse auf 10,5 mm aufbohren.

(23) Dieser Zündverteiler ist durch zwei Buchstaben und eine Zahl gekennzeichnet, die auf dem Gehäuse eingestanzt sind

a) Der erste Buchstabe bezeichnet den Monat :

A = Januar G = Juli
B = Februar H = August
C = März I = September
D = April J = Oktober
E = Mai K = November
F = Juni L = Dezember

b) Die Zahl bestimmt das Jahr :
E. : 5 = 1965.

c) Der zweite Buchstabe entspricht der Variante :
B = I.S.O.

Diese Markierung ist als Anfangsnummer einer Änderung zu werten.

(43) Bis Fahrzeug-Fabrikations-Nr. 16.401, ausgenommen von Nr. 16.389 bis 16.396.

Die Montage einer Antriebswelle mit Kreuzgelenk "Tripode" auf der rechten Fahrzeugseite bedingt die Montage von :

a) Bei Ausrüstungs-Nr. :

R 2134 | 10/11/15/18/20/21/22/24/26/27/28
29/41/100/101/103/122/130/200
R 2135 | 201/202/203/204/207/211/220/230
231/240.

77 00 504 575 - 1 -
77 01 452 152 - 1 -

b) Bei Ausrüstungs-Nr. :

R 2134 | 12/13/14/30/40/42/70/80/81/84/86
88/89/102/120/121/140/241/242/700
R 2135 | 800/801/803/807/810/811.

77 00 504 801 - 1 -
77 00 508 387 - 1 -
77 00 508 389 - 1 -
77 00 509 485 - 1 -

(55) Keine Serienmontage.

(63) R 2134, R 2135.

Die Anbringung dieses Teiles bedingt die Montage von :

- 77 00 525 876 - 1 - Rückstrahler rechts
- 77 00 525 878 - 1 - Rückstrahler links
- 77 00 522 221 - 1 - Schalter
- 77 00 523 489 - 1 - Distanzhülse
- 08 54 531 300 - 1 - Klemmleiste
- 77 01 980 645 - 1 - Kabelstrang hinten links
- 77 01 980 646 - 1 - Kabelstrang hinten rechts

(64) R 2134 | 10/11/12/14/15/18/20/21/22/24/26
27/28/29/30/40/42/100/101/103/120
R 2135 | 121/122/130/140/200/201/202/203
204/207/211/220/230/231/241/242

Die Anbringung dieses Teiles bedingt die Montage von :

- 77 00 519 406 - 1 - Standlicht vorne rechts
- 77 00 519 407 - 1 - Standlicht vorne links
- 77 00 519 412 - 2 - Blinkleuchte
- 08 55 620 800 - 2 - Parkleuchte
- 77 00 365 009 - 2 - Rückleuchte
- 77 00 526 413 - 2 - Stoplicht
- 77 00 526 412 - 2 - Blinkleuchte

(65) R 2134 |
R 2135 | 13/102

Die Anbringung dieses Teiles bedingt die Montage von :

- 77 00 522 301 - 1 - Standlicht vorne rechts
- 77 00 522 302 - 1 - Standlicht vorne links
- 77 00 519 412 - 2 - Blinkleuchte
- 08 55 620 800 - 2 - Parkleuchte
- 77 00 365 009 - 2 - Rückleuchte
- 77 00 526 413 - 2 - Stoplicht
- 77 00 526 412 - 2 - Blinkleuchte.

(66) R 2134 |
R 2135 | 41/240.

Die Anbringung dieses Teiles bedingt die Montage von :

- 77 00 519 406 - 1 - Standlicht vorne rechts
- 77 00 519 407 - 1 - Standlicht vorne links
- 08 54 626 500 - 2 - Blinkleuchte
- 08 55 620 800 - 2 - Parkleuchte
- 77 01 365 010 - 2 - Rückleuchte
- 08 54 576 100 - 2 - Stoplicht

(67) R 2134 | 10/11/12/13/15/18/20/21/22/24/26
27/28/29/100/101/102/103/120/122
R 2135 | 130/200/201/202/203/204/207/211
220/230/231.

Die Anbringung dieses Teiles bedingt die Montage von :

- 77 01 981 072 - 1 - Vorderer Kabelstrang des Motors
- 77 01 981 076 - 1 - Kabelstrang des Fahrgestells

(68) R 2134 |
R 2135 | 30/40/41/42/140/240/241/242.

Die Anbringung dieses Teiles bedingt die Montage von :

- 77 01 981 081 - 1 - Vorderer Kabelstrang des Motors
- 77 01 981 076 - 1 - Kabelstrang des Fahrgestells

(69) R 2134 |
R 2135 | 14/121.

Die Anbringung dieses Teiles bedingt die Montage von :

- 77 01 981 072 - 1 - Vorderer Kabelstrang des Motors
- 77 01 981 080 - 1 - Kabelstrang des Fahrgestells.



06.04

A P.R. 810

(21) MOT 688.01 nr. 1 til MOT nr. 83.762.

Ekstra dele :

06 08 331 902 - 2 -
06 08 349 302 - 2 -
10 81 301 080 - 2 -

Følgende operation udføres :

Hullerne i forbroen til fatsgøring af motoren
udbores til lo 10,5 mm.

(23) Denne strømfordeler er mærket med to bogstaver
og et tal.

Mærkingen bankes in i strømfordelerens hus.

a) Det første bogstav angiver måneden :

A = Januar G = Juli
B = Februar H = August
C = Marts I = September
D = April J = Oktober
E = Maj K = November
F = Juni L = December

b) Tallet angiver året :

E : 5 = 1965.

c) Det andet bogstav angiver leverandørens
ændring :

B = I.S.O.

Denne mærkning skal anvendes som
henvisningsnummer.

(43) Indtil serienummer 16.401, undtagen nr. 16.389
og 16.396.

Montering af en "Tripode" transmissionsaksel
nødvendiggør montering af :

a) For udstyrsnummer :

R 2134 | 10/11/15/18/20/21/22/24/26/27/28
29/41/100/101/103/122/130/200
R 2135 | 201/202/203/204/207/211/220/230
231/240.

77 00 504 575 - 1 -
77 01 452 152 - 1 -

b) For udstyrsnummer :

R 2134 | 12/13/14/30/40/42/70/80/81/84/86
88/89/102/120/121/140/241/242
R 2135 | 700/800/801/803/807/810/811.

77 00 504 801 - 1 -
77 00 508 387 - 1 -
77 00 508 389 - 1 -
77 00 509 485 - 1 -

(55) Ikke monteret i serie.

(63) R 2134, R 2135.

Montering af denne del nødvendiggør montering
af :

- 77 00 525 876 - 1 - Højre refleksglas
- 77 00 525 878 - 1 - Venstre refleksglas
- 77 00 522 221 - 1 - Kontakt
- 77 00 523 489 - 1 - Afstandsstykke
- 08 54 531 300 - 1 - Samledåse
- 77 01 980 645 - 1 - Bag. v. ledningsnet
- 77 01 980 646 - 1 - Bag. h. ledningsnet

(64)

R 2134 | 10/11/12/14/15/18/20/21/22/24/26
27/28/29/20/40/42/100/101/103/120
R 2135 | 121/122/130/140/200/201/202/203
204/207/211/220/230/231/241/242.

Montering af denne del nødvendiggør montering
af :

- 77 00 519 406 - 1 - Højre forlygte
- 77 00 519 407 - 1 - Venstre forlygte
- 77 00 519 412 - 2 - Blinklyspære
- 08 55 620 800 - 2 - Positionsllyspære
- 77 00 365 009 - 2 - Baglygte
- 77 00 526 413 - 2 - Stoplyspære
- 77 00 526 412 - 2 - Blinklyspære

(65) R 2134 |
R 2135 | 13/102.

Montering af denne del nødvendiggør montering
af :

- 77 00 522 301 - 1 - Højre forlygte
- 77 00 522 302 - 1 - Venstre forlygte
- 77 00 519 412 - 2 - Blinklyspære
- 08 55 620 800 - 2 - Positionsllyspære
- 77 00 365 009 - 2 - Baglygte
- 77 00 526 413 - 2 - Stoplyspære
- 77 00 526 412 - 2 - Blinklyspære.

06.04

A P.R. 810



(66) R 2134 |
R 2135 | 41/240

Montering af denne del nødvendiggør montering
af :

- 77 00 519 406 - 1 - Højre forlygte
- 77 00 519 407 - 1 - Venstre forlygte
- 08 54 626 500 - 2 - Blinklyspære
- 08 55 620 800 - 2 - Positionsllyspære
- 77 01 365 010 - 2 - Baglygte
- 08 54 576 100 - 2 - Stoplyspære

(67) R 2134 | 10/11/12/13/15/18/20/21/22/24/26
27/28/29/100/101/102/103/120/122
R 2135 | 130/200/201/202/203/204/207/211
220/230/231.

Montering af denne del nødvendiggør montering
af :

- 77 01 981 072 - 1 - For. ledningsnet til motor
- 77 01 981 076 - 1 - Ledningsnet, chassis

(68) R 2134 |
R 2135 | 30/40/41/42/140/240/241/242.

Montering af denne del nødvendiggør montering
af :

- 77 01 981 081 - 1 - For. ledningsnet til motor
- 77 01 981 076 - 1 - Ledningsnet, chassis.

(69) R 2134 |
R 2135 | 14/121

Montering af denne del nødvendiggør montering
af :

- 77 01 981 072 - 1 - For. ledningsnet til motor
- 77 01 981 080 - 1 - Ledningsnet, chassis.



06. 05

A P.R. 810

06. 05

A P.R. 810



(21) MOT 688.01 n° 1 a MOT n° 83.762.

Piezas a prever en suplemento :

06 08 331 902 - 2 -

06 08 349 302 - 2 -

10 81 301 080 - 2 -

Operación a efectuar :

Escariar a 10,5 mm los agujeros del travesaño delantero de fijación del motor.

(23) Este distribuidor de encendido lleva una marca de dos letras y un número.

La marca va grabada en el cárter del distribuidor de encendido.

a) La primera letra indica el mes :

A = Enero	G = Julio
B = Febrero	H = Agosto
C = Marzo	I = Septiembre
D = Abril	J = Octubre
E = Mayo	K = Noviembre
F = Junio	L = Diciembre

b) El número indica el año :

E. : 5 = 1965.

c) La segunda letra indica la modificación del proveedor :

B = I.S.O.

Esta marca debe aplicarse como cifra de aplicación.

(43) Hasta el vehículo N° 16.401, excepto los N° 16.389 y 16.396.

La adaptación de una transmisión "Tripode" en el lado derecho del vehículo requiere el montaje de :

a) Para equipos :

	10/11/15/18/20/21/22/24/26/27/28
R 2134	29/41/100/101/103/122/130/200/201
R 2135	202/203/204/207/211/220/230/231
	240.

77 00 504 575 - 1 -

77 01 452 152 - 1 -

b) Para equipos :

	12/13/14/30/40/42/70/80/81/84/86
R 2134	88/89/102/120/121/140/241/242/700
R 2135	800/801/803/807/810/811.

77 00 504 801 - 1 -

77 00 508 387 - 1 -

77 00 508 389 - 1 -

77 00 509 485 - 1 -

(55) No montado en serie.

(63) R 2134, R 2135.

La adaptación de esta pieza requiere el montaje de :

- 77 00 525 876 - 1 - Catadióptrico derecho

- 77 00 525 878 - 1 - Catadióptrico izquierdo

- 77 00 522 221 - 1 - Conmutador

- 77 00 523 489 - 1 - Separador

- 08 54 531 300 - 1 - Placa de empalme

- 77 01 980 645 - 1 - Cableado trasero izquierdo

- 77 01 980 646 - 1 - Cableado trasero derecho.

(64)	10/11/12/14/15/18/20/21/22/24/26
R 2134	27/28/29/30/40/42/100/101/103/120
R 2135	121/122/130/140/200/201/202/203
	204/207/211/220/230/231/241/242.

La adaptación de esta pieza requiere el montaje de :

- 77 00 519 406 - 1 - Luz delantera derecha

- 77 00 519 407 - 1 - Luz delantera izquierda

- 77 00 519 412 - 2 - Luz de dirección

- 08 55 620 800 - 2 - Luz de posición

- 77 00 365 009 - 2 - Luz trasera

- 77 00 526 413 - 2 - Luz de stop

- 77 00 526 412 - 2 - Luz de dirección

(65)	R 2134	13/102
	R 2135	

La adaptación de esta pieza requiere el montaje de :

- 77 00 522 301 - 1 - Luz delantera derecha

- 77 00 522 302 - 1 - Luz delantera izquierda

- 77 00 519 412 - 2 - Luz de dirección

- 08 55 620 800 - 2 - Luz de posición

- 77 00 365 009 - 2 - Luz trasera

- 77 00 526 413 - 2 - Luz de stop

- 77 00 526 412 - 2 - Luz de dirección.

(66)	R 2134	41/240.
	R 2135	

La adaptación de esta pieza requiere el montaje de :

- 77 00 519 406 - 1 - Luz delantera derecha

- 77 00 519 407 - 1 - Luz delantera izquierda

- 08 54 626 500 - 2 - Luz de dirección

- 08 55 620 800 - 2 - Luz de posición

- 77 01 365 010 - 2 - Luz trasera

- 08 54 576 100 - 2 - Luz de stop

(67)	10/11/12/13/15/18/20/21/22/24/26
R 2134	27/28/29/100/101/102/103/120/122
R 2135	130/200/201/202/203/204/207/211
	220/230/231.

La adaptación de esta pieza requiere el montaje de :

- 77 01 981 072 - 1 - Cableado delantero motor

- 77 01 981 076 - 1 - Cableado chasis

(68)	R 2134	30/40/41/42/140/240/241/242
	R 2135	

La adaptación de esta pieza requiere el montaje de :

- 77 01 981 081 - 1 - Cableado delantero motor

- 77 01 981 076 - 1 - Cableado chasis

(69)	R 2134	14/121.
	R 2135	

La adaptación de esta pieza requiere el montaje de :

- 77 01 981 072 - 1 - Cableado delantero motor

- 77 01 981 080 - 1 - Cableado chasis.



06.06

A P.R. 810

06.06

A P.R. 810



(21) MOT 688.01 da n° 1 MOT n° 83.762.

Parti di ricambio da prevedere in supplemento :
06 08 331 902 - 2 -
06 08 349 302 - 2 -
10 81 301 080 - 2 -

Operazione da effettuare :
Alesare a 10,5 mm i fori della traversa anteriore di fissaggio del motore.

(23) Lo spinterogeno è contrassegnato da due lettere e una cifra.

Il contrassegno è inciso sul carter dello spinterogeno.

a) La prima lettera indica il mese :

A = Gennaio G = Luglio
B = Febbraio H = Agosto
C = Marzo I = Settembre
D = Aprile J = Ottobre
E = Maggio K = Novembre
F = Giugno L = Dicembre

b) La cifra indica l'anno :
E. : 5 = 1965.

c) La seconda lettera indica la modifica del fornitore :
B = I.S.O.

Questo contrassegno è da considerare come cifra di applicazione.

(43) Fino al veicolo N° 16.401, eccetto i N° 16.389 e 16.396.

L'adattamento di una trasmissione "tripode" sul lato destro del veicolo richiede il montaggio.

a) per gli equipaggiamenti

R 2134 | 10/11/15/18/20/21/22/24/26/27/28
29/41/100/101/103/122/130/200
R 2135 | 201/202/203/204/207/211/220/230
231/240.

77 00 504 575 - 1 -
77 01 452 152 - 1 -

b) per gli equipaggiamenti :

R 2134 | 12/13/14/30/40/42/70/80/81/84/86
88/89/102/120/121/140/241/242
R 2135 | 700/800/801/803/807/810/811.

77 00 504 801 - 1 -
77 00 508 387 - 1 -
77 00 508 389 - 1 -
77 00 509 485 - 1 -

(55) Non montato in serie.

(63) R 2134, R 2135.

L'adattamento di questo particolare richiede il montaggio di :

- 77 00 525 876 - 1 - Catarifrangente destro
- 77 00 525 878 - 1 - Catarifrangente sinistro
- 77 00 522 221 - 1 - Commutatore
- 77 00 523 489 - 1 - Distanziale
- 08 54 531 300 - 1 - Morsettiera
- 77 01 980 645 - 1 - Fascio fili posteriore sinistro
- 77 01 980 646 - 1 - Fascio fili posteriore destro.

(64)

R 2134 | 10/11/12/14/15/18/20/21/22/24/26
27/28/29/30/40/42/100/101/103/120
R 2135 | 121/122/130/140/200/201/202/203
204/207/211/220/230/231/241/242.

L'adattamento di questo particolare richiede il montaggio di :

- 77 00 519 406 - 1 - Fanalino di posizione anteriore destro
- 77 00 519 407 - 1 - Fanalino di posizione anteriore sinistro
- 77 00 519 412 - 2 - Lampadina indicatore di direzione
- 08 55 620 800 - 2 - Luce d'ingombro
- 77 00 365 009 - 2 - Fanalino posteriore
- 77 00 526 413 - 2 - Luce di arresto
- 77 00 526 412 - 2 - Lampadina indicatore di direzione.

(65) R 2134 | 13/102
R 2135

L'adattamento di questo particolare richiede il montaggio di :

- 77 00 522 301 - 1 - Fanalino di posizione anteriore destro
- 77 00 522 302 - 1 - Fanalino di posizione anteriore sinistro

- 77 00 519 412 - 2 - Lampadina indicatore di direzione
- 08 55 620 800 - 2 - Luce d'ingombro
- 77 00 365 009 - 2 - Fanalino posteriore
- 77 00 526 413 - 2 - Luce di arresto
- 77 00 526 412 - 2 - Lampadina indicatore di direzione.

(66) R 2134 | 41/240.
R 2135

L'adattamento di questo particolare richiede il montaggio di :

- 77 00 519 406 - 1 - Fanalino di posizione anteriore destro
- 77 00 519 407 - 1 - Fanalino di posizione anteriore sinistro
- 08 54 626 500 - 2 - Lampadina indicatore di direzione
- 08 55 620 800 - 2 - Luce d'ingombro
- 77 01 365 010 - 2 - Fanalino posteriore
- 08 54 576 100 - 2 - Luce di arresto

(67) R 2134 | 10/11/12/13/15/18/20/21/22/24/26
27/28/29/100/101/102/103/120/122
R 2135 | 130/200/201/202/203/204/207/211
220/230/231.

L'adattamento di questo particolare richiede il montaggio di :
- 77 01 981 072 - 1 - Fascio fili anteriore motore
- 77 01 981 076 - 1 - Fascio fili telaio

(68) R 2134 | 30/40/41/42/140/240/241/242.
R 2135

L'adattamento di questo particolare richiede il montaggio di :

- 77 01 981 081 - 1 - Fascio fili anteriore motore
- 77 01 981 076 - 1 - Fascio fili telaio

(69) R 2134 | 14/121.
R 2135

L'adattamento di questo particolare richiede il montaggio di :
- 77 01 981 072 - 1 - Fascio fili anteriore motore
- 77 01 981 080 - 1 - Fascio fili telaio.



06.07

A P.R. 810

06.07

A P.R. 810



(21) MOT 688.01 n° 1 tot MOT n° 83.762.

Extra te bestellen onderdelen :

06 08 331 902 - 2 -

06 08 349 302 - 2 -

10 81 301 080 - 2 -

Uit te voeren werkzaamheid :

Boor de gaten van de voorste bevestigingstraverse van de motor uit tot 10,5 mm.

(23) Deze stroomverdeler is gemerkt d.m.v. twee letters en een cijfer.

De merktekens zin op het stroomverdelerhuis ingeslagen.

a) De eerste letter duidt de maand aan :

A = Januari	G = Juli
B = Februari	H = Augustus
C = Maart	I = September
D = April	J = Oktober
E = Mei	K = November
E = Juni	L = December

b) Het cijfer geeft het jaar aan :

E. : 5 = 1965.

c) De tweede letter geeft de wijziging van de leverancier aan :

C B = I.S.O.

Deze merktekens dienen als toepassingscijfer.

(43) Wil men aan de rechterzijde van de auto een "Tripode" aandrijfjas monteren, dan moet men bij auto's met een lager fab.no. dan 16.401 (uitgezonderd de nummers 16.389 en 16.396) het volgende er bij monteren :

a) Bij de uitrustingsnummers :

R 2134	10/11/15/18/20/21/22/24/26/27/28
R 2135	29/41/100/101/103/122/130/200
	201/202/203/204/207/211/220/230
	231/240.

77 00 504 575 - 1 -

77 01 452 152 - 1 -

b) Bij de uitrustingsnummers :

R 2134	12/13/14/30/40/42/70/80/81/84/86
R 2135	88/98/102/120/121/140/241/242
	700/800/801/803/807/810/811.

77 00 504 801 - 1 -

77 00 508 387 - 1 -

77 00 508 389 - 1 -

77 00 509 485 - 1 -

(55) Niet in serie gemonteerd.

(63) R 2134, R 2135.

Voor het monteren van dit onderdeel zijn ook de volgende onderdelen nodig :

- 77 00 525 876 - 1 - rechter reflector

- 77 00 525 878 - 1 - linker reflector

- 77 00 522 221 - 1 - schakelaar

- 77 00 523 489 - 1 - vulstukje

- 08 54 531 300 - 1 - aansluitblokje

- 77 01 980 645 - 1 - kabelbundel links achter

- 77 01 980 646 - 1 - kabelbundel rechts achter

(64)	10/11/12/14/15/18/20/21/22/24/26
R 2134	27/28/29/30/40/42/100/101/103/120
R 2135	121/122/130/140/200/201/202/203
	204/207/211/220/230/231/241/242.

Voor het monteren van dit onderdeel zijn ook de volgende onderdelen nodig :

- 77 00 519 406 - 1 - stadslicht/knipperlicht rechts

- 77 00 519 407 - 1 - stadslicht/knipperlicht links

- 77 00 519 412 - 2 - lamp knipperlicht

- 08 55 620 800 - 2 - lamp stadslicht

- 77 00 365 009 - 2 - achterlicht

- 77 00 526 413 - 2 - lamp stoplicht

- 77 00 526 412 - 2 - lamp knipperlicht

(65)	R 2134	13/102.
	R 2135	

Voor het monteren van dit onderdeel zijn ook de volgende onderdelen nodig :

- 77 00 522 301 - 1 - stadslicht/knipperlicht rechts

- 77 00 522 302 - 1 - stadslicht/knipperlicht links

- 77 00 519 412 - 2 - lamp knipperlicht

- 08 55 620 800 - 2 - lamp stadslicht

- 77 00 365 009 - 2 - achterlicht

- 77 00 526 413 - 2 - lamp stoplicht

- 77 00 526 412 - 2 - lamp knipperlicht.

(66)	R 2134	41/240.
	R 2135	

Voor het monteren van dit onderdeel zijn ook de volgende onderdelen nodig :

- 77 00 519 406 - 1 - stadslicht/knipperlicht rechts

- 77 00 519 407 - 1 - stadslicht/knipperlicht links

- 08 54 626 500 - 2 - lamp knipperlicht

- 08 55 620 800 - 2 - lamp stadslicht

- 77 01 365 010 - 2 - achterlicht

- 08 54 576 100 - 2 - lamp stoplicht

(67)	10/11/12/13/15/18/20/21/22/24/26
R 2134	27/28/29/100/101/102/103/120/122
R 2135	130/200/201/202/203/204/207/211
	220/230/231.

Voor het monteren van dit onderdeel zijn ook de volgende onderdelen nodig :

- 77 01 981 072 - 1 - Voorste kabelbundel, motor

- 77 01 981 076 - 1 - kabelbundel chassis

(68)	R 2134	30/40/41/42/140/240/241/242.
	R 2135	

Voor het monteren van dit onderdeel zijn ook de volgende onderdelen nodig :

- 77 01 981 081 - 1 - Voorste kabelbundel, motor

- 77 01 981 076 - 1 - kabelbundel chassis

(69)	R 2134	14/121.
	R 2135	

Voor het monteren van dit onderdeel zijn ook de volgende onderdelen nodig :

- 77 01 981 072 - 1 - voorste kabelbundel, motor

- 77 01 981 080 - 1 - kabelbundel chassis.



06.08

A P.R. 810

06.08

A P.R. 810



(21) MOT 688.01 Fr. nr. 1 to.m. MOT nr. 83.762.

Beställ även följande delar :

06 08 331 902 - 2 -
06 08 349 302 - 2 -
10 81 301 080 - 2 -

Tilläggsarbete :

Borra upp hålen för främre motorbalken till
Ø 10,5 mm.

(23) En märkning bestående av två bokstäver och en siffra finns stansade på fördelarhuset.

a) Första bokstaven anger tillverkningsmånad :

A = Januari G = Juli
B = Februari H = Augusti
C = Mars I = September
D = April J = Oktober
E = Maj K = November
F = Juni L = December

b) Siffran årtalet :

E : 5 = 1965.

c) Sista bokstaven anger seriebeteckningen efter de olika modifikationerna :

B = I.S.O.

Denna märkning skall användas som utgångsnummer.

(43) Till nr. 16.401 utom 16.389 till 16.396.
Montering av en tripodknut på högra sidan kräver även följande delar :

a) För utrustningarna nr :

R 2134 | 10/11/15/18/20/21/22/24/26/27/28
29/41/100/101/103/122/130/200
R 2135 | 201/202/203/204/207/211/220/230
231/240.

77 00 504 575 - 1 -
77 01 452 152 - 1 -

b) För utrustningarna nr :

R 2134 | 12/13/14/30/40/42/70/80/81/84/86
88/89/102/120/121/140/241/242
R 2135 | 700/800/801/803/807/810/811.

77 00 504 801 - 1 -
77 00 508 387 - 1 -
77 00 508 389 - 1 -
77 00 509 485 - 1 -

(55) Ej monterad i serie.

(63) R 2134, R 2135.

Montering av denna del kräver även montering av :

- 77 00 525 876 - 1 - reflex, höger
- 77 00 525 878 - 1 - reflex, vänster
- 77 00 522 221 - 1 - omkopplare
- 77 00 523 489 - 1 - distanshylsa
- 08 54 531 300 - 1 - kopplingsplint
- 77 01 980 645 - 1 - bakre kabelhärva, vänster
- 77 01 980 646 - 1 - bakre kabelhärva, höger.

(64)

R 2134 | 10/11/12/14/15/18/20/21/22/24/26
27/28/29/30/40/42/100/101/103/120
R 2135 | 121/122/130/140/200/201/202/203
204/207/211/220/230/231/241/242.

Montering av denna del kräver även montering av :

- 77 00 519 406 - 1 - blinkers, fram, höger
- 77 00 519 407 - 1 - blinkers, fram, vänster
- 77 00 519 412 - 2 - blinkerslampa
- 08 55 620 800 - 2 - positionsljuslampa
- 77 00 365 009 - 2 - bakljuslampa
- 77 00 526 413 - 2 - stoppljuslampa
- 77 00 526 412 - 2 - blinkerslampa.

(65) R 2134 |
R 2135 | 13/102.

Montering av denna del kräver även montering av :

- 77 00 522 301 - 1 - blinkers, fram, höger
- 77 00 522 302 - 1 - blinkers, fram, vänster
- 77 00 519 412 - 2 - blinkerslampa
- 08 55 620 800 - 2 - positionsljuslampa
- 77 00 365 009 - 2 - bakljuslampa
- 77 00 526 413 - 2 - stoppljuslampa
- 77 00 526 412 - 2 - blinkerslampa.

(66) R 2134 |
R 2135 | 41/240.

Montering av denna del kräver även montering av :

- 77 00 519 406 - 1 - blinkers, fram, höger
- 77 00 519 407 - 1 - blinkers, fram, vänster
- 08 54 626 500 - 2 - blinkerslampa
- 08 55 620 800 - 2 - positionsljuslampa
- 77 01 365 010 - 2 - bakljuslampa
- 08 54 576 100 - 2 - stoppljuslampa

(67) R 2134 | 10/11/12/13/15/18/20/21/22/24/26
27/28/29/100/101/102/103/120/122
R 2135 | 130/200/201/202/203/204/207/211
220/230/231.

Montering av denna del kräver även montering av :

- 77 01 981 072 - 1 - främre kabelhärva (motordel)
- 77 01 981 076 - 1 - kabelhärva vid bottenplatta.

(68) R 2134 |
R 2135 | 30/40/41/42/140/240/241/242.

Montering av denna del kräver även montering av :

- 77 01 981 081 - 1 - främre kabelhärva (motordel)
- 77 01 981 076 - 1 - kabelhärva vid bottenplatta.

(69) R 2134 |
R 2135 | 14/121.

Montering av denna del kräver även montering av :

- 77 01 981 072 - 1 - främre kabelhärva (motordel)
- 77 01 981 080 - 1 - kabelhärva vid bottenplatta.

FRANÇAIS

La plaque ovale est la clef d'utilisation du catalogue de Pièces de Rechange.

DANSK

Den ovale plade er nøglen til Reservedels-Kataloget.

DEUTSCH

Das ovale Schild ist der Schlüssel für die Handhabung des Ersatzteilkataloges.

ENGLISH

The oval number plate is the key to using the spare parts catalogue.

ESPAÑOL

La placa oval es la llave que da paso al buen empleo del catalogo de Piezas de Repuesto.

ITALIANO

La piastrina ovale è la chiave per l'impiego del catalogo dei pezzi di ricambio.

NEDERLANDS

Het fabricagenummer is de sleutel van het onderdelenboek.

SVENSKA

Den ovala plåten är nyckeln till Er reservdelskatalog och leder Er till rätt reservdel.



FRANÇAIS

Le Réseau Renault s'engage par contrat à n'utiliser et ne mettre en vente que des pièces d'origine et à le garantir sur ses factures.

Les pièces d'origine sont indispensables au triple point de vue de la nuance de matière, de la qualité du traitement thermique et de la précision d'exécution garantissant l'interchangeabilité et la bonne tenue à l'usage.

Les pièces distribuées par la Régie Renault sont facilement identifiables :

Soit pour les pièces conditionnées par l'étiquette (1).

Soit par une marque de fabrique frappée ou gravée (2).

DANSK

Renault - forhandlerne forpligter sig kontraktligt til kun at benytte og sælge originale reservedele og at garantere herfor på deres fakturaer.

Originale reservedele er absolut nødvendige ud fra 3 synspunkter, nemlig stofernes nuance, hærningens kvalitet og den nøjagtige udførelse, der garanterer indbyrdes udskiftning af delene og god holdbarhed under brugen.

Dele, der udsendes af Renault-fabrikkerne, er lette at identificere :

Eller ved de emballerede dele ved hjælp af en etikette (1).

Enten ved et præget eller ingravert fabriksmærke (2).

DEUTSCH

Die Renault-Werkstätten sind vertraglich verpflichtet, für Fahrzeuge unserer Marke ausschliesslich Original-Renault-Ersatzteile zu verwenden oder zu verkaufen.

Original-Ersatzteile sind in vierfacher Hinsicht unerlässlich: in Kontrollen geprüft, gleiches Material, Qualität der thermischen Bearbeitung und präzisen Ausführung, wodurch die Austauschbarkeit und Haltbarkeit garantiert werden.

Original-Renault-Ersatzteile sind gekennzeichnet :

Oder durch einen Schriftzug der Firma (1).

Durch ein eingegossene oder gestanzte Fabrikmarke (2).

ENGLISH

The Renault network accepts, under contract neither to fit nor sell any parts other than genuine Renault spare parts and to guarantee this on its invoices.

Genuine Renault parts must be used because the specifications of the materials from which they are made, the quality of their heat treatment and the precision of their machining guarantee that they will be fully interchangeable and will have a long operating life.

Spare parts distributed by the Régie Renault are easily identifiable :

Or, for packed parts by this label (1).

Either by a stamped or engraved trademark (2).

ESPAÑOL

La Red Renault se compromete por contrato a emplear y vender únicamente piezas de origen y a garantizarlo en sus facturas.

Las piezas de origen son imprescindibles por tres motivos, matiz de la materia, calidad del tratamiento térmico y precisión del mecanizado con lo que se obtiene la intercambiabilidad y el mejor funcionamiento.

Las piezas distribuidas por Régie Renault se pueden identificar con toda facilidad :

Fuere mediante la etiqueta para las piezas empaquetadas (1).

Fuere mediante una marca de fabrica acuñada o grabada (2).

ITALIANO

La Rete di assistenza Renault s'impegna per contratto a usare e a vendere solo pezzi di ricambio originali, garantendoli in fattura.

I pezzi di ricambio originali sono indispensabili per tre ragioni: la gradazione del materiale, la qualità del trattamento termico e la precisione della lavorazione, caratteristiche che garantiscono l'intercambiabilità e il perfetto funzionamento.

I pezzi di ricambio distribuiti dalla Régie Renault sono facilmente riconoscibili :

O dall'etichetta applicata sui pezzi di ricambio (1).

O dal marchio di fabbrica inciso o stampato (2).

NEDERLANDS

De Renault-agenten hebben zich contractueel verplicht uitsluitend originele onderdelen te verkopen en deze op hun facturen te garanderen.

De originele onderdelen zijn, uit een drievoudig oogpunt bezien, beslist noodzakelijk t. w. door de soort van het gebruikte materiaal, de kwaliteit van de thermische behandeling en de precisie bij de fabricage. Hierdoor is de onderlinge verwisselbaarheid en de goede aanpassing tijdens het gebruik gegarandeerd.

De door de Renaultfabrieken verstrekte onderdelen zijn gemakkelijk te herkennen nl. :

Hetzij door middel van een etiket voor onderdelen, die aan de eisen voldoen (1).

Hetzij door een ingeslagen of gegraveerd fabrieksmerk (2).

SVENSKA

Renaults återförsäljare har genom kontrakt förbundit sig att endast saluföra original reservdelar och att garantera detta på sina fakturor.

Original resevdelar är nödvändiga ur flera synpunkter Materialkvalité, hárning och perfekt dimensionering garanterar absolut passning och god hållbarhet.

Delar, som levereras genom Régie Renault är lätta att identifiera :

Eller genom banderoll (1).

Antigen genom ett gjutet eller graverat fabriksmarke (2).





14.01

B P.R. 810

14.01

B P.R. 810



(a) { †09 88 003 000 }
 { 77 01 452 855 }
 (c) { †09 80 680 700 }
 { 77 01 452 856 }

688-01

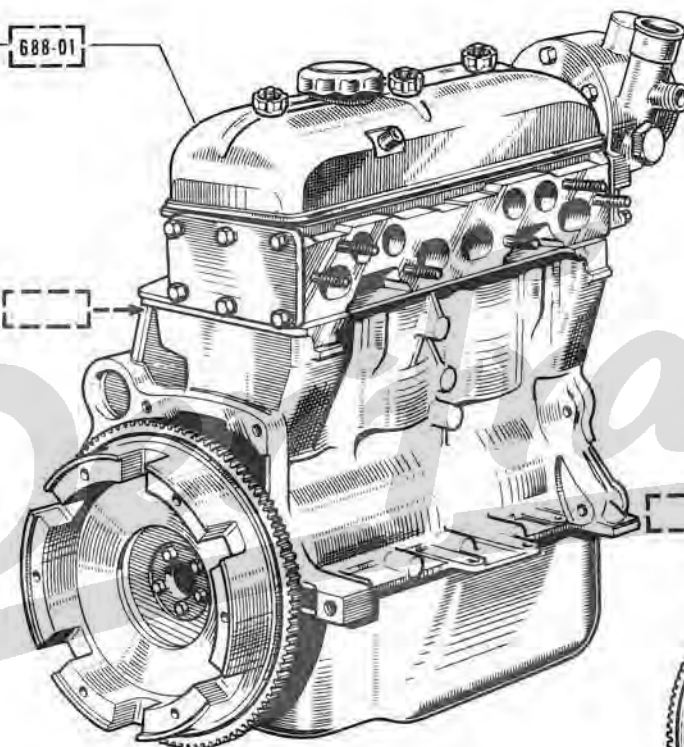

688-01

{ 09 96 093 700† } (b)
 { 77 01 452 857 }
 { 09 96 093 800† } (d)
 { 77 01 452 858 }

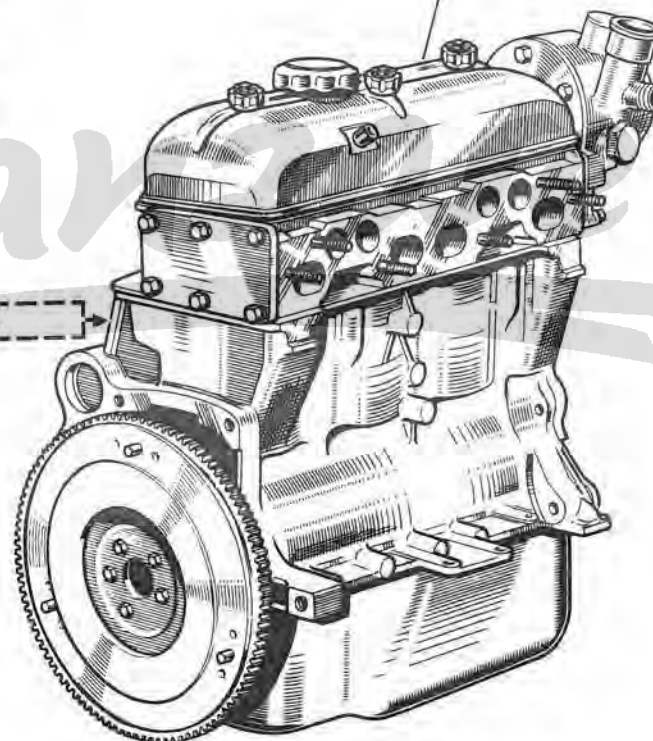

(a) R 2134,R 2135	/10/11/12/13/14/15/20/21/22/24/26/30/40/41/42/70/80/81/86	MOT 688-01 n°	1	⇔	MOT 688-01 n° 79041
(b) R 2134,R 2135	/10/11/12/13/14/15/20/21/22/24/26/30/40/41/42/70/80/81/86	MOT 688-01 n°	79042	⇔	MOT 688-01 n°
	100/101/102/103/120/121/122/140/200/201/202/203/204/207/220/240/241/242/700/800/801/803/807				
(c) R 2134,R 2135	/18/27/28/29/84/88/89	MOT 688-01 n°	1	⇔	MOT 688-01 n° 79041
(d) R 2134,R 2135	/18/27/28/29/84/88/89	MOT 688-01 n°	79042	⇔	MOT 688-01 n°
	130/211/230/231/810/811				

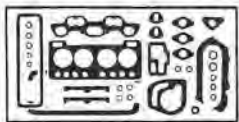

14.05

B P.R. 810

14.05

B P.R. 810

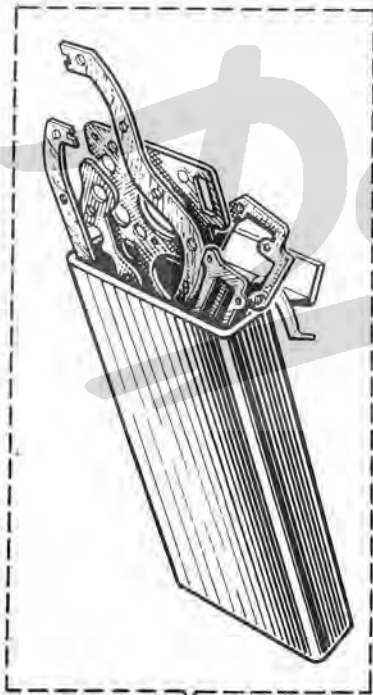
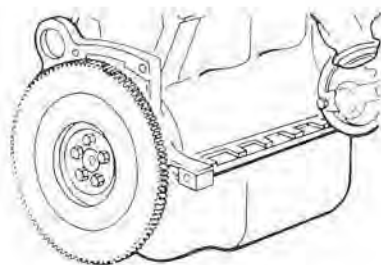
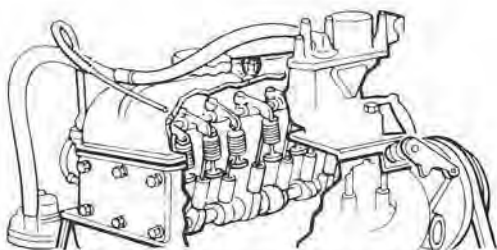
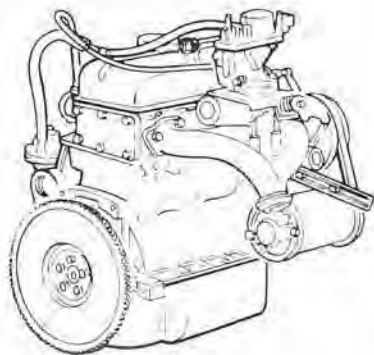
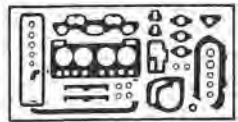

09 80 664 100

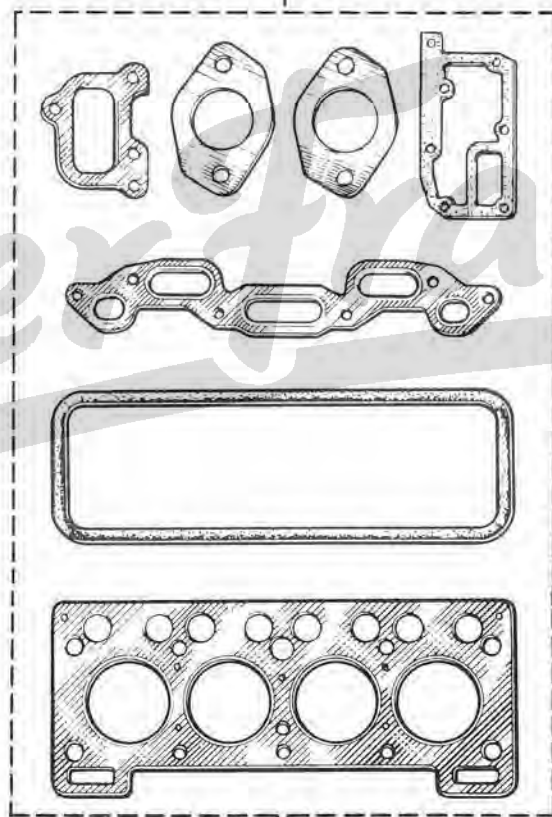

09 80 664 500

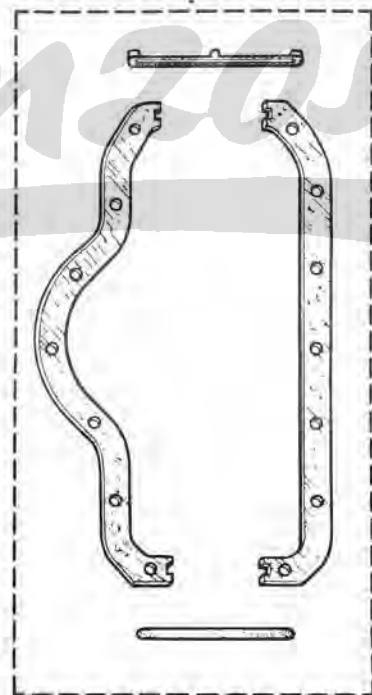

09 80 667 100

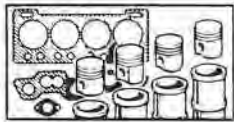

14.20

B P.R. 810



14.20

B P.R. 810

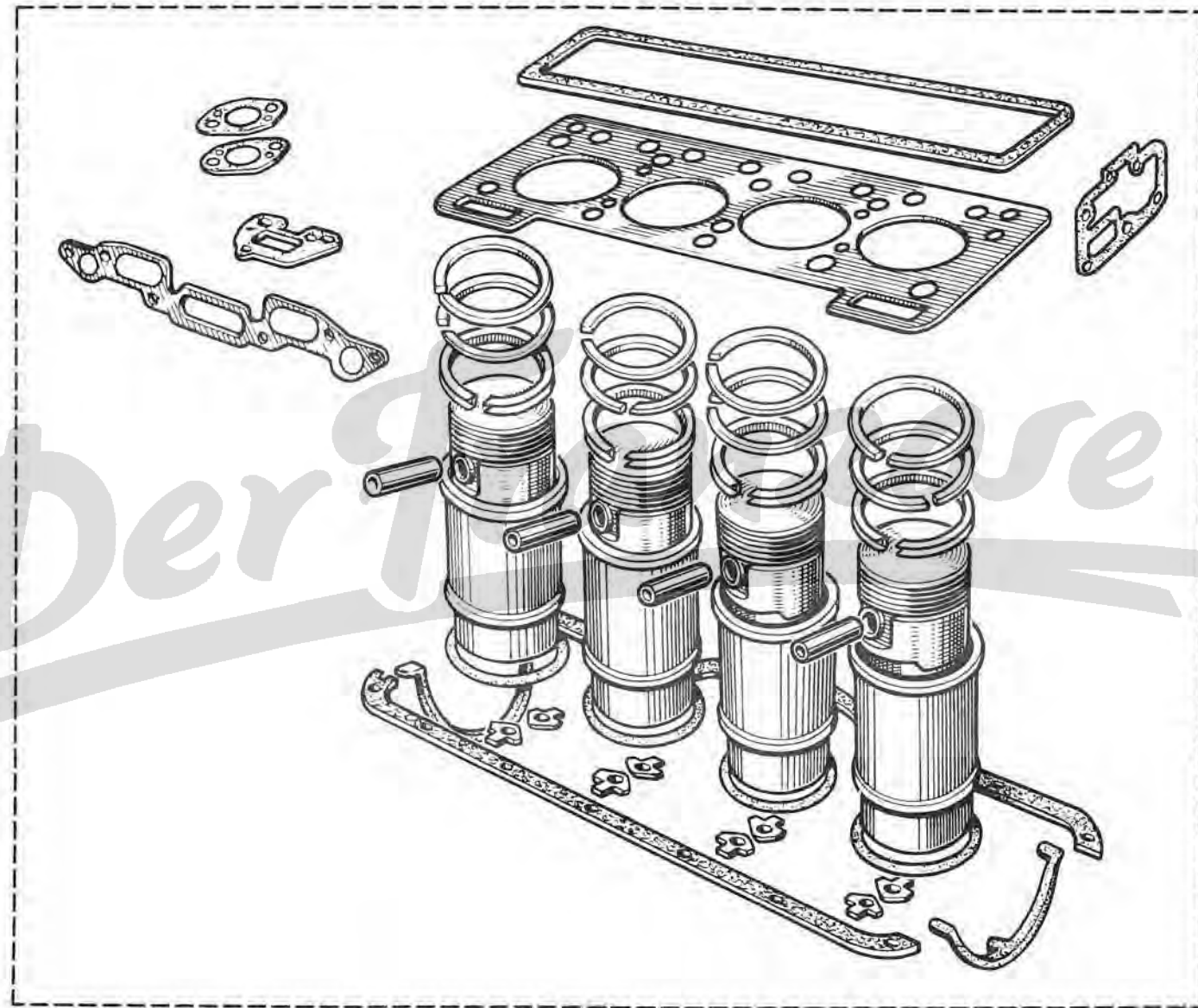

{09 96 001 500 (a)
{09 96 035 100 (b)

	10/11/12/13/14/15/20/21/22/24/26/30/40/41/42/70/80
(a) R 2134 R 2135	81/86/100/101/102/103/120/121/122/140/200/201/202
	203/204/207/220/240/241/242/700/800/801/803/807
(b) R 2134 R 2135	/18/27/28/29/84/88/89/130/211/230/231/810/811

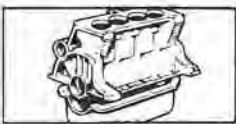

14.30

B P.R. 810

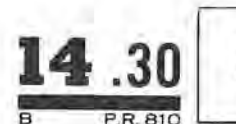

14.30

B P.R. 810

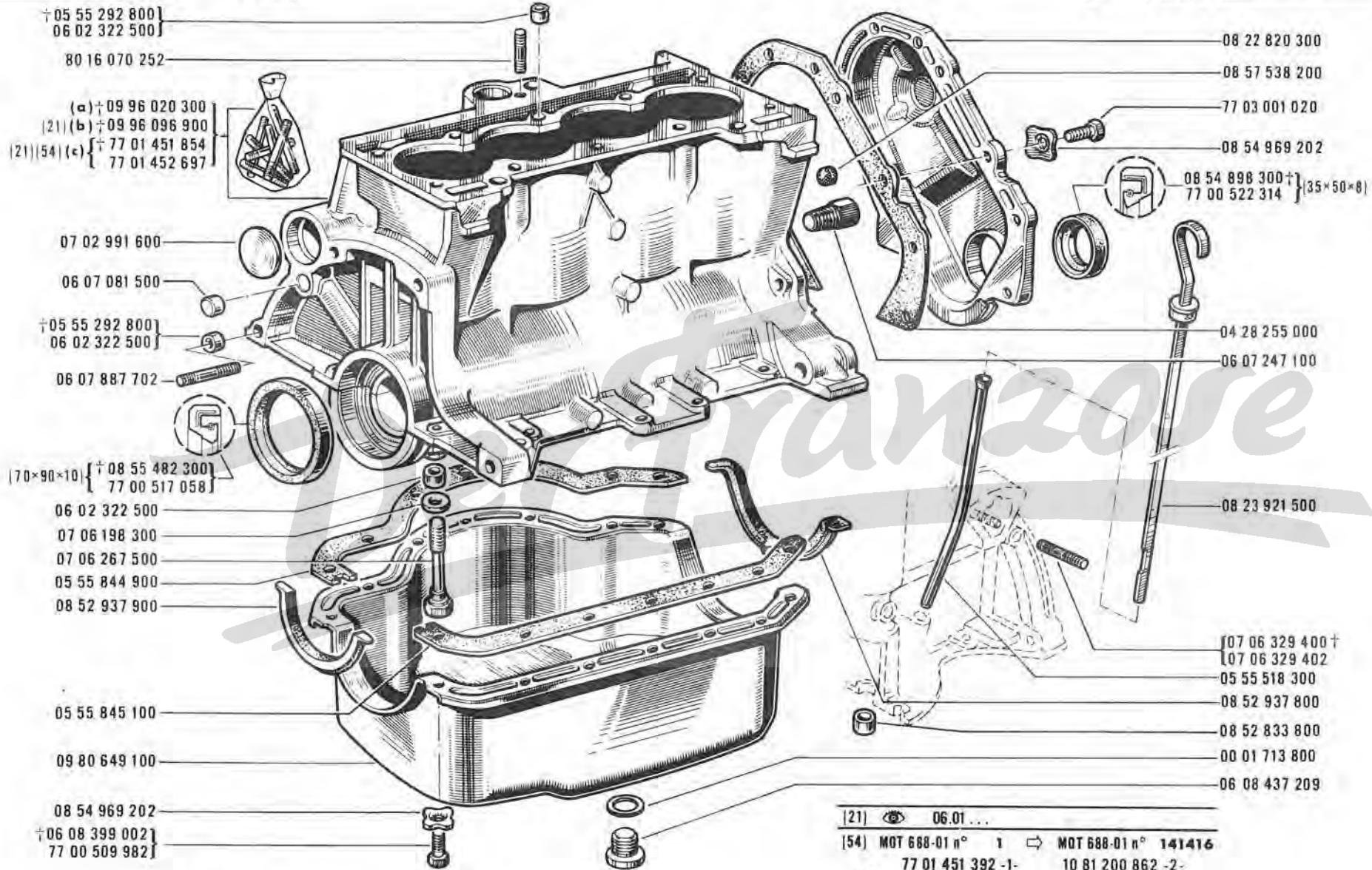

(a)	MOT 688-01 n°	1	⇔	MOT 688-01 n°	83762
(b)	MOT 688-01 n°	83763	⇔	MOT 688-01 n°	141416
(c)	MOT 688-01 n°	141417	⇔	MOT 688-01 n°	...

(21)	👁	06.01 ...	
(54)	MOT 688-01 n°	1	⇔ MOT 688-01 n° 141416
	77 01 451 392	-1-	10 81 200 862 -2-
	77 01 451 393	-1-	10 81 350 752 -2-
	77 01 451 394	-1-	77 00 505 812 -1-
	77 01 451 395	-1-	77 03 001 052 -2-
	77 01 451 396	-1-	80 80 100 752 -2-

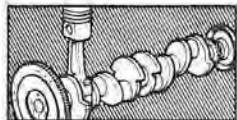

14.40

B P.R. 810

(A=70) 06 07 152 300

(A=70,1) 77 00 502 401

(A=70) { †06 08 112 700
77 00 520 420 }

(A=70,1) 77 00 502 402

† 08 54 645 000
77 00 520 424

GOECRO FK+0,1

GOE F TOP+0,1

(A=0,07) 06 07 776 500

(A=0,10) 06 07 776 600

(A=0,14) 06 07 776 700

(1) (b) 08 22 820 500

07 06 292 700

08 54 735 400

(e) 08 32 075 000

(d) 08 33 197 500



14.40

B P.R. 810

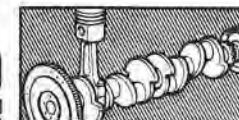

(3)

{ 07 06 312 400 †
77 00 520 421 }

06 07 801 600 (a)

{ 06 06 268 300 †

77 00 520 417

07 03 500 600

{ 06 07 531 500 †

06 07 531 502

06 07 149 100

08 21 634 000 (c)

08 33 197 300 (d)

{ 05 55 482 400 †

77 00 520 332

06 04 575 900

(3)

09 96 019 200 g=478 ⇨ 480 [8]

09 96 019 300 g=493 ⇨ 495 [8]

09 96 019 400 g=508 ⇨ 510 [8] [10]

09 96 019 500 g=523 ⇨ 525 [8] [10]

(a) MOT 688-01 n° 1 ⇨ MOT 688-01 n° 64284

(b) MOT 688-01 n° 1 ⇨ MOT 688-01 n° 79041

(c) MOT 688-01 n° 1 ⇨ MOT 688-01 n° 121126

(d) MOT 688-01 n° 121127 ⇨ MOT 688-01 n° . . .

(e) MOT 688-01 n° 79042 ⇨ MOT 688-01 n° 121126

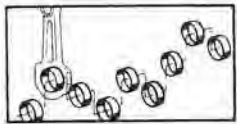

14.50

B P.R.810

14.50

B P.R.810

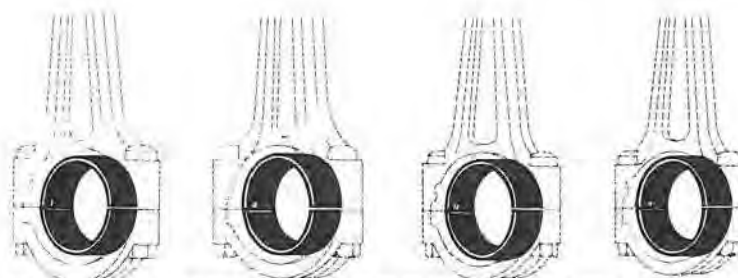

(A=44) 09 80 665 200
(A=43,75) 09 80 665 300
(A=43,5) † 09 80 665 400

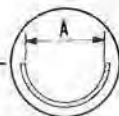

09 80 665 900 † (a) (A=2,38)
77 01 451 397 (a) (A=2,28)
77 01 451 394 (b) (A=2,78)
09 80 666 000 † (a) (A=2,40)
77 01 451 398 (a) (A=2,38)
77 01 451 395 (b) (A=2,88)
09 80 666 100 † (a) (A=2,45)
77 01 451 399 (a) (A=2,43)
77 01 451 396 (b) (A=2,93)

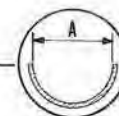
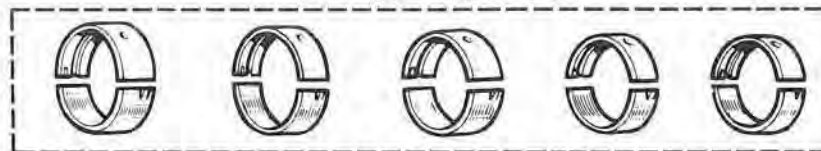

09 80 664 900 † (a) } (A=46)
77 01 451 392 (b) }
09 80 665 000 † (a) } (A=45,75)
77 01 451 393 (b) }
09 80 665 100 † (A=45,5)

(a) MOT 688-01 n° 1 ⇨ MOT 688-01 n° 141416

(b) MOT 688-01 n° 141417 ⇨ MOT 688-01 n° ...

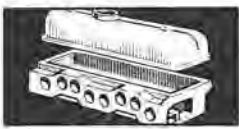

15.01.1

B P.R. 810

15.01.1

B P.R. 810

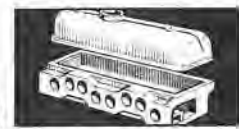

(g) { 06 07 407 702
08 52 898 300

(d) 1m 07 60 493 700

(c) { 1m 07 60 706 300
06 06 551 400
10 81 200 862
77 03 001 158

05 55 497 400

(g) 06 07 201 602

† 06 07 154 202

06 08 450 002

(1)

06 07 154 000

(55) 77 00 519 278

77 03 001 379

10 81 200 662

06 07 153 900

(55) 77 00 519 279

† 07 06 329 500

07 06 329 502

10 81 350 832

06 04 227 200

† 07 06 329 400

07 06 329 402

09 80 616 700 †



77 00 506 307 (h)



77 00 506 306 (j)

07 06 243 400

06 07 407 702

08 52 898 300

{ 08 21 691 100 † } (e)

77 00 506 570

{ 08 21 490 300 † } (b)

77 00 506 569

{ 08 21 490 200 † } (a)

77 00 506 568

06 07 218 000

07 06 305 400

{ 06 07 154 202 †

06 08 450 002

07 06 232 400

{ 09 96 018 600 †

77 01 452 189 (58) (55)

07 05 914 602 † (f)

{ 04 28 449 300 †

77 00 519 829

08 55 483 900 †

77 00 518 676

(1)

06 07 747 900 A=11
07 10 941 000 A=11,1
07 10 941 100 A=11,25

(55) 06.01 ...

(58) 77 01 452 154 -1-

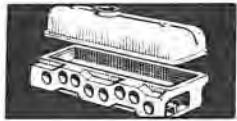

15.01.2

B P.R. 810

15.01.2

B P.R. 810



(a)	R.2134 / 70/80/81/84/86/88/89/700/800/801/803/807/810/811 R.2135 /	
(b)	R.2134 / 10/11/12/13/14/15/18/20/21/22/24/27/28/29/30/40/41/42/100/101/102/103 R.2135 / 120/121/122/130/140/200/201/202/204/207/211/220/230/231/240/241/242	
(c)	R.2134 / 40/41/42/240/241/242 R.2135 /	
(d)	R.2134 / 10/11/12/13/14/15/18/20/21/22/24/26/27/28/29/30/70/80 R.2135 / 81/84/86/88/89/100/101/102/103/120/121/122/130/140/200/201 202/203/204/207/221/220/230/231/700/800/801/803/807/810/811	
(e)	R.2134 / 26/203 R.2135 /	
(f)	MOT 688-01 n° 1 ⇨ MOT 688-01 n° 70756	(16)
(g)	R.2134 / 10/11/12/13/14/15/18/20/21/22/24/27/28/29/30/40/41/42/70/80/81/84 R.2135 / 88/89/100/101/102/103/120/121/122/130/140/200/201/202/204/207/211 220/230/231/240/241/242/700/800/801/807/810/811 26/86/203/803	MOT 688-01 n° 1 ⇨ MOT 688-01 n° 135032
(h)	R.2134 / 10/11/13/14/20/30/100/101/102/103/121/140/200 R.2135 /	
(j)	R.2134 / 12/15/18/21/22/24/26/27/28/29/120/122/130/201/202/203/204/207/211/220/230/231 R.2135 / 40/41/42/70/80/81/84/86/88/89/240/241/242/700/800/801/803/807/810/811	

?

(16) ⊕ 07 06 335 202 -3-

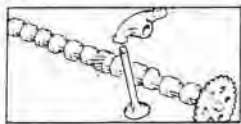

15.10

B P.R. 810

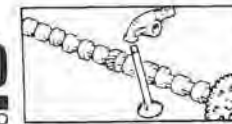

15.10

B P.R. 810

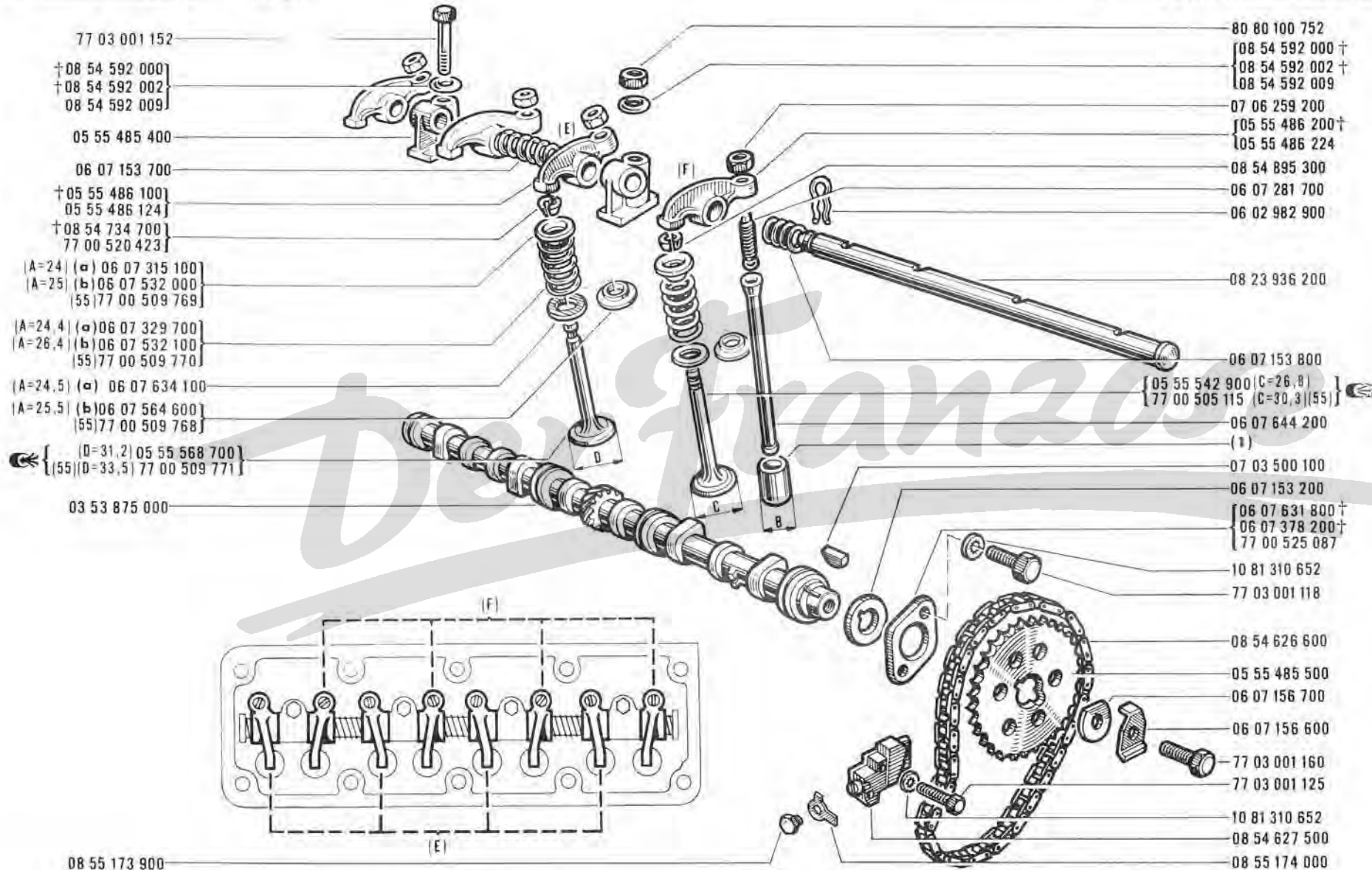

- 77 03 001 152
- †08 54 592 000
- †08 54 592 002
- 08 54 592 009
- 05 55 485 400
- 06 07 153 700
- †05 55 486 100
- 05 55 486 124
- †08 54 734 700
- 77 00 520 423
- (A=24) (a) 06 07 315 100
- (A=25) (b) 06 07 532 000
- (55) 77 00 509 769
- (A=24,4) (a) 06 07 329 700
- (A=26,4) (b) 06 07 532 100
- (55) 77 00 509 770
- (A=24,5) (a) 06 07 634 100
- (A=25,5) (b) 06 07 564 600
- (55) 77 00 509 768
- { (D=31,2) 05 55 568 700
- { (55) (D=33,5) 77 00 509 771 }
- 03 53 875 000

- 80 80 100 752
- { 08 54 592 000 †
- { 08 54 592 002 †
- { 08 54 592 009
- 07 06 259 200
- { 05 55 486 200 †
- { 05 55 486 224
- 08 54 895 300
- 06 07 281 700
- 06 02 982 900
- 08 23 936 200
- 06 07 153 800
- { 05 55 542 900 (C=26,8)
- { 77 00 505 115 (C=30,3) (55) }
- 06 07 644 200
- (1)
- 07 03 500 100
- 06 07 153 200
- { 06 07 631 800 †
- { 06 07 378 200 †
- { 77 00 525 087
- 10 81 310 652
- 77 03 001 118
- 08 54 626 600
- 05 55 485 500
- 06 07 156 700
- 06 07 156 600
- 77 03 001 160
- 77 03 001 125
- 10 81 310 652
- 08 54 627 500
- 08 55 174 000

(a) MOT 688-01 n° 1 ⇨ MOT 688-01 n° 140475
 (b) MOT 688-01 n° 140476 ⇨ MOT 688-01 n° ...

(1)
 06 05 478 200 B=19
 07 10 937 700 B=19,20

(55) 06.01 ...

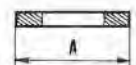

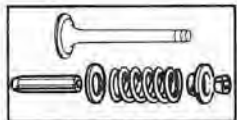

15.20

B P.R. 810

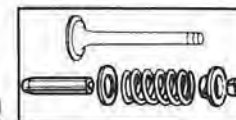

15.20

B P.R. 810

(a) { + 09 80 666 400 }
{ + 09 96 143 100 }
(b) + 09 96 143 300

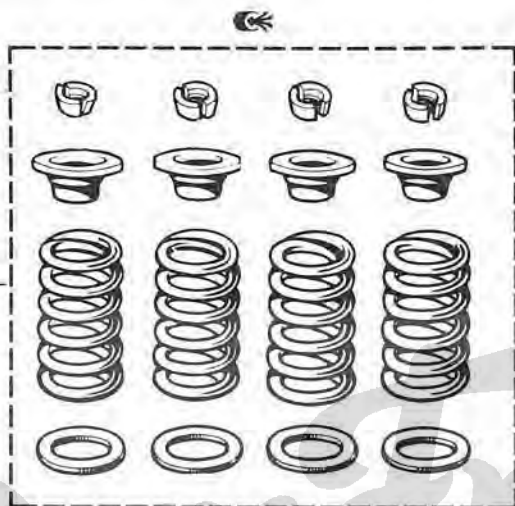

{ 09 80 666 600 + } (a)
{ 09 96 143 200 + }
09 96 143 400 + (b)

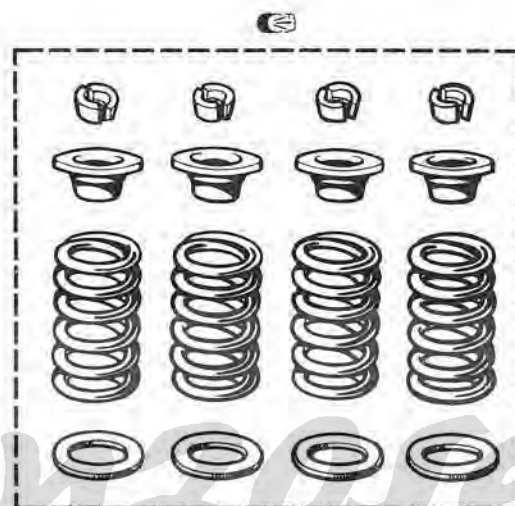

(a) MOT 688-01 n° 1 ⇨ MOT n° 140475

(b) MOT 688-01 n° 140476 ⇨ MOT n° ...



15.30

B P.R. 810

15.30

B P.R. 810



(a) { 77 03 001 116
07 03 308 100

† 06 07 201 802
77 03 001 148

06 07 457 202

77 03 001 152

9806630

6073294

6073296

10 89 020 202

8512970

6071273

† 6071503
6078573

9806707

6076428

10 81 200 862

7062841

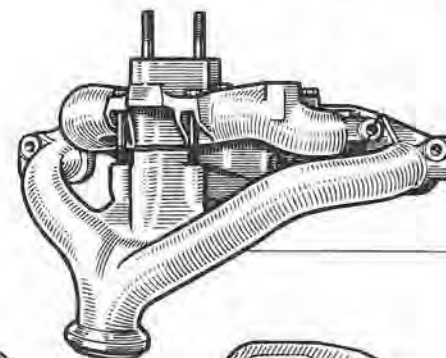

{ 09 80 662 900 (b)
09 96 064 900 (c)

8528460

8528897

07 06 296 802

(a) MOT 688-01 n° 1 ⇨ MOT 688-01 n° 81084

(b)	R 2134	10/11/12/13/14/15/18/20/21/22/24/27/28/29/30/40/41/42/70/80/81/84/86/88
	R 2135	89/100/101/102/103/120/121/122/130/140/200/201/202/204/207 211/220/230/231/240/241/242/700/800/801/803/807/810/811
(c)	R 2134	26/203
	R 2135	



15. 40

B P.R. 810

R 2134 | /26/203
R 2135 |

15. 40

B P.R. 810



08 55 511 300

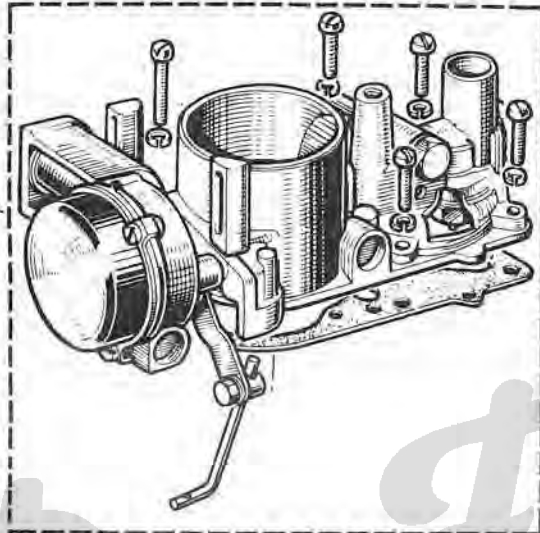

08 55 511 400 †

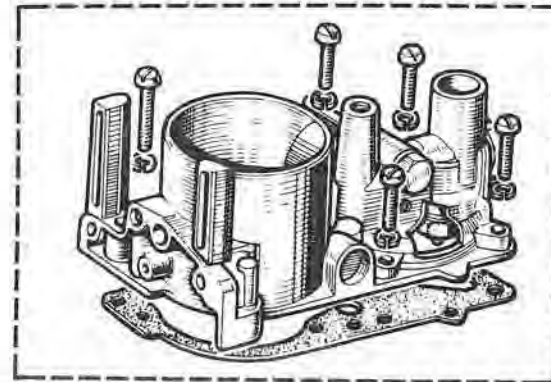

08 55 511 700

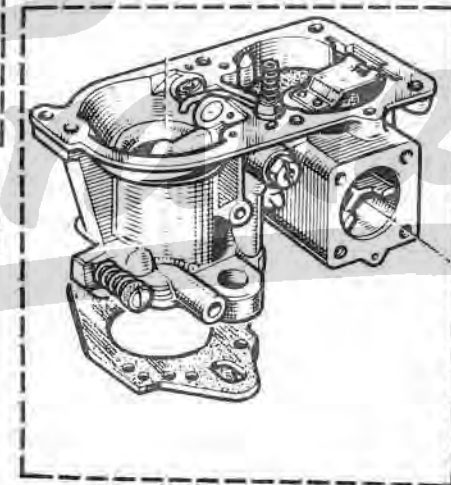

08 54 973 600

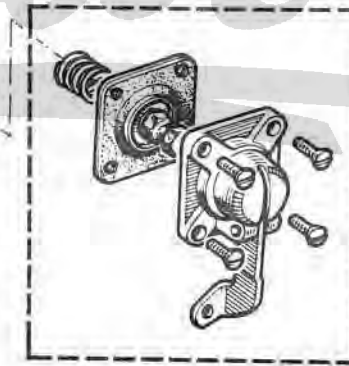

(a) 08 54 867 400

311
396

(b) 08 54 912 500

311-1
396-1

(c) 08 55 682 300

339-1

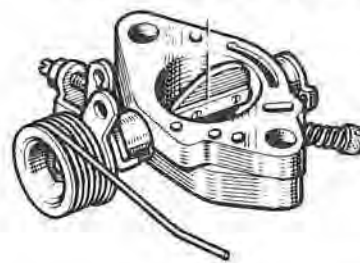

08 55 511 500 (a)

08 55 512 000 (b) (c)

311
396
311-1
339-1
396-1

(a)	/ 10/11/12/13/14/15/18/20/21/22/24/27/28/29/30/40/41/42/100/101/102/103 120/121/122/130/140/200/201/202/204/207/211/220/230/231/240/241/242
(b)	/ 70/80/81/84/88/89/700/800/801/807/810/811
(c)	/ 86/803



15.41.1

B P.R. 810

R 2134 |  /26/203
R 2135

15.41.1

B P.R. 810



- 8547299
- (A=21,5) 08 53 770 300
- 8552530
- 8537198
- 8537198
- (A=15,5) 08 54 971 500
- 8549719
- 8539277
- 8540467
- 8551897
- 8551896
- † 08 54 973 500
- 08 70 025 000
- (g) (a) † 08 55 254 100
- 08 02 613 500

- 8545223
- 8545224
- 08 54 971 500 (A=15,5)
- 8549713
- 8549714
- 8546252
- 8545224
- 8550643
- 8549716
- 8026149

8535044

8549729

8555118

8026132

{ 8557585 (e)
8549728 (f)

8539779

{ 77 01 000 980 (c)
8555116 (d)

8549739

8549737

8552544

1081 110452

8517023

8549738

8549742

8547418

8541416



8552543

8516978

8026133

8026132

8535823

- 8549733
- 8552539
- 8535823
- 8544215
- 8552532
- 8552533
- (c)  8550628
- (d)  8550632
- 8547270
- 8546254
- 8026127

(a) R 2134	10/11/12/13/14/15/18/20/21/22/24/27/28/29/30/40/41/42/70/80/81
	84/88/89/100/101/102/103/120/121/122/130/140/200/201/202/204/207
	211/220/230/231/240/241/242/700/800/801/807/810/811







15.41.2
B P.R. 810



15.41.2
B P.R. 810

			<u>?</u>	
(c)	<input type="checkbox"/> 311	<input type="checkbox"/> 396		
(d)	<input type="checkbox"/> 311-1	<input type="checkbox"/> 339-1	<input type="checkbox"/> 396-1	
(e)	<input type="checkbox"/> 339-1			
(f)	<input type="checkbox"/> 311-1	<input type="checkbox"/> 311	<input type="checkbox"/> 396-1	<input type="checkbox"/> 396
(g)	<input type="checkbox"/> 311	<input type="checkbox"/> 311-1	<input type="checkbox"/> (35)	<input type="checkbox"/> (35) <input type="checkbox"/> 08 70 535 100 -1-  15-45



to Franzose



15.42

B P.R. 810

R.2134 / 26/203
R.2135

15.42

B P.R. 810

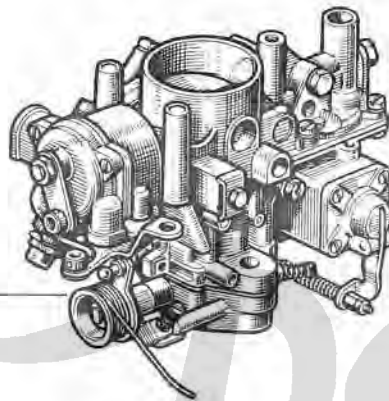

8556627

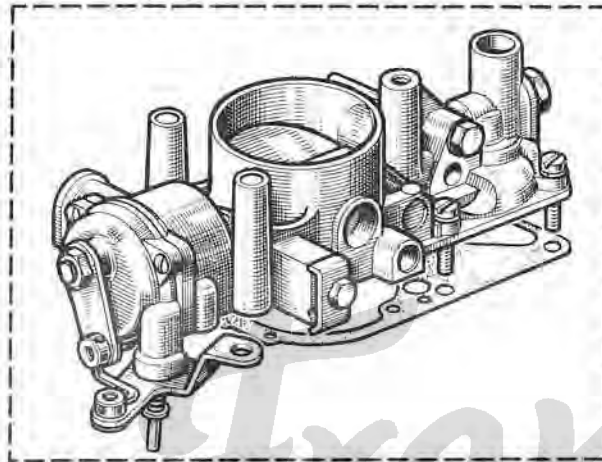

8700050

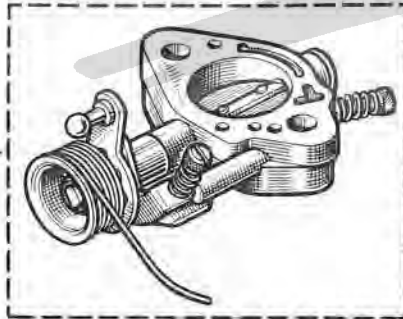

8700052

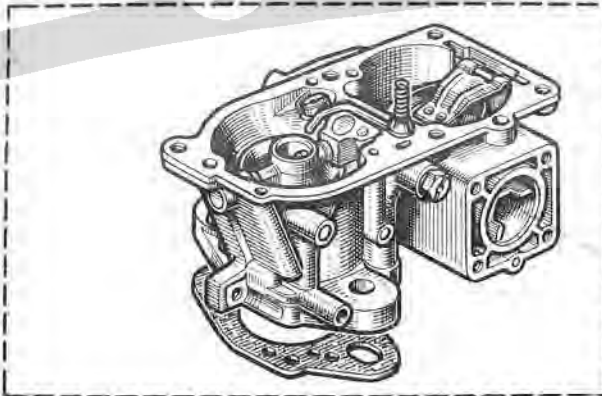

8700059

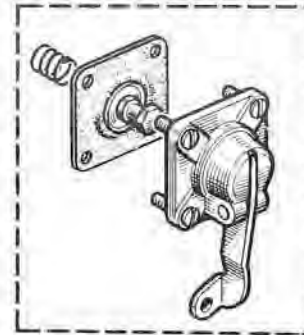

8549736

Der Franzose



15.43

B P.R. 810

R.2134 /
R.2135 / 26/203

15.43

B P.R. 810



8545223
(A=21.5) 08 53 770 300
(A=15.5) 08 54 971 500

8556907

8556908

8520227

8700051

8509674

+ 08 54 973 500
08 70 025 000

8026135

8552539

8549733

8535823

8700055

8700054

8026131

8026132

8700058

8544685

8700056

8700057

8547270

8546254

8026127

8545224

08 54 971 500 (A=15.5)

8549713

8549714

8546252

8545224

8550643

8026149

8509675

8549716

8535044

8549729

8700060

8516978

8700053

8552544

8549739

8549737

1081 110452

8517023

8549738

8547418

8541416

8549742

8552543

8539779

8535823

8026133

8026132

8547310

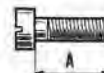



15.45
B P.R. 810



15.45
B P.R. 810

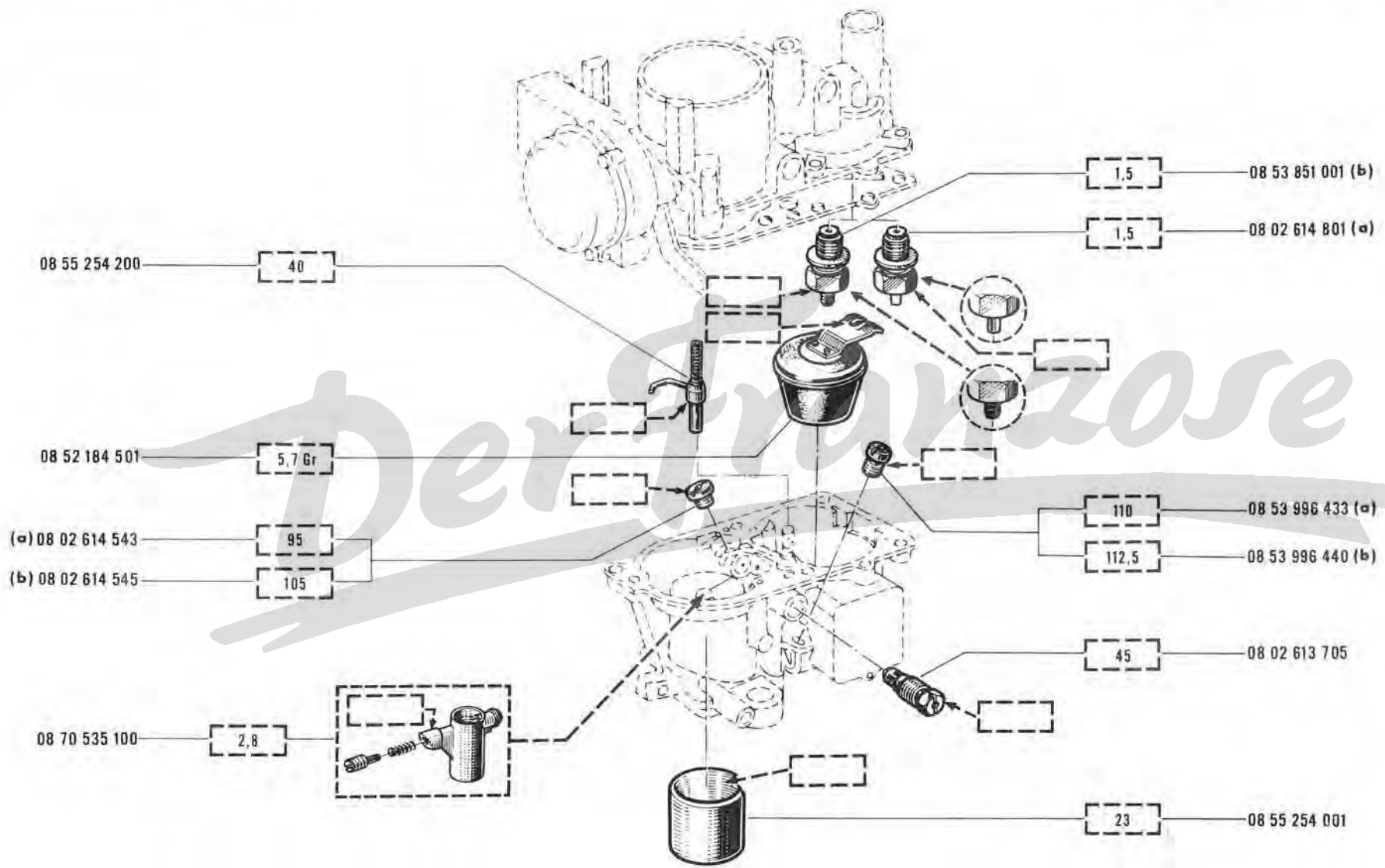

(a)	R 2134	} ☒ /26/203
	R 2135	
(b)	R 2134	/ 26/203
	R 2135	

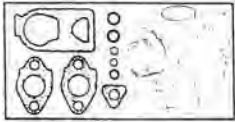

15.48
B P.R. 810

R 2134 } /26/203
R 2135 }

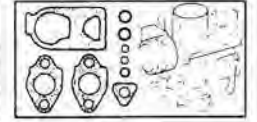

15.48
B P.R. 810

08 55 085 400

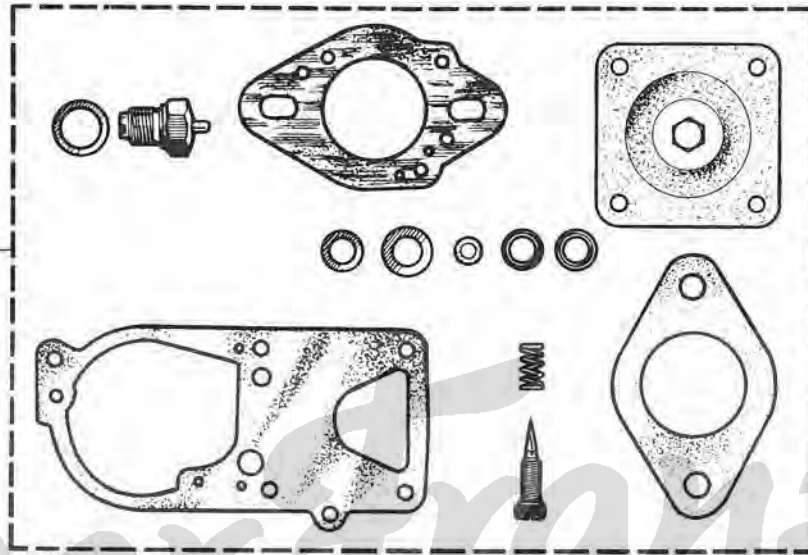

Der Franzose

08 55 085 500

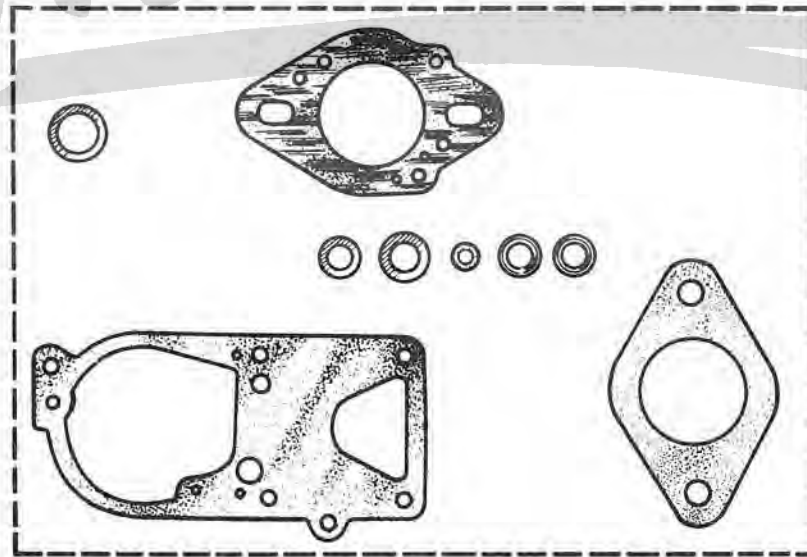

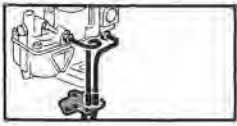

15. 70
B P.R. 810



15. 70
B P.R. 810

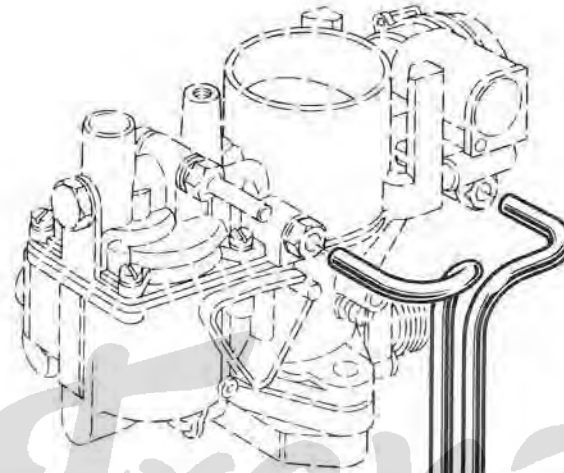

(a) 08 52 899 000

08 52 899 100 (a)

(b) 08 55 682 400

77 03 001 136

08 54 978 300 (a)

06 07 329 500

(a)	R 2134 R 2135	} 26/203
(b)	R 2134 R 2135	



15.75

B P.R. 810



07 06 241 602
10 81 310 852
06 07 059 202

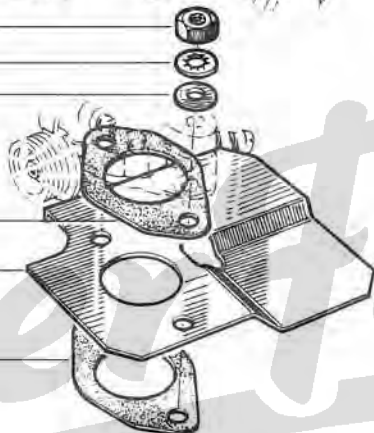

06 07 332 200
06 07 410 400
06 07 332 200

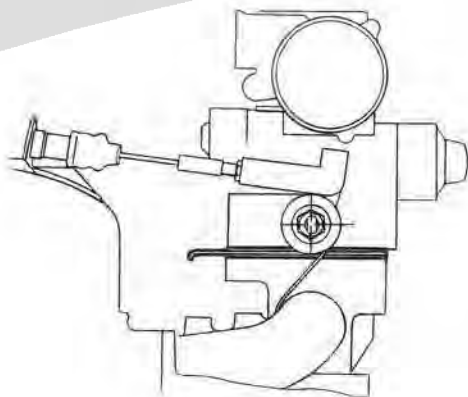

15.75

B P.R. 810



07 06 241 602
10 81 310 852
06 07 059 202
08 24 469 900
80 80 100 552
06 07 332 200
05 55 627 400

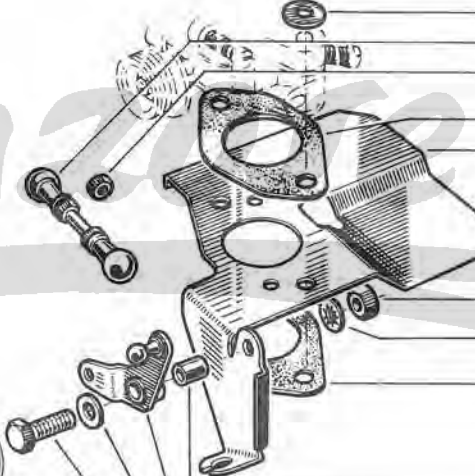

80 80 100 752
10 81 350 782
06 07 332 200

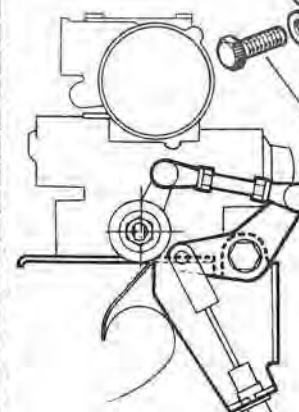

06 07 410 500
08 24 409 000
10 81 110 752
77 03 001 140

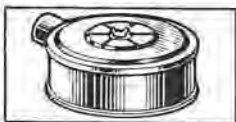

15.80

B P.R. 810

15.80

B P.R. 810



08 52 899 900

08 52 632 100

08 54 862 300

08 57 631 600

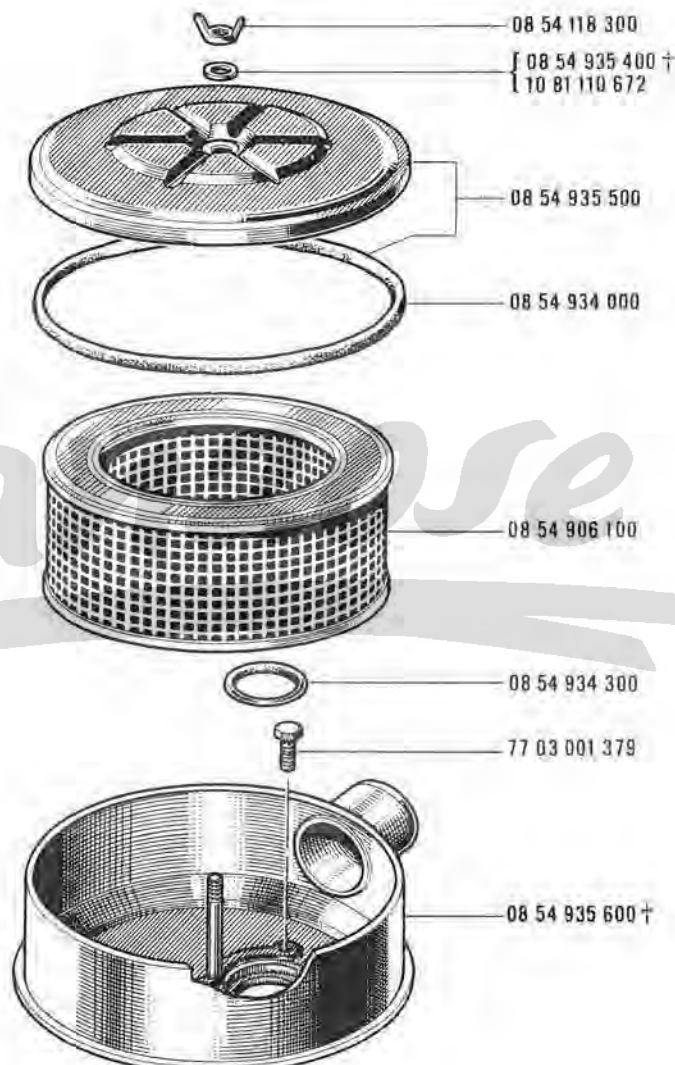
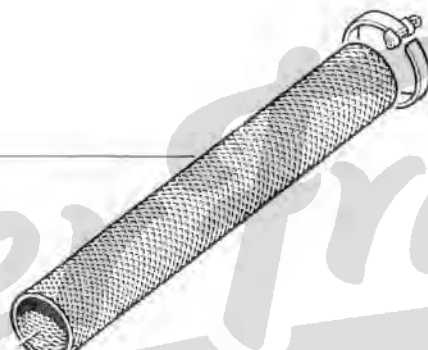

08 54 118 300

08 54 935 400 †

10 81 110 672

08 54 935 500

08 54 934 000

08 54 906 100

08 54 934 300

77 03 001 379

08 54 935 600 †

Devi Grause



16 .01

B P.R. 810

16 .01

B P.R. 810

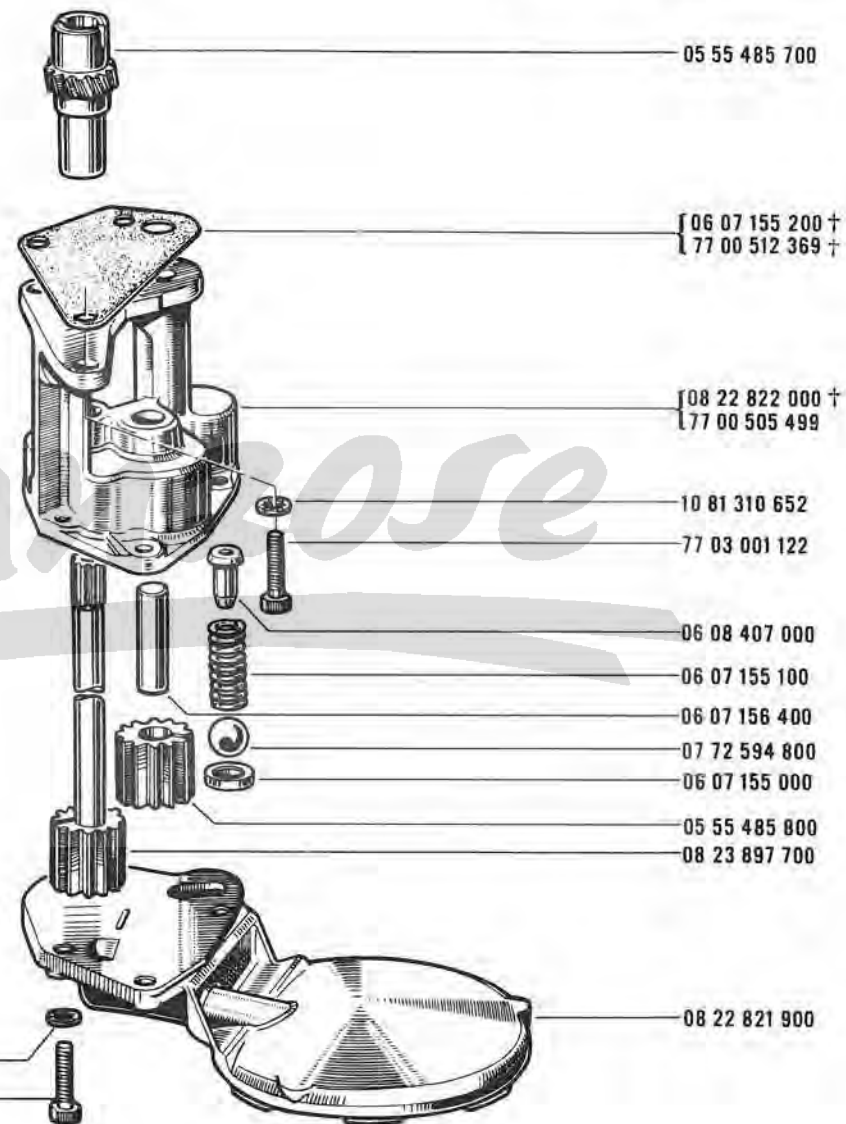
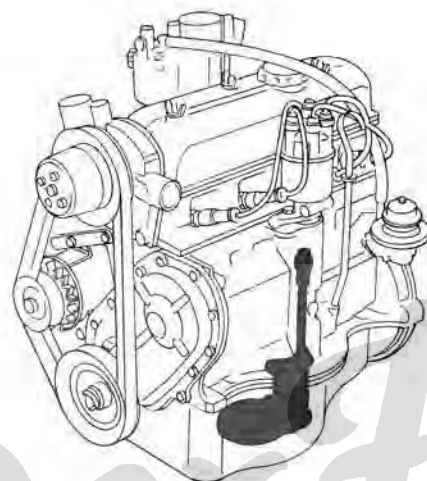

† 09 80 644 400
77 01 506 600

10 81 310 652
77 03 001 122

05 55 485 700

† 06 07 155 200
† 77 00 512 369

† 08 22 822 000
† 77 00 505 499

10 81 310 652

77 03 001 122

06 08 407 000

06 07 155 100

06 07 156 400

07 72 594 800

06 07 155 000

05 55 485 800

08 23 897 700

08 22 821 900

Derfranchise



16 .10

B P.R.810

16 .10

B P.R.810

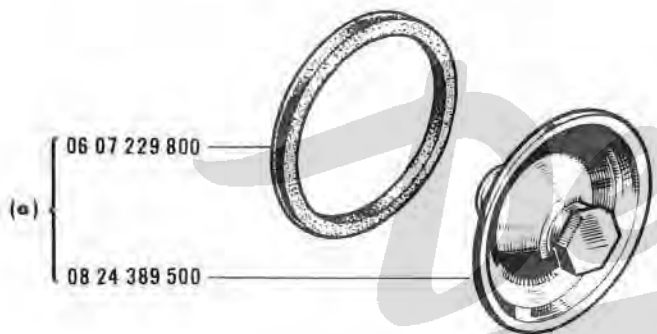
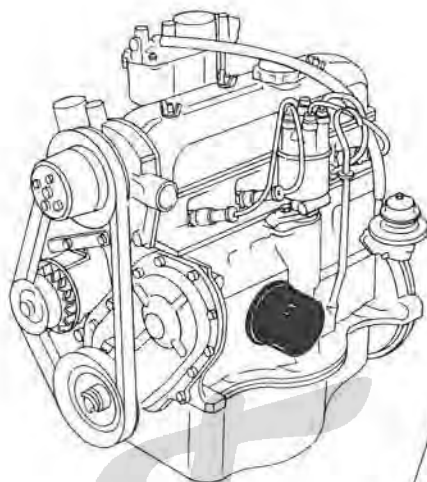

(a)

06 07 229 800

08 24 389 500

{ 06 07 148 500 † (b)
06 07 148 502 (c)

08 54 898 100 (b) [22]

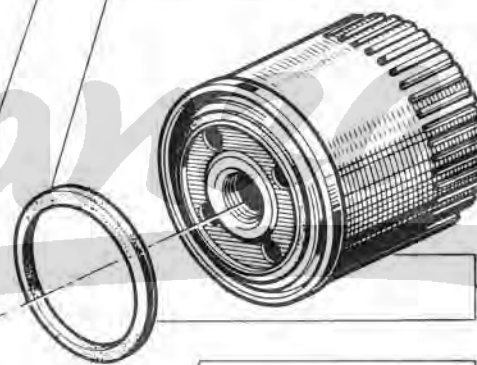

08 54 732 700 † (b) [22]

{ 08 54 897 900 † (b)
08 55 891 000 (c)

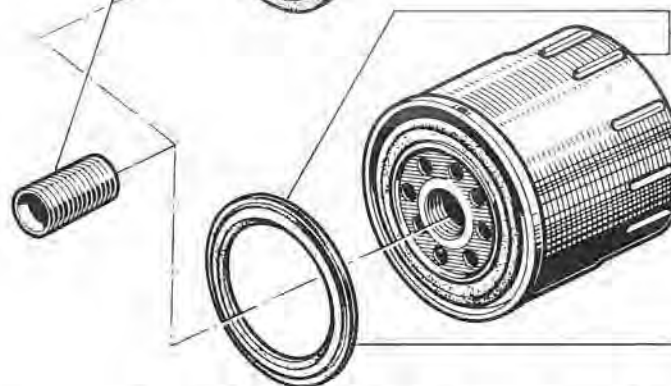

08 54 964 100 (c)

(a)	R 2134	10/11/12/13/14/15/18/27/29/30/40/42/70	: VEH n°	1 ⇨ VEH n° 11954
	R 2135	100/101/102/103/120/121/122 130/140/230/231/241/242/700		
(b)	R 2134	20/21/22/24/26/28/41/80/81/84/86/88/89/200/201/202	: VEH n° 11955 ⇨ VEH n° ...	
	R 2135	203/204/207/211/220/240/800/801/803/807/810/811		

(c)	R 2134	20/21/22/24/26/28/41/80/81/84/86/88/89	: VEH n° 11955 ⇨ VEH n° ...
	R 2135	200/201/202/203/204/207/211/220/240 800/801/803/807/810/811 100/101/102/103/120/121/122 130/140/230/231/241/242/700	

[22] 1 ⇨ 02.1966



17 . 01

B P.R.810

17 . 01

B P.R.810

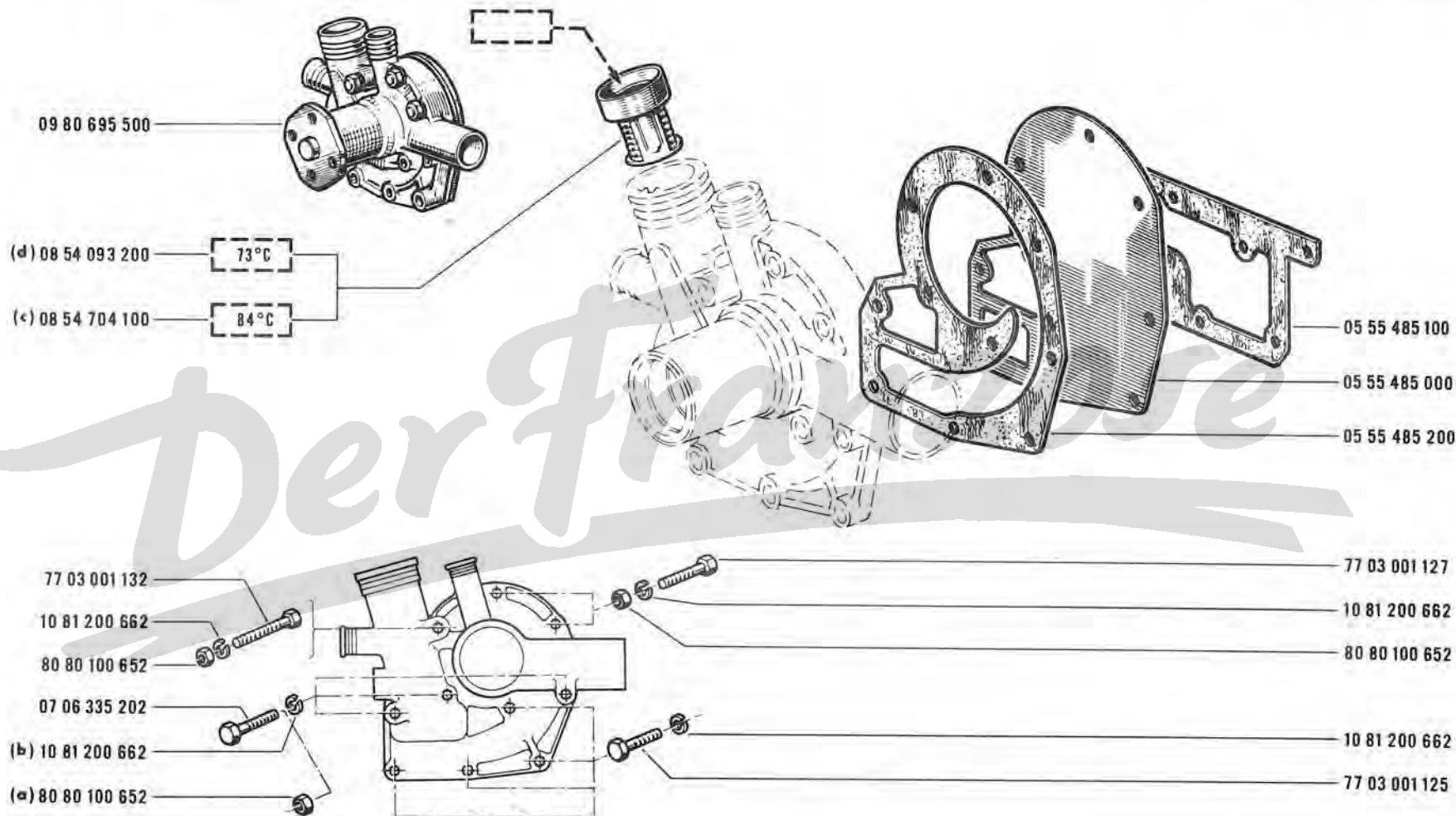

(a) MOT 688-01 n° 1 ⇨ MOT 688-01 n° 70756

(b) MOT 688-01 n° 70757 ⇨ MOT 688-01 n° ...

(c) R 2134 / 10/11/12/13/14/15/18/27/29/30/40/41/42/70/100/101/102
R 2135 / 103/120/121/122/130/140/230/231/240/241/242/700

(d) R 2134 / 20/21/22/24/26/28/80/81/84/86/88/89/200/201
R 2135 / 202/203/204/207/211/220/800/801/803/807/810/811



17 .50

A P.R. 810



17 .50

A P.R. 810

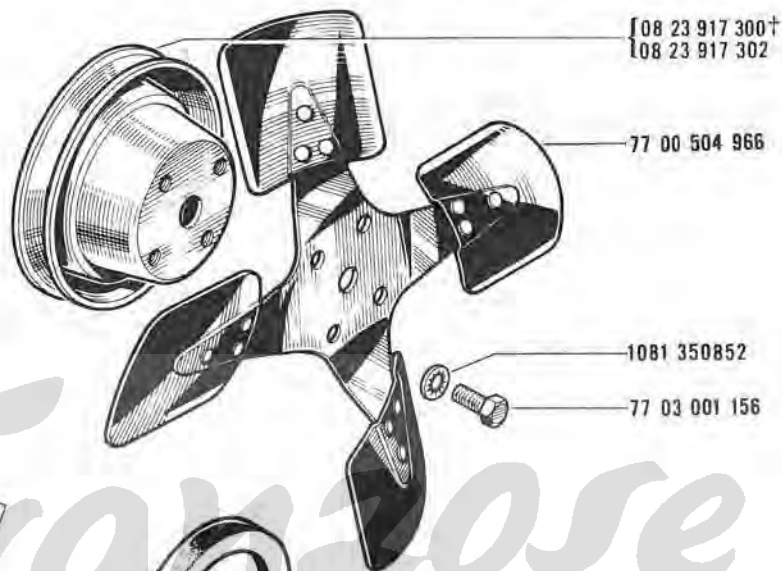
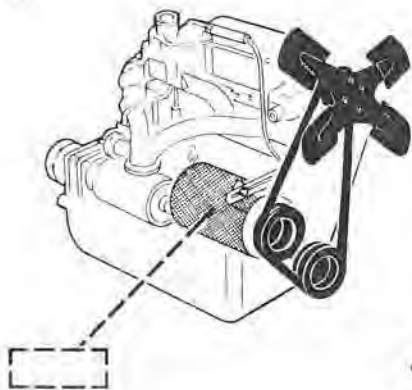

{ 08 23 917 300†
08 23 917 302

77 00 504 966

1081 350852

77 03 001 156

(1)(a) 08 54 887 700

(2)(b) 08 55 311 600

{ 08 54 679 600 (a)
08 55 242 700 (b)

† 08 54 887 600

08 70 549 400

08 70 549 300

(30) 08 70 549 100

{ 08 23 896 300†
08 23 896 302

(a)	R 2134	/ 10/11/12/13/14/15/18/20/21/22/24/26/27/28/29/70/80/81/84
	R 2135	86/88/89/100/101/102/103/120/121/122/130/200/201/202/203
		204/207/211/220/230/231/700/800/801/803/807/810/811
(b)	R 2134, R 2135	/ 30/40/41/42/140/240/241/242
(c)	R 2134, R 2135	/ 10/11/12/13/14/15/100/101/102/103/120/121/122

(30) VEH n° 1 ⇨ 1.10.1965
 Δ 08 70 549 300 -1-
 08 70 549 400 -1-

(1) ⚡	1272... 12 V...
(2) ⚡	LJ/GG 240/12/2400AR/21MR
(3) ⚡	... G 10C 58 12V ..

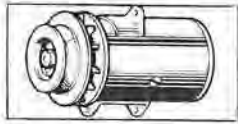

18.10
B P.R.810

R.2134
R.2135

10/11/12/13/14/15/18/20/21/22/24/26/27/28/29/70
80/81/84/86/88/89/100/101/102/103/120/121/122/130/200/201
202/203/204/207/211/220/230/231/700/800/801/803/807/810/811

18.10
B P.R.810

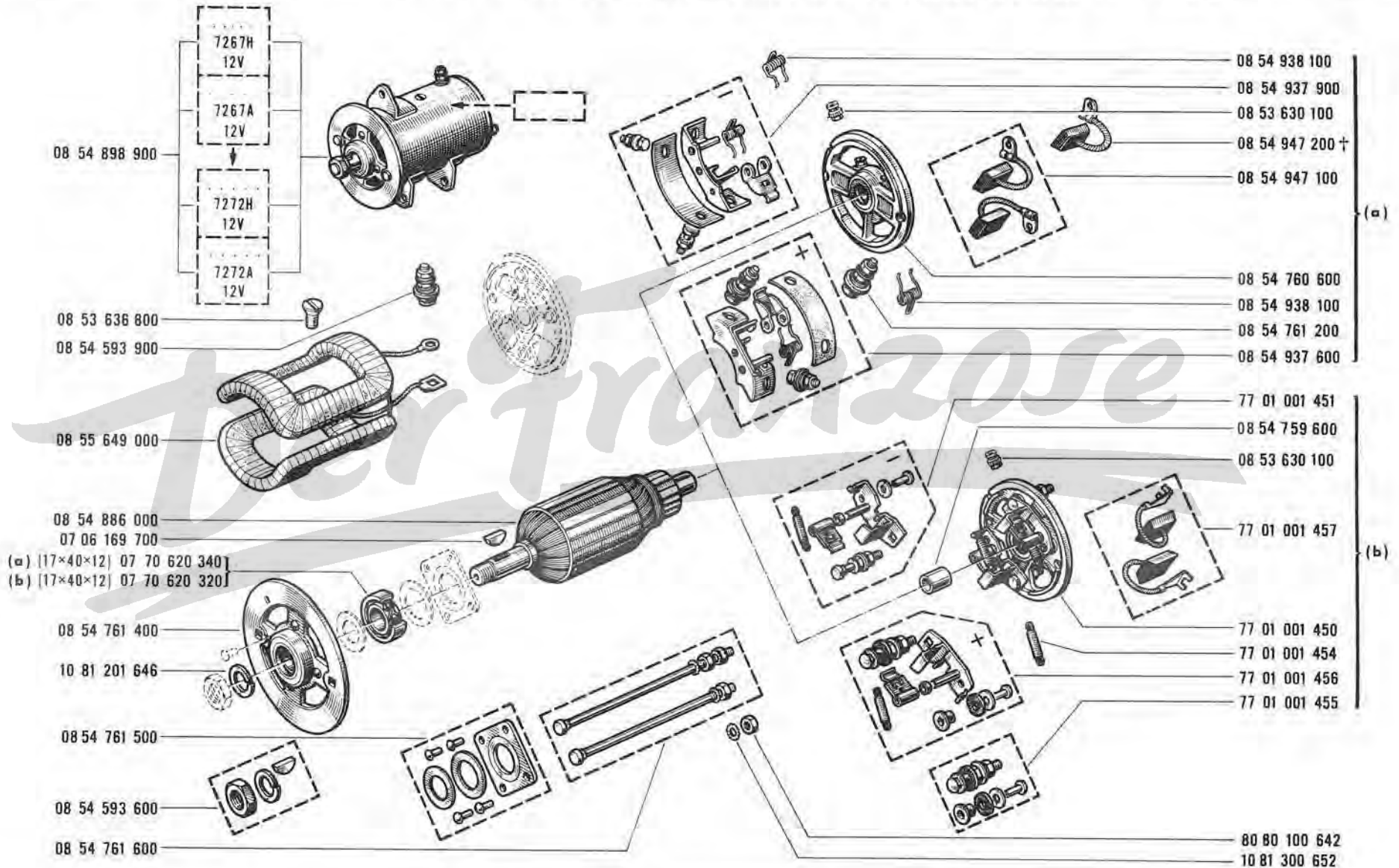
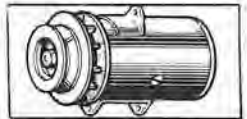

(a)	<input checked="" type="checkbox"/>	7267 H	7272 H
(b)	<input checked="" type="checkbox"/>	7267 A	7272 A

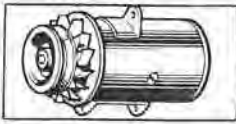

18.13

B P.R. 810

R.2134 / 10/11/12/13/14/15/100/101/102/103/120/121/122
R.2135

18.13

B P.R. 810

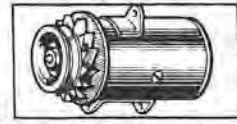

08 54 904 100

G 10C 14 12V

77 01 003 729

G 10C 58 12V

(a) † 08 55 510 900

08 54 701 800

08 54 861 200

10 81 301 652

08 54 861 300

80 80 100 642

80 70 040 082

10 81 300 452

08 54 914 700

08 54 860 800

08 54 701 100

08 54 860 700

08 54 860 900† (a)

08 70 293 500 (a)

77 01 003 876 (b)

08 54 701 200

08 54 701 300

08 54 701 700

08 54 860 600

08 54 700 600

08 54 700 700

(a) G 10C14 12V

(b) G 10C 58 12V

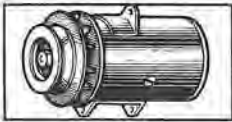

18.16

B P.R. 810

R 2134 / 30/40/41/42/140/240/241/242
R 2135

18.16

B P.R. 810

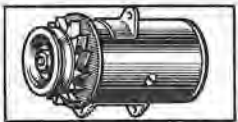

08 54 962 000

LI/GG
240/12/2400 AR/21MR

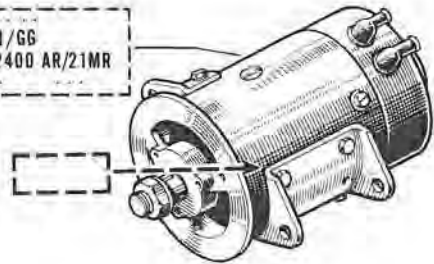

08 55 308 400
08 55 308 300
08 55 308 100

08 55 308 900
†08 55 308 800
08 55 310 700
(15×35×11) 08 55 310 500
08 55 310 400
08 55 310 300

†08 55 309 100
10 81 200 446
08 55 309 200

08 55 308 000

08 55 308 700
08 55 308 600
08 55 308 500

08 55 308 200
08 55 309 000

†08 55 309 100
10 81 200 446

08 55 308 100
08 55 528 100

08 55 307 900

08 55 294 300
08 55 307 700

08 55 307 600
08 55 307 500

08 55 307 400
08 55 307 200

08 55 307 300
08 70 281 900

08 55 307 800
08 55 307 700

08 55 311 000

08 55 311 200
†08 55 311 100
10 81 200 446

08 55 309 300

†08 55 309 400
10 81 200 646

08 55 309 200
08 55 309 700

08 55 309 800
08 55 310 600

†08 55 309 100
10 81 200 446

08 55 309 900

(17×40×12) 08 55 310 000

08 55 310 100
08 55 310 200

08 55 309 500

08 55 310 800

08 55 310 900

08 55 309 600

08 55 311 500
†08 55 309 400
10 81 200 646

08 55 307 100
08 55 307 000

08 55 378 100
08 55 306 900

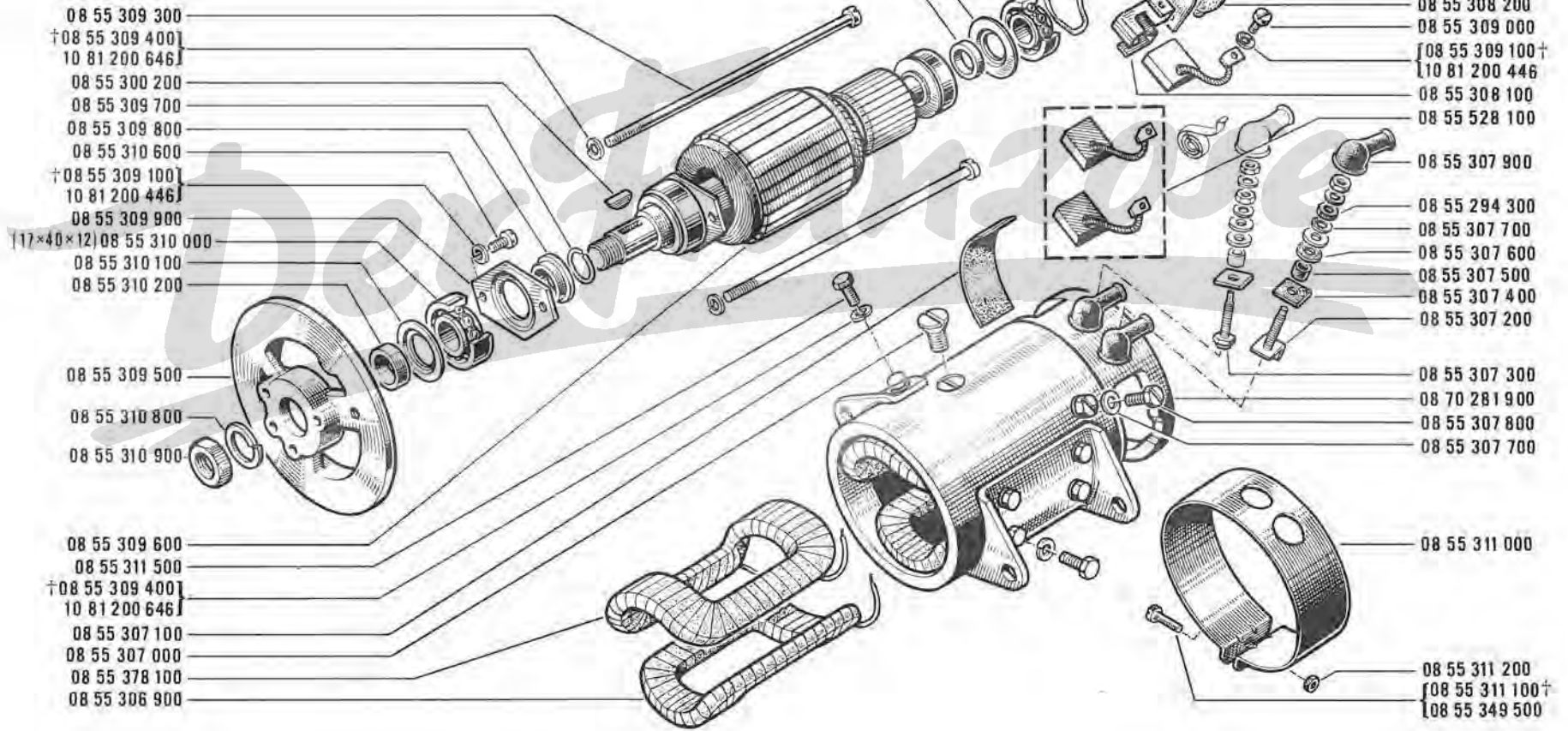

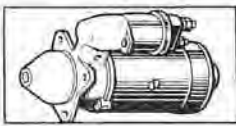

18.30.1

B P.R. 810

18.30.1

B P.R. 810

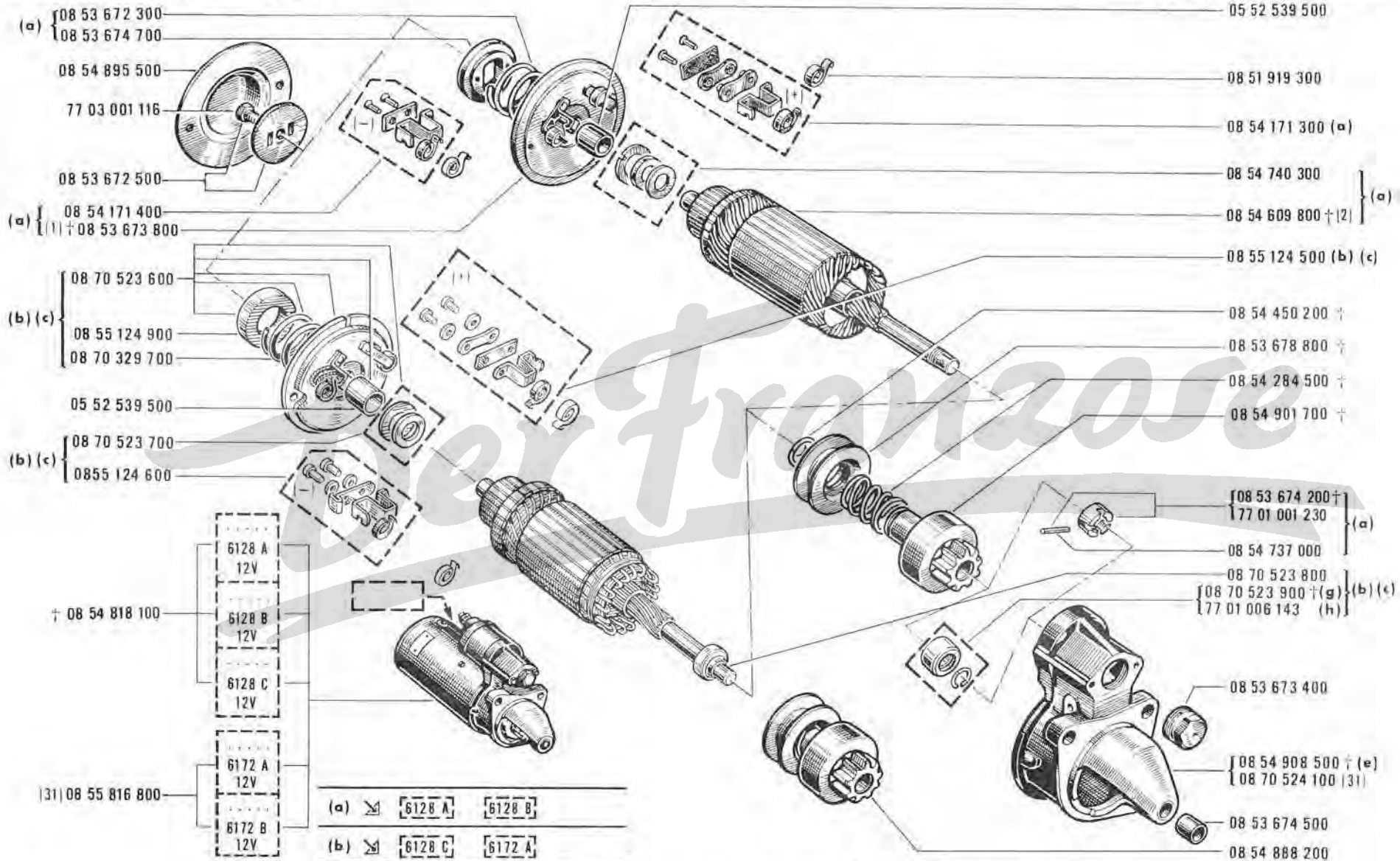
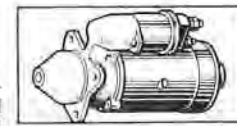

- 6128 A
12V
- 6128 B
12V
- 6128 C
12V
- 6172 A
12V
- 6172 B
12V

(a)	<input checked="" type="checkbox"/>	6128 A	6128 B	
(b)	<input checked="" type="checkbox"/>	6128 C	6172 A	
(c)	<input checked="" type="checkbox"/>	6172 B		
(e)	<input checked="" type="checkbox"/>	6128 A	6128 B	6128 C
(f)	<input checked="" type="checkbox"/>	6172 A	6172 B	

(g) VEH n°1 ⇨ 12.1968
 (h) 01.1969 ⇨ ...

(1) 08 70 523 600 -I-
 (2) 08 70 523 800 -I-
 (31) 06 08 420 300 -I-

(31) 08 55 816 800

05 52 539 500

08 51 919 300

08 54 171 300 (a)

08 54 740 300

08 54 609 800 † (2) (a)

08 55 124 500 (b) (c)

08 54 450 200 †

08 53 678 800 †

08 54 284 500 †

08 54 901 700 †

08 53 674 200 †
77 01 001 230 (a)

08 54 737 000

08 70 523 800
08 70 523 900 † (g) (b) (c)
77 01 006 143 (h)

08 53 673 400

08 54 908 500 † (e)
08 70 524 100 (31)

08 53 674 500

08 54 888 200

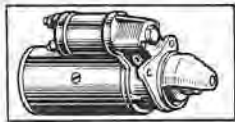

18.30.2

B P.R.810

- (f) 80 80 100 852
- (e) 80 80 160 852
- (e) 08 54 197 700
- (f) 08 70 085 700

- 80 80 100 542
- 10 81 200 546
- 10 81 110 552
- (f) 08 70 524 200
- (e) 77 01 006 407

- † 08 54 188 900
- † 08 54 189 100
- 08 54 775 100

- (a) 08 54 281 200
- (b) 08 70 523 500
- (c) 77 01 001 476

80 80 100 542

10 81 200 562

- (e) 08 54 281 500
- (f) 08 70 524 000

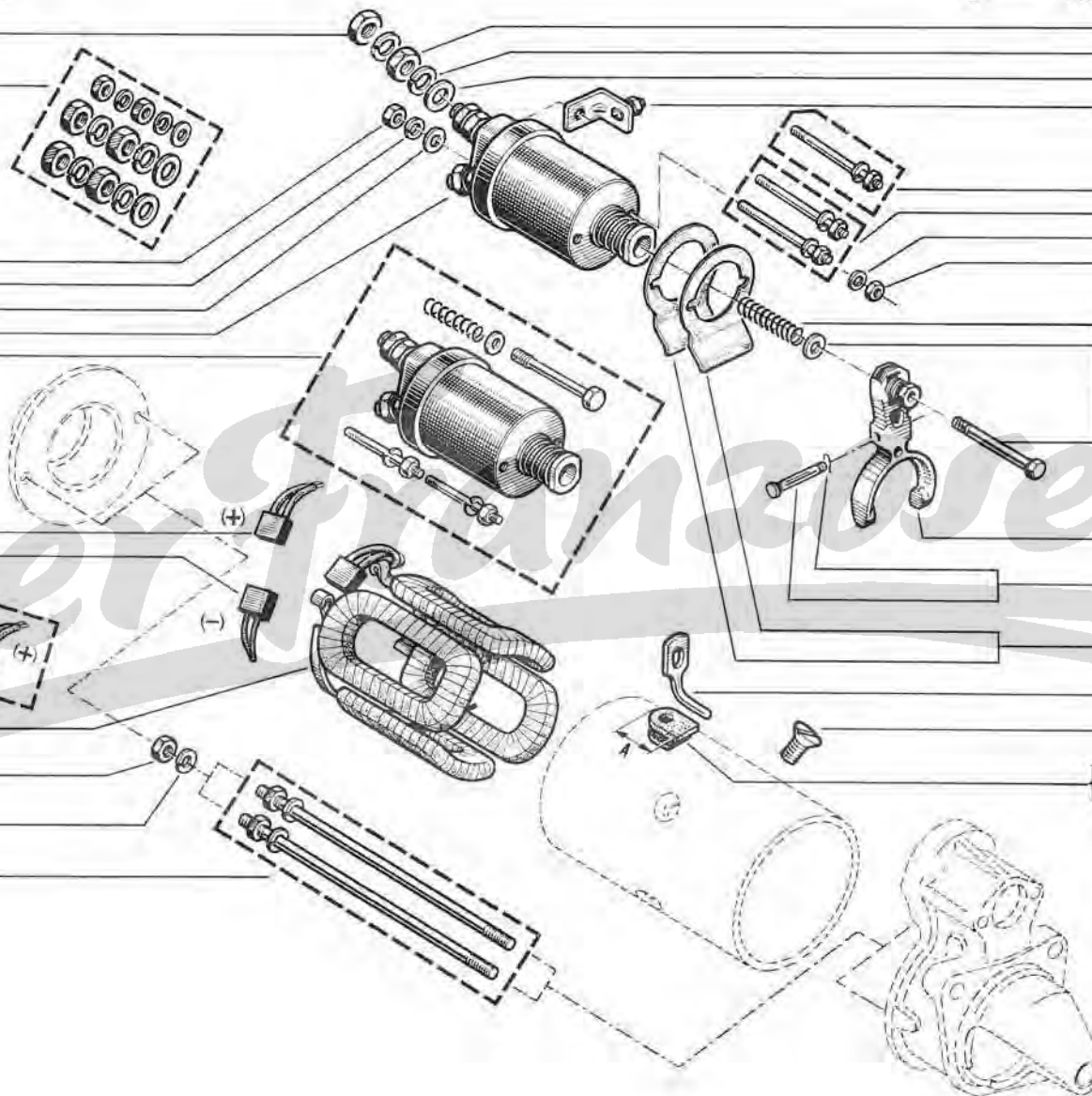

18.30.2

B P.R.810

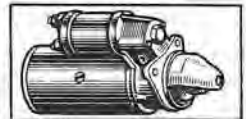

- 80 80 100 842
- 10 81 200 842
- 10 81 110 852
- [08 54 775 200 (e)
- [08 70 575 200 (f)

- 08 54 172 000 (e)
- 08 70 085 600 (f)
- 10 81 200 462
- 80 80 100 442

- [08 54 251 200 (e)
- [08 70 085 800 (f)

08 53 674 300

08 54 171 600

08 54 281 700

08 54 554 600

08 54 171 200

- [08 54 554 700 (A=18) (a) (b)
- [77 01 001 475 (A=24,5) (c)

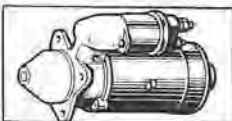

18.33

B P.R. 810

R.2134 / 10/11/12/13/14/15
R.2135 / 100/101/102/103/120/121/122

18.33

B P.R. 810

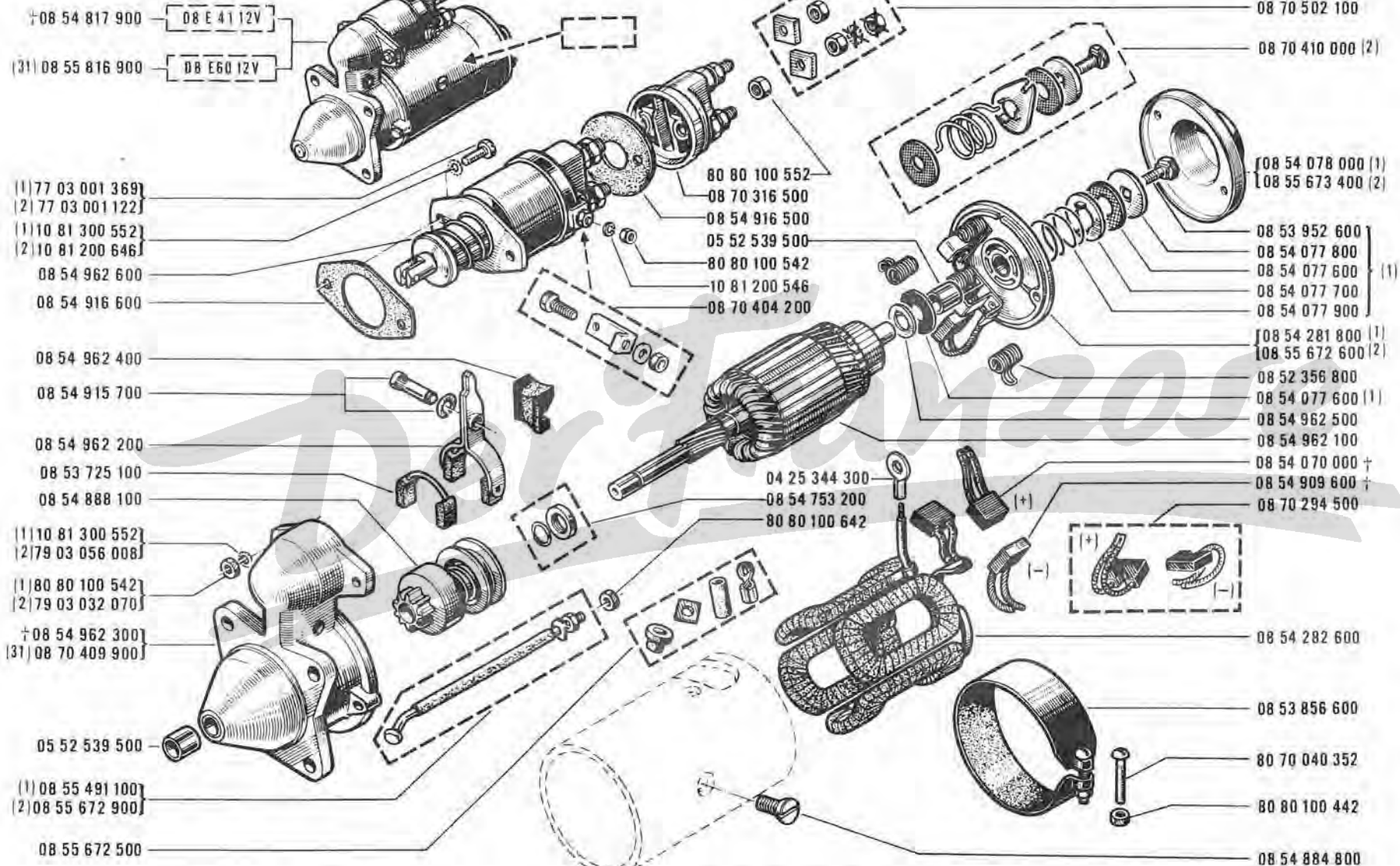
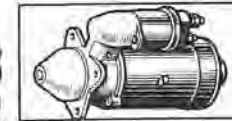

(1) 08 E 41 12V

(2) 08 E 60 12V

(31) 06 08 420 300 - 1-



18.40

B P.R. 810

18.40

B P.R. 810



- (a) 8700192
- (b) 8556673
- 8549942

- (5) † 8549048

- 8520362
- 8549943
- 8556672
- (a) 8021217
- (b) 8024540
- 8557120
- 1081 300452
- (a) 8021218
- (b) 8549436

8549941

8021207

- 8523050
- 8542205
- 8540638
- 8549430
- 8549431
- 8549432

(a) R 2134 / 10/11/12/13/14/15/18/70/100/101/102/103/120/121/122/130/700
 R 2135

(b) R 2134 / 20/21/22/24/26/27/28/29/30/40/41/42/80/81/84/86/88/89/140/200/201/202
 R 2135 / 203/204/207/211/220/230/231/240/241/242/800/801/803/807/810/811

- 8540633
- 8549009
- { 08 54 910 100 † } (a)
- { 77 01 000 998 } (a)
- { 08 54 943 800 } (b)

8549103

8549236

- { 08 54 910 200 † }
- { 08 55 667 900 }

8556688

8542657 (b)

1081 300452

8549439 (b)

8556684

8021206

8549001

8506675

8549007

8021203

- { 8549429 (a)
- { 8549437 (b)

{ 51 } † 77 00 518 534 -1-



18.43.1

B P.R. 810

18.43.1

B P.R. 810

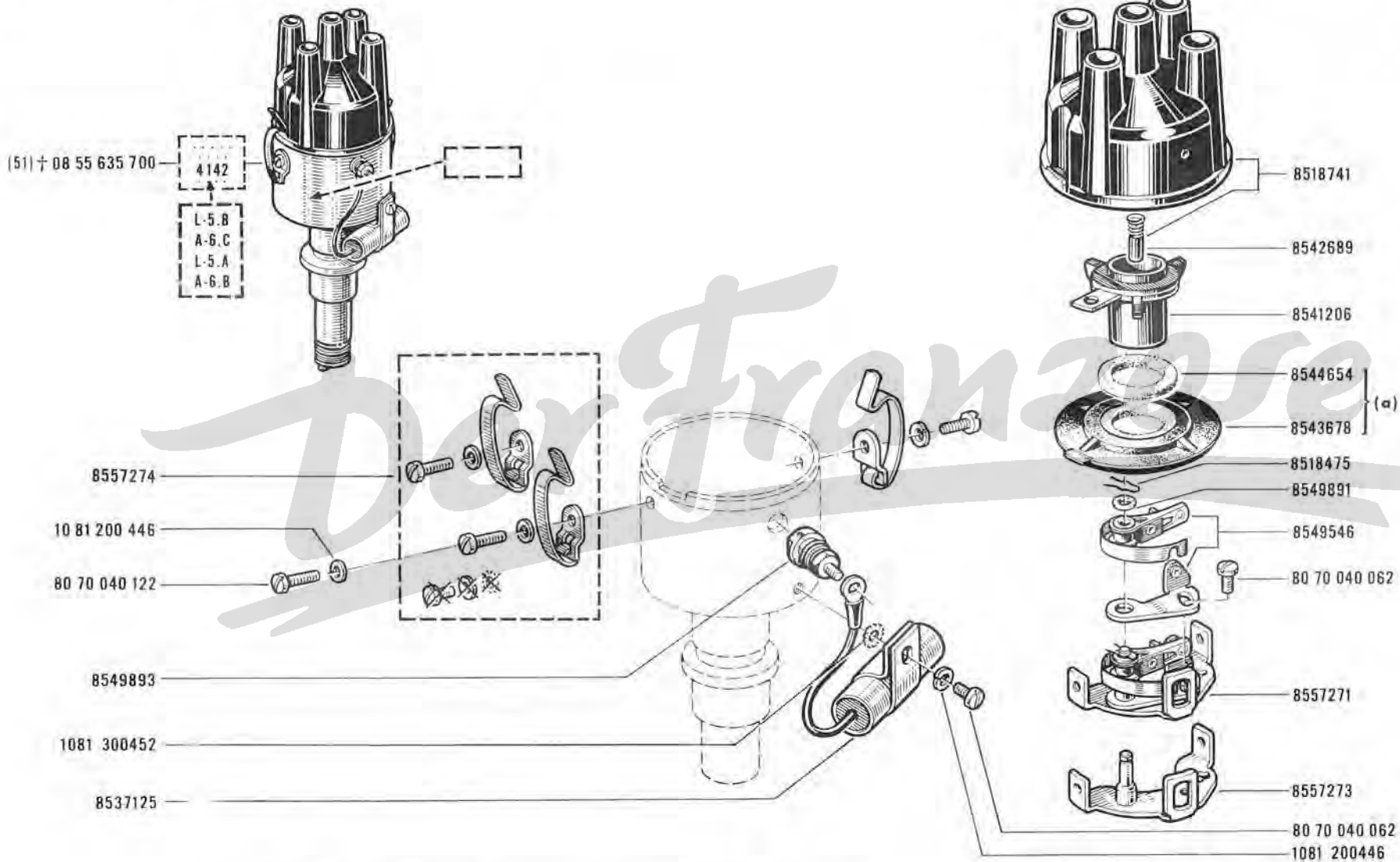

(a) R 21 34 / 20/21/22/24/26/27/28/29/30/40/41/42/80/81/84/86/88/89/140/200/201
 R 21 35 / 202/203/204/207/211/220/230/231/240/241/242/800/801/803/807/810/811

(51) † 77 00 518 534 -1-



18.43.2

B P.R. 810

18.43.2

B P.R. 810

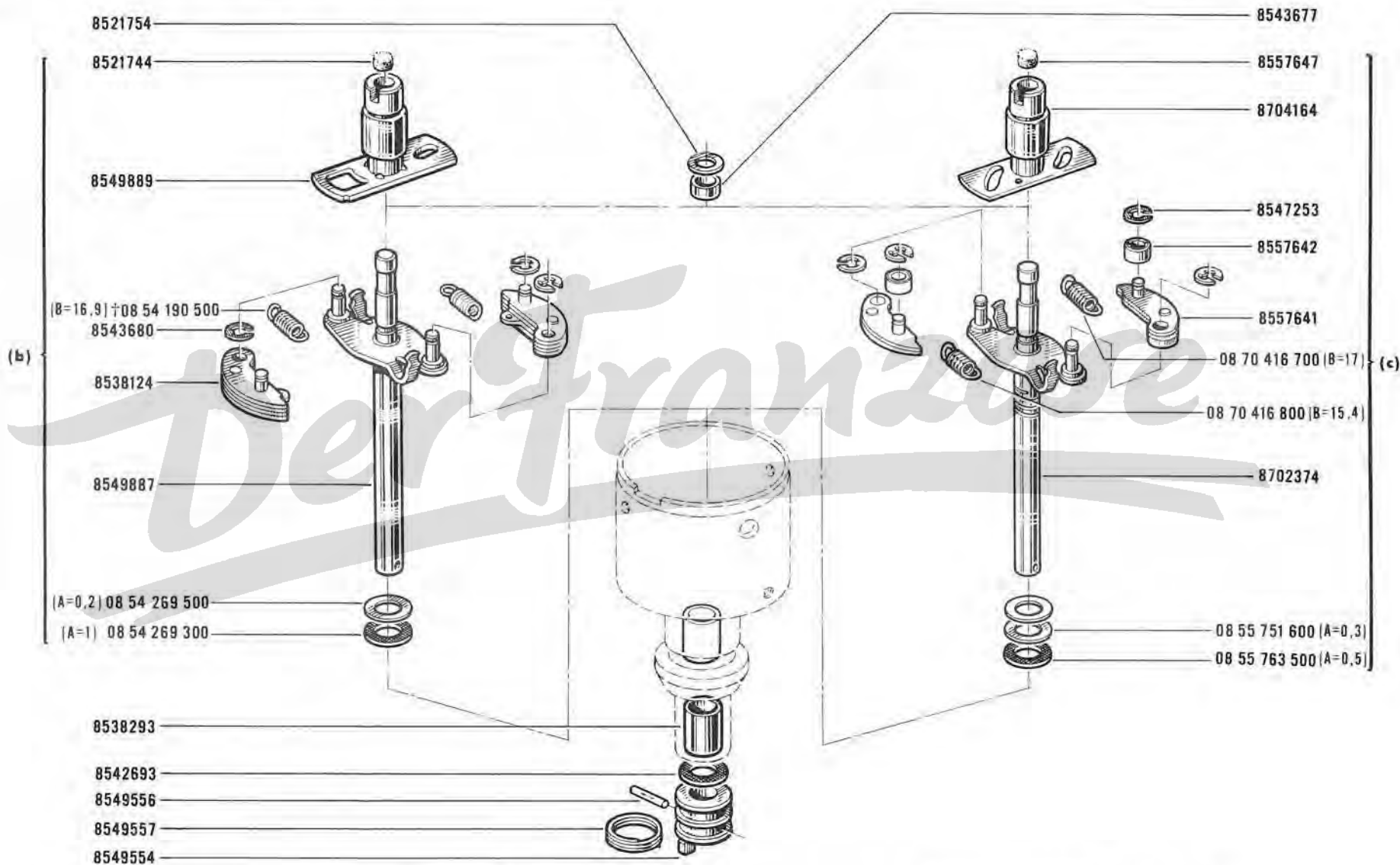

(b) ...	⇨	L.5.A
(c) A.6.B	⇨	...

(23) 06.01 ...



18.45

A P.R.810

18.45

A P.R.810



77 01 004 903

08 54 725 300

08 55 764 700



4261

4262

77 00 518 534

77 01 004 907

77 01 004 901

08 54 989 300

77 01 004 902

77 01 001 675

08 53 829 300

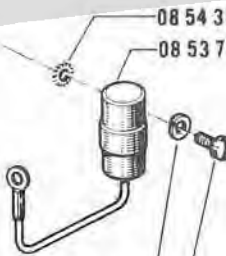
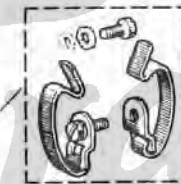

08 54 355 500

08 53 712 500

10 81 200 462

80 70 040 122



08 51 874 100

08 54 268 900

08 54 120 600

08 54 465 400

08 54 367 800

08 51 847 500

08 54 954 600

80 70 040 062

08 55 727 100

08 55 727 300

77 01 004 900



(a) 4262



18.60

B P.R. 810

18.60

B P.R. 810



06 06 715 000

08 54 051 700

- (a) {
- † 08 55 535 500 L 85
 - 08 55 836 400 L 87 Y D, G
 - 08 51 798 700 36
 - 08 54 407 100 44 F

04 25 293 300

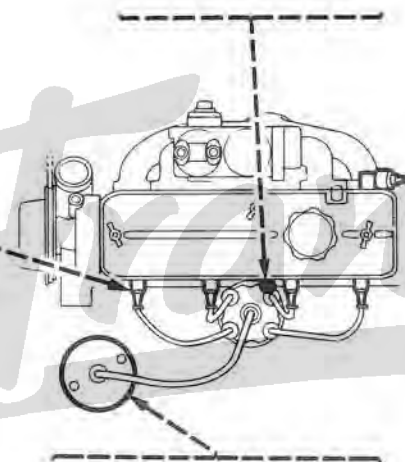
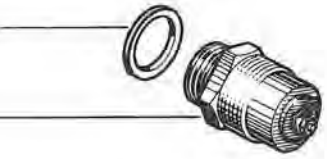

- 77 03 001 125
- 10 81 200 662
- 10 81 110 652
- 06 07 528 400 †
- 06 07 528 402 †
- 06 07 528 407
- 08 55 493 500

77 00 505 812

10 81 200 862

77 03 001 158

(c)

10 81 350 752

80 80 100 752

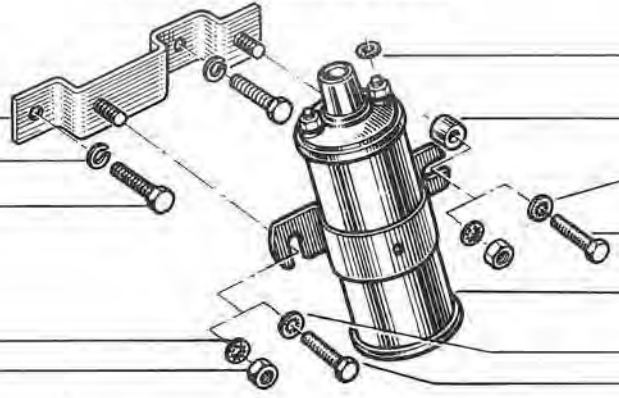

10 81 300 552

06 08 073 400

10 81 350 672 (b)

77 03 001 123

08 54 269 800

08 54 337 700

10 81 350 852 (b)

77 03 001 158

(a) R.2134 / 10/100
 R.2135

(b) MOT 688-01 n° 1 ⇨ MOT 688-01 n° 141416

(c) MOT 688-01 n° 141417 ⇨ MOT 688-01 n° ...

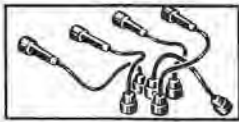

18.70
B P.R. 810

18.70
B P.R. 810

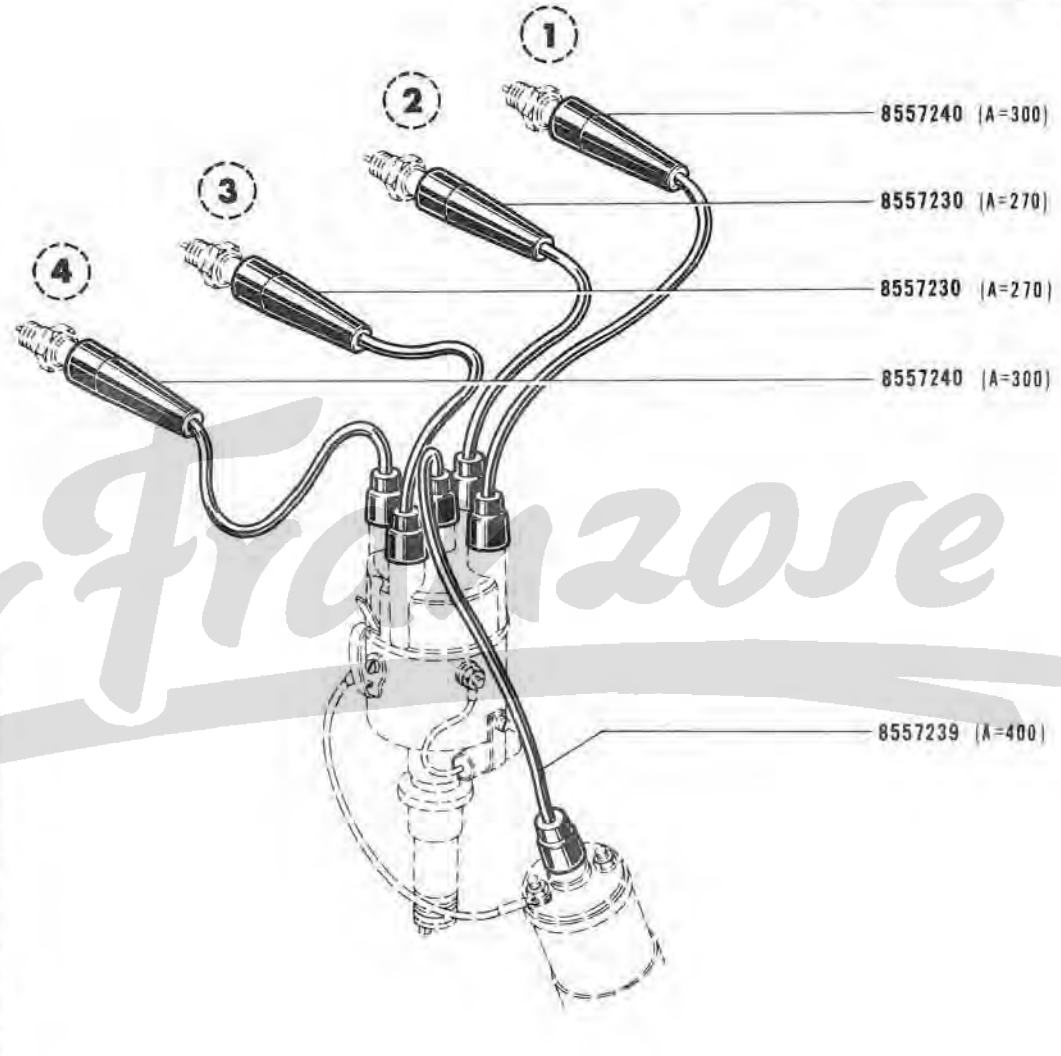
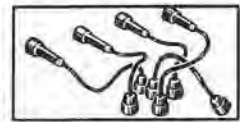

† 09 83 734 300
08 55 871 100



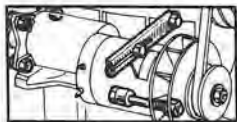

18.80

B P.R. 810

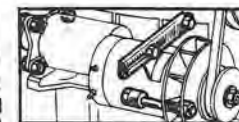

18.80

B P.R. 810

77 03 001 165

80 80 100 852

10 81 300 882

10 81 110 862

77 03 001 170

80 80 100 752

10 81 350 752

05 55 485 600

06 07 155 700

77 03 001 122

06 07 246 800

10 81 200 662

77 03 001 118

10 81 110 652

10 81 110 662

80 80 100 652

80 80 101 052

10 81 201 062

06 08 180 500

77 03 001 196

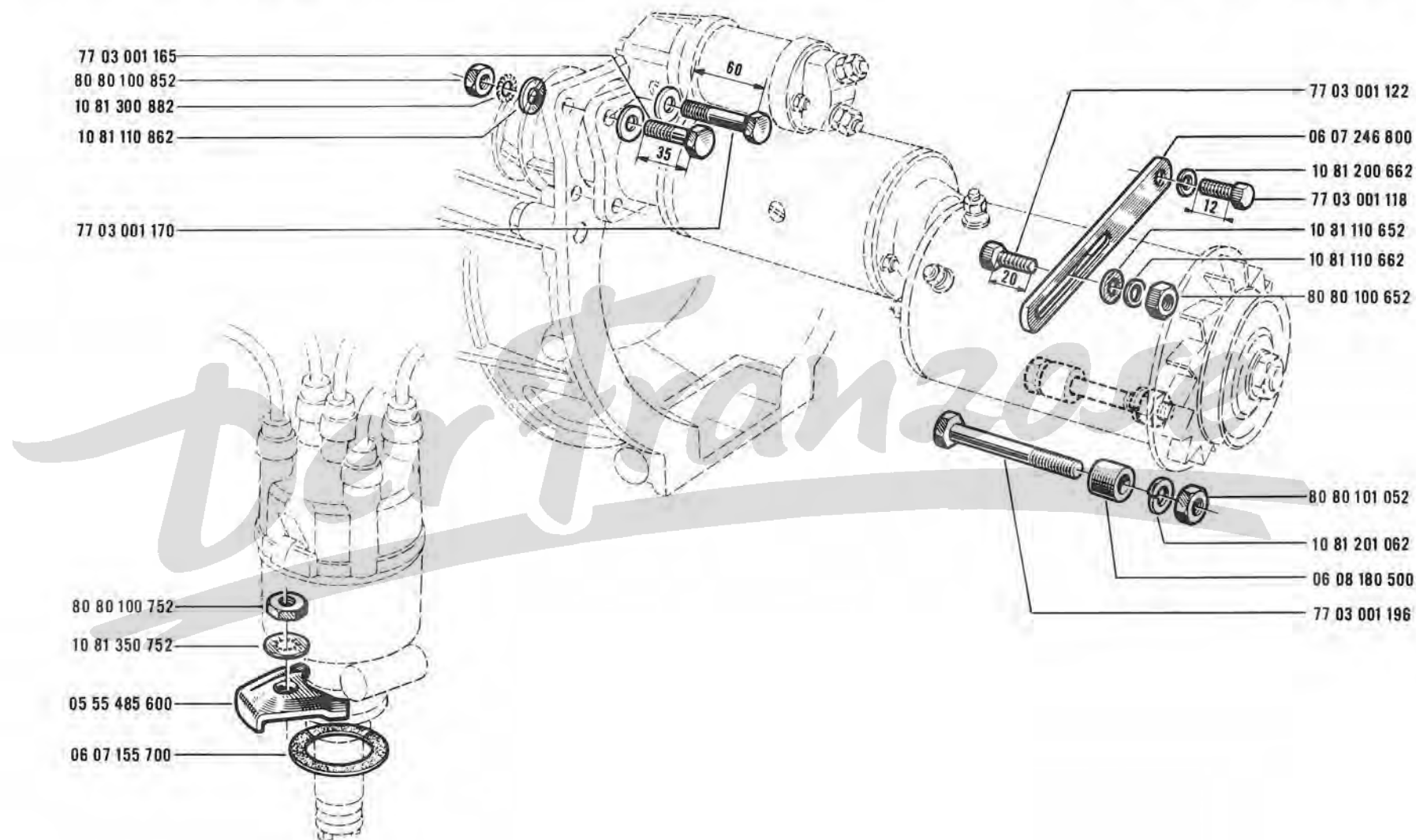



19.01

B P.R. 810

19.01

B P.R. 810

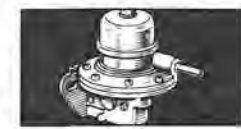

8544054

† 8513055

† 8513064

† 8513054

† 8513053

8515182

8550699

8547547

8547548

8513049

8513051

8027240

8547546

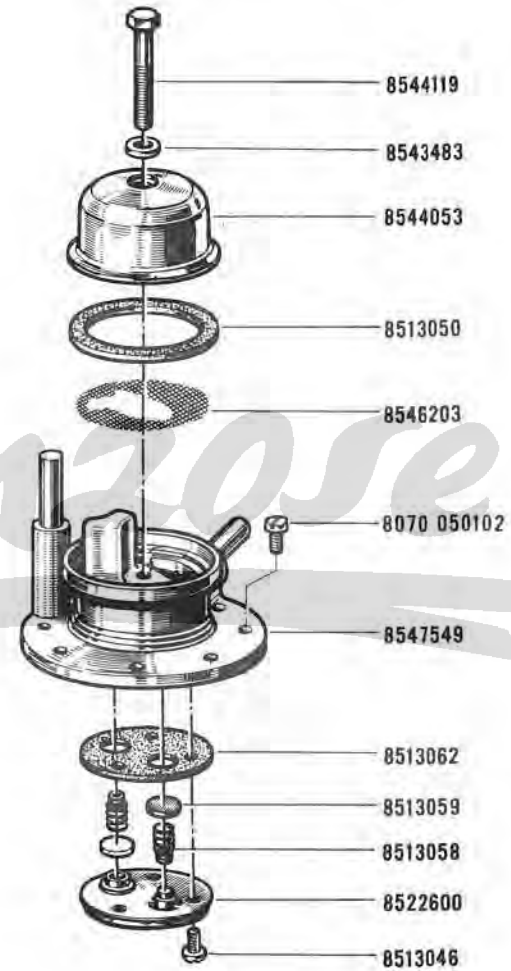
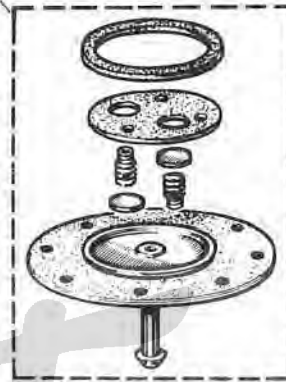
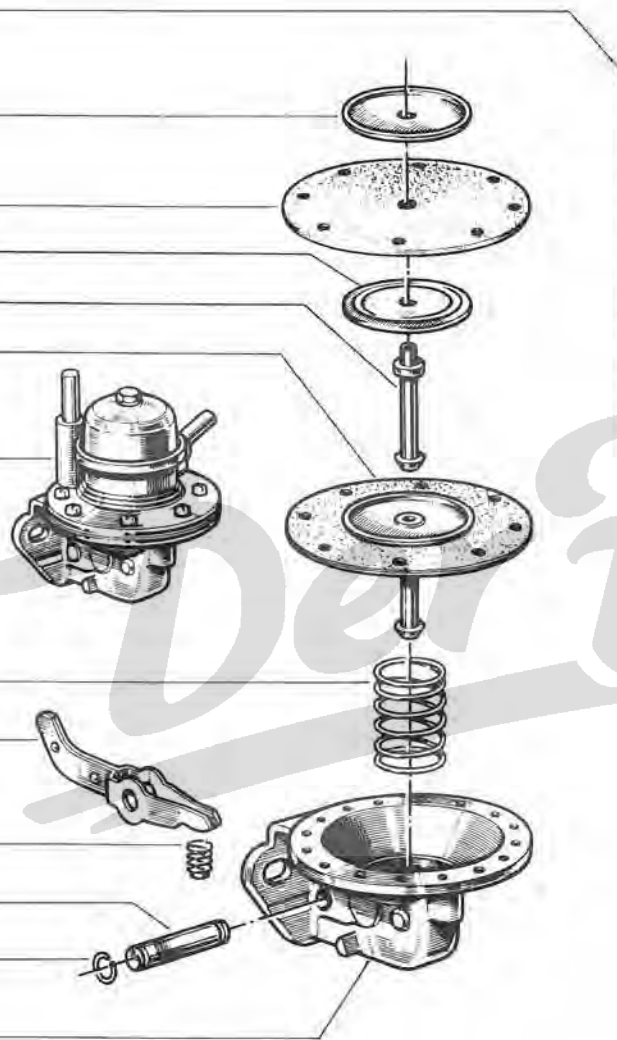

8544119

8543483

8544053

8513050

8546203

8070 050102

8547549

8513062

8513059

8513058

8522600

8513046

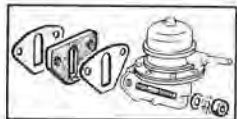

19 .20

B P.R. 810

19 .20

B P.R. 810

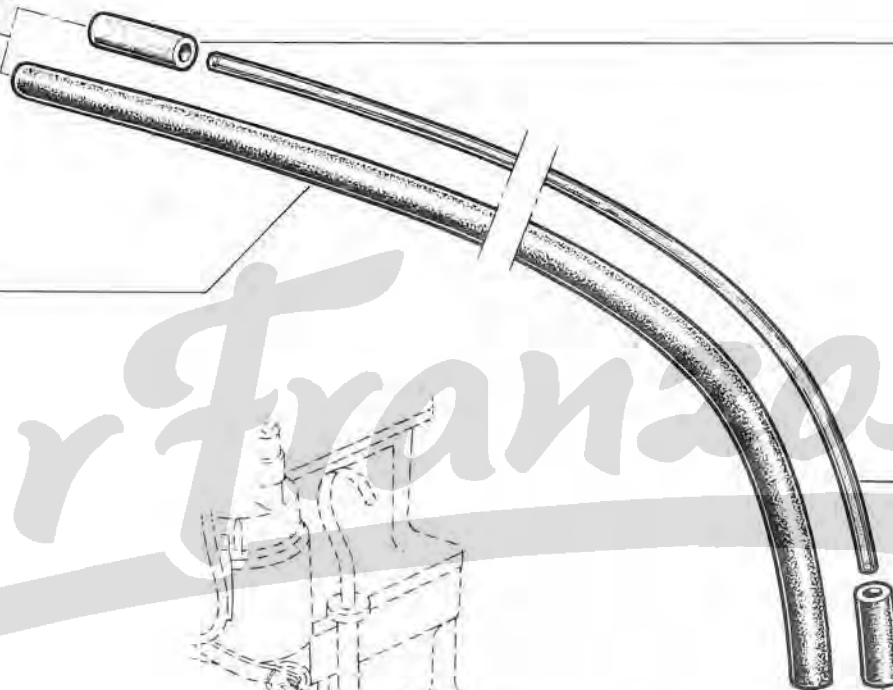
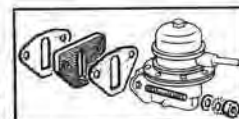

07 60 447 200(A=75) ✂ 1m

✂ 1m (A=450) 07 60 447 200

{ 07 50 760 900+
07 50 763 800 } (A=360) ✂ 1m

07 60 447 200(A=75) ✂ 1m

Der Franzose

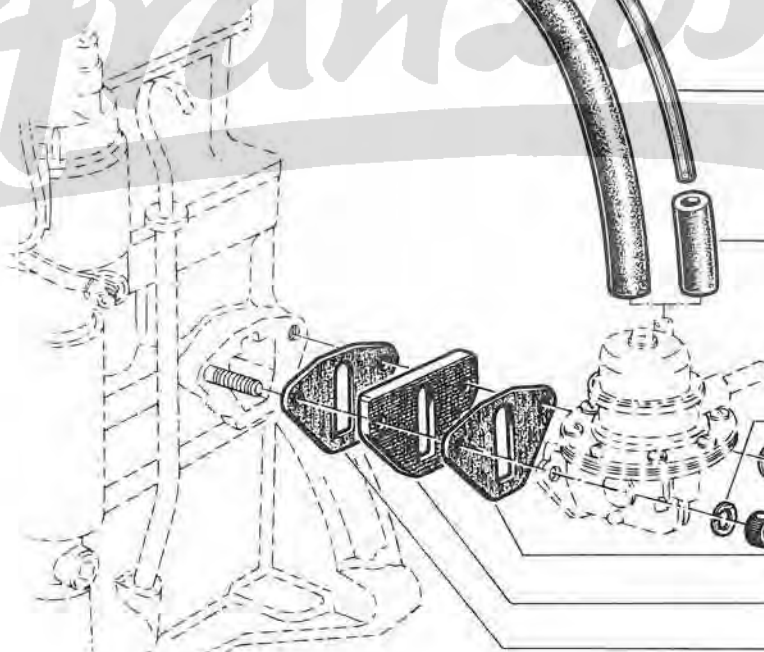

10 81 200 862

07 06 281 502

{ 07 06 316 102+
07 06 260 602

06 02 349 600+
08 57 704 100

{ 06 07 166 200+
06 08 008 900

06 02 349 600+
08 57 704 100

{ 06 07 166 200+
06 08 008 900

06 02 349 600+
08 57 704 100



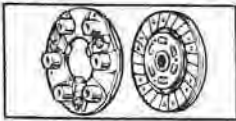

30.01
B P.R. 810

MOT 688-01 n°

1 ⇨ MOT 688-01 n° 79041

30.01
B P.R. 810

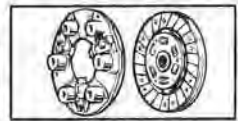

08 53 899 600

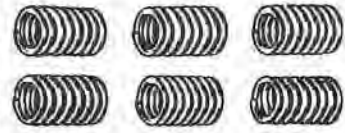
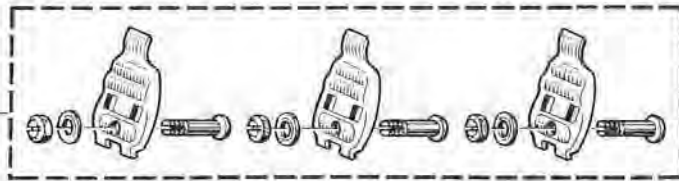

08 55 512 600

10 81 200 862

77 03 001 160



08 51 928 300

08 55 510 800
77 01 499 026



08 51 928 700

08 54 357 000

08 70 306 600 (A=3,8)

08 52 342 300

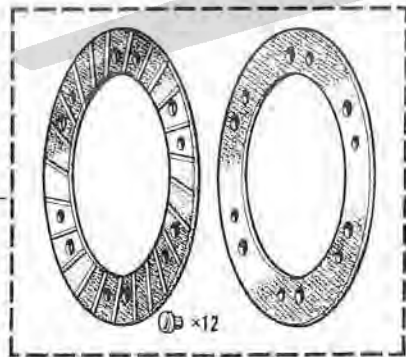

77 01 001 331

×12

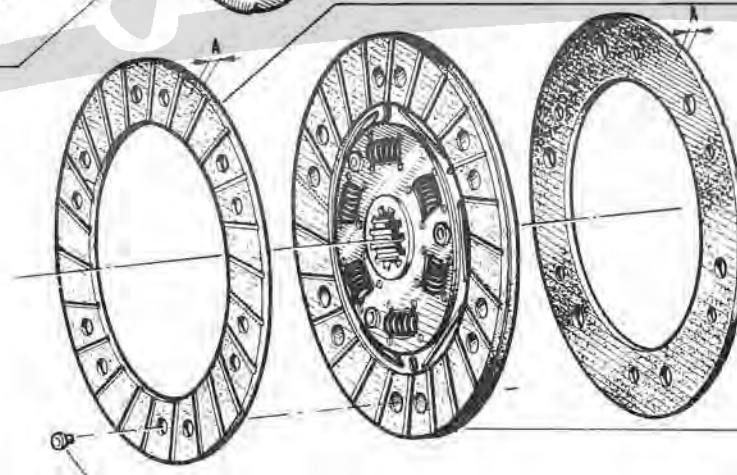

08 55 132 800 (A=3,5)

08 55 811 900
77 01 499 035

08 53 958 300



30.05

A P.R. 810

MOT 688-01 n° 79042 ⇨ MOT 688-01 n° . . .

30.05

A P.R. 810

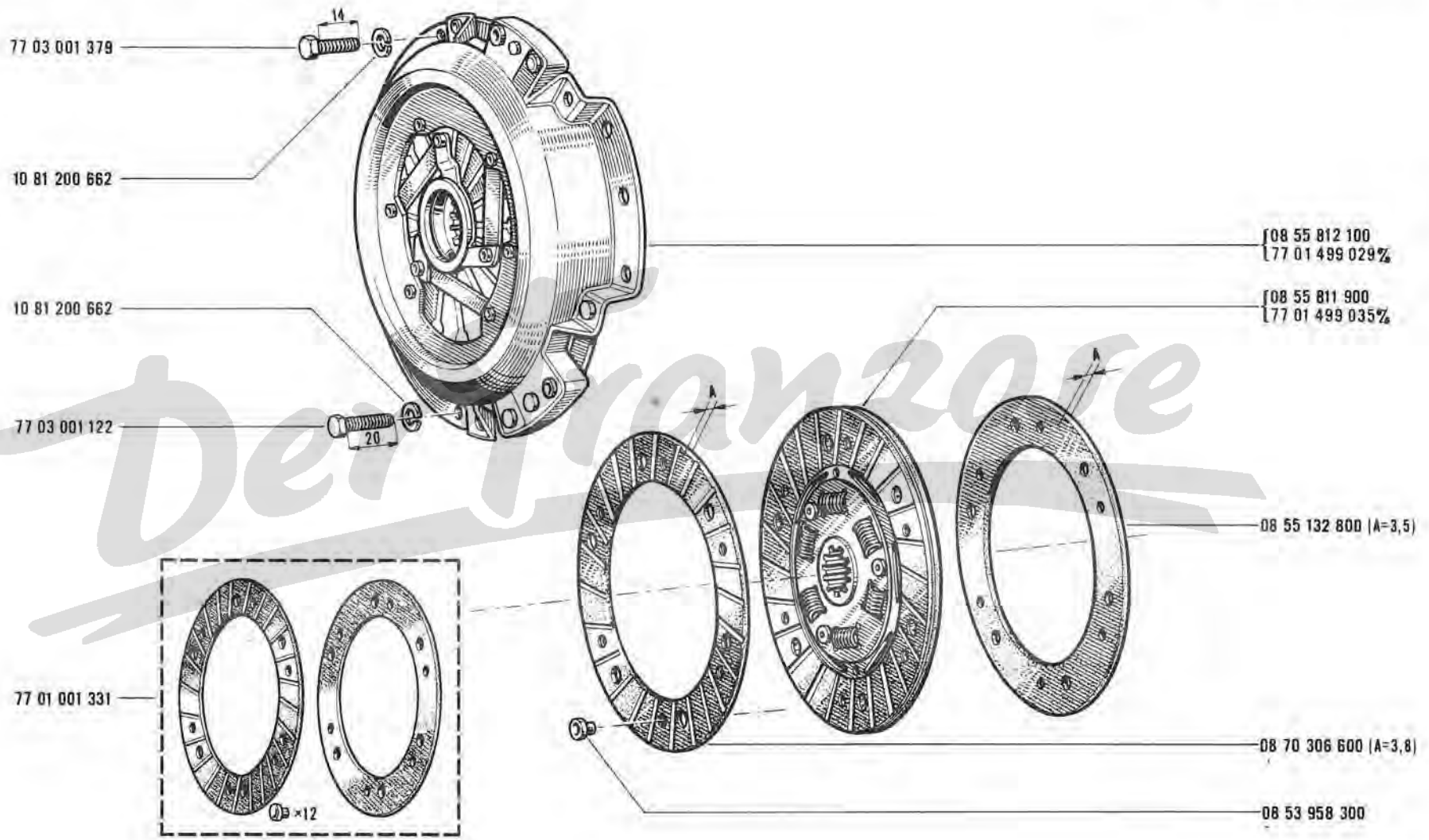

Derivazione

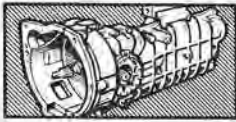

31.01

B P.R. 810

31.01

B P.R. 810

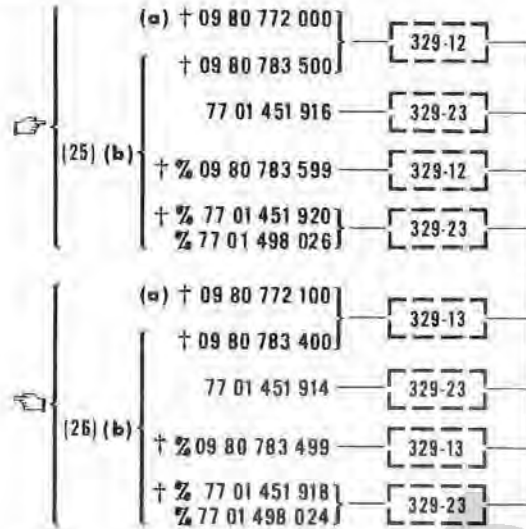
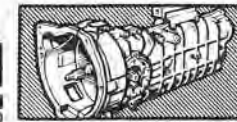

(a) MOT 688-01 n° 1 ⇨ MOT 688-01 n° 79041
 (b) MOT 688-01 n° 79042 ⇨ MOT 688-01 n° . . .

(25) MOT 688-01 n° 1 ⇨ MOT 688-01 n° 79041
 ⇨ 09 96 094 400 -1- NT 431

(26) MOT 688-01 n° 1 ⇨ MOT 688-01 n° 79041
 ⇨ 09 96 094 300 -1- NT 431

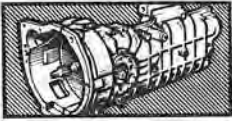

31.10

B P.R.810

31.10

B P.R.810

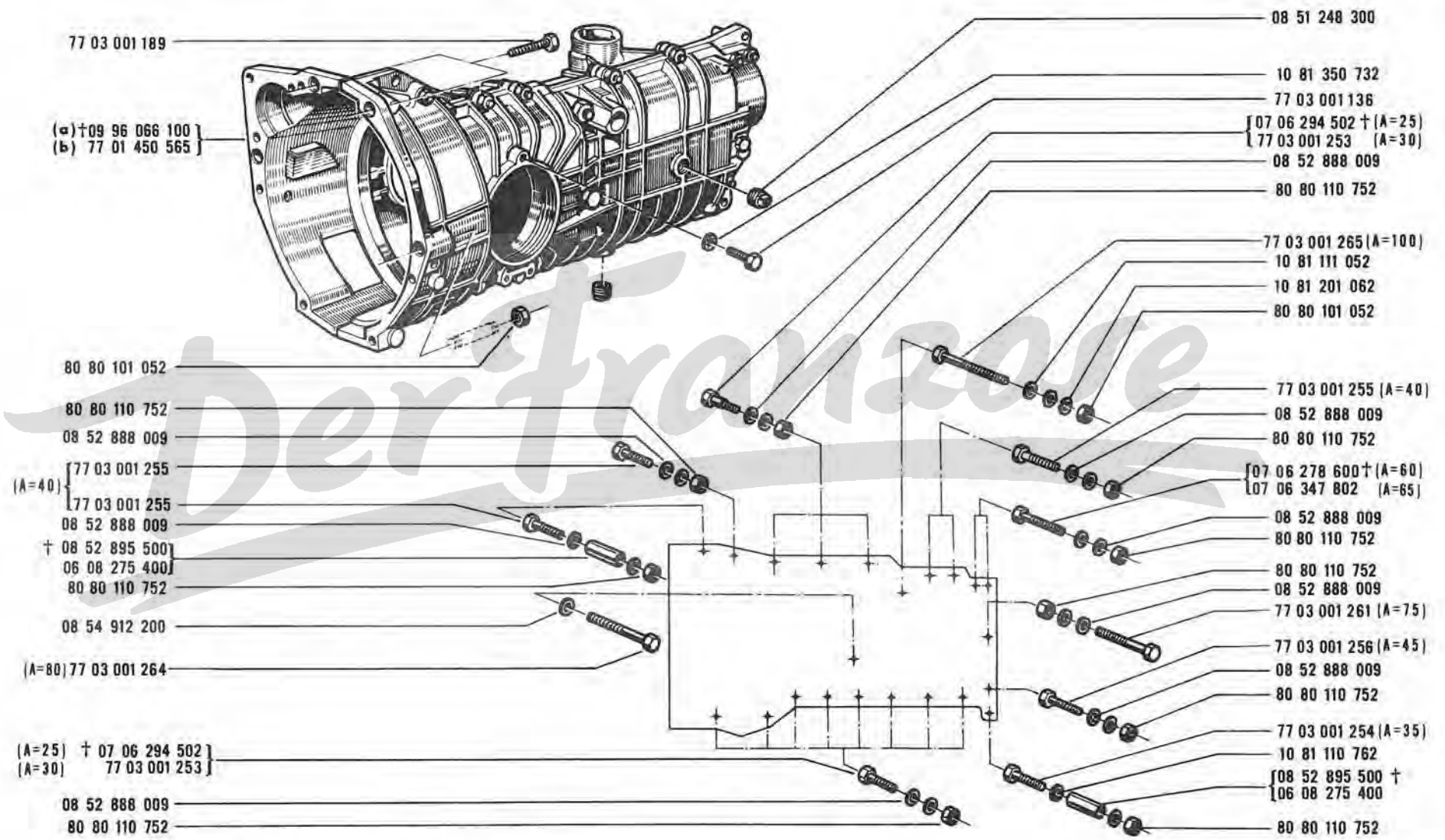
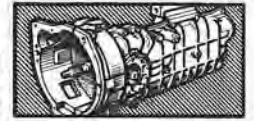

(a)	BP 329-12 n°	1	⇔	BP 329-12 n°	389
	BP 329-13 n°	1	⇔	BP 329-13 n°	74600
	BP 329-12 n°	390	⇔	BP 329-12 n°	...
(b)	BP 329-13 n°	74601	⇔	BP 329-13 n°	...
	BP 329-23				

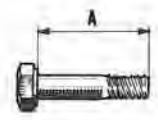

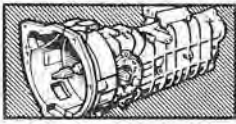

31.13

B P.R.810

31.13

B P.R.810

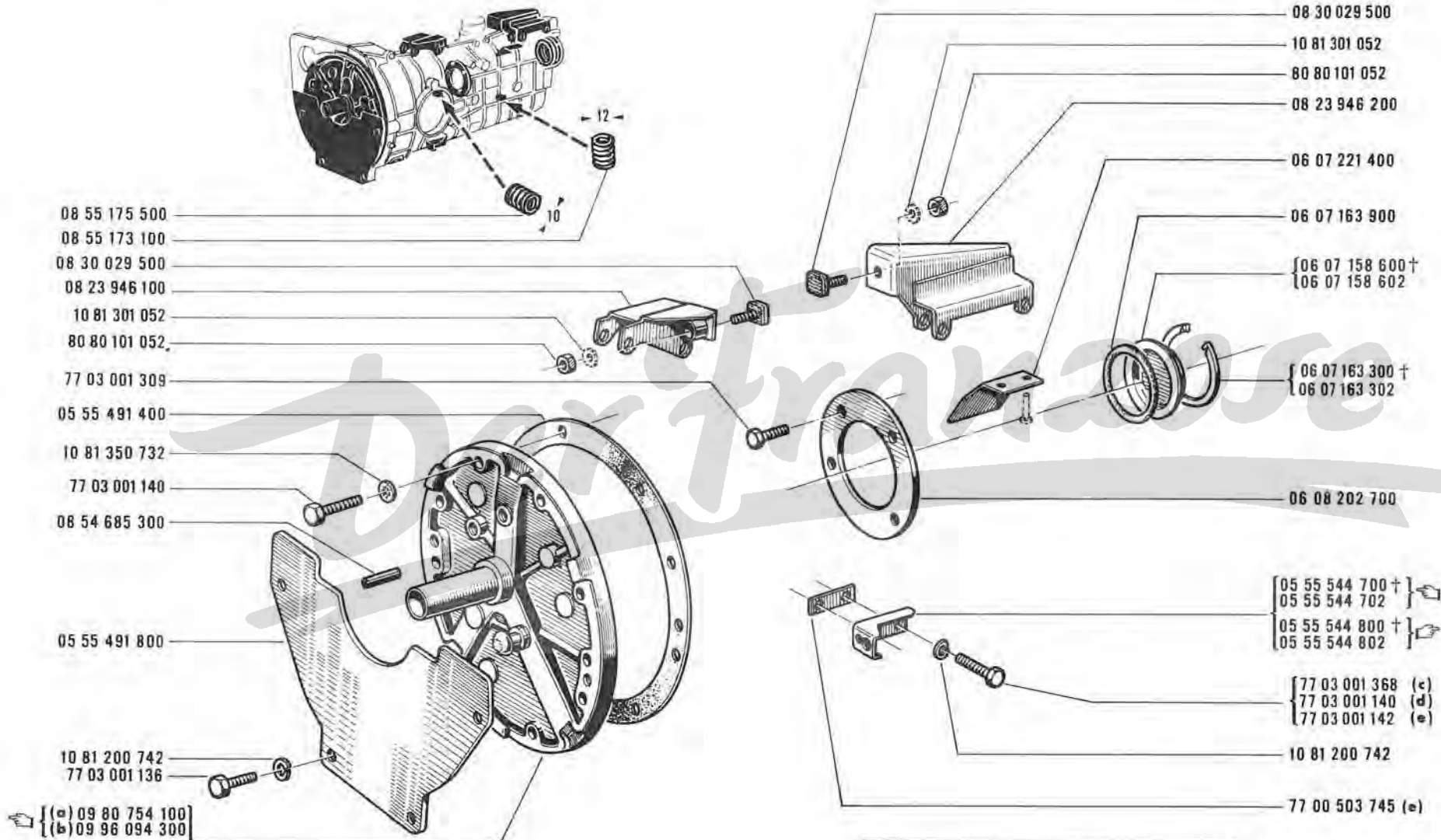
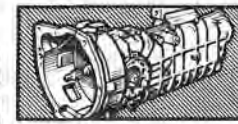

- ☞ {(a) 09 80 754 100
- ☞ {(b) 09 96 094 300
- ☞ {(a) 09 80 754 200
- ☞ {(b) 09 96 094 400

(a) MOT 688-01 n° 1 ⇨ MOT 688-01 n° 79041
 (b) MOT 688-01 n° 79042 ⇨ MOT 688-01 n° ...

(c)	BP 329-12 n°	1 ⇨ BP 329-12 n°	346
	BP 329-13 n°	1 ⇨ BP 329-13 n°	61482
(d)	BP 329-12 n°	347 ⇨ BP 329-12 n°	380
	BP 329-13 n°	61483 ⇨ BP 329-13 n°	...
(e)	BP 329-12 n°	381 ⇨ BP 329-12 n°	...
	BP 329-23		

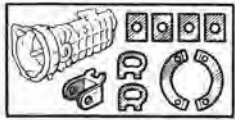

31. 15

B P.R. 810

31. 15

B P.R. 810

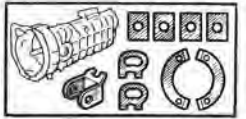

09 96 066 200

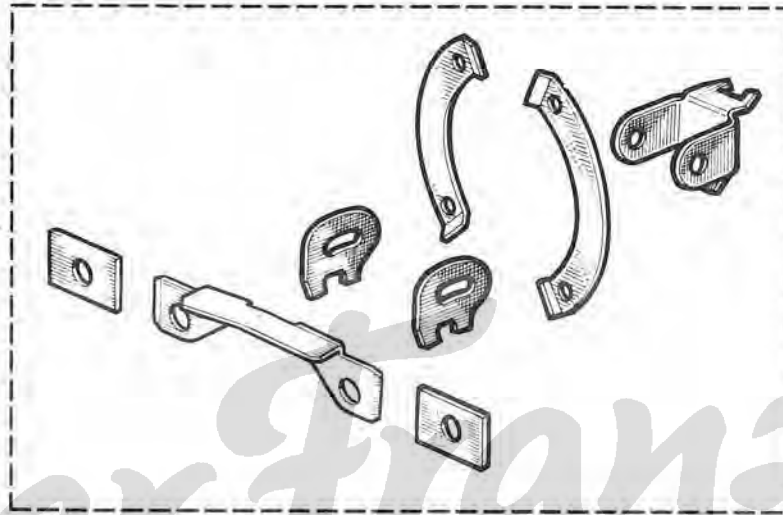

Der Franzose

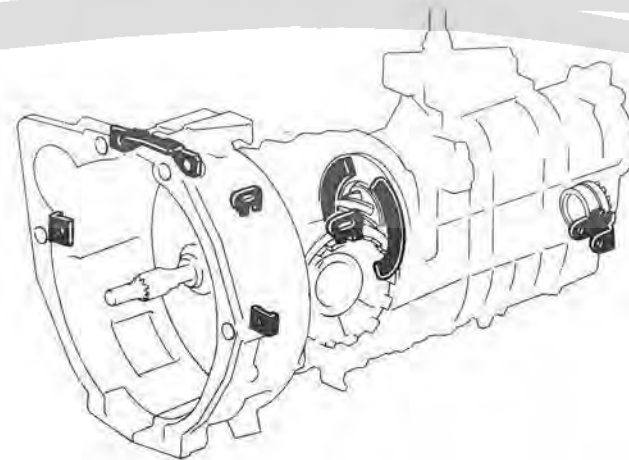

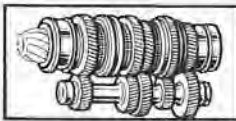

31.20

B P.R. 810

31.20

B P.R. 810

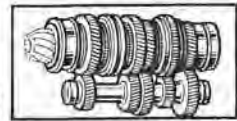

- †05 54 711 700
- 05 56 418 200
- †04 27 522 000
- 04 28 885 200
- ⊙32 04 28 225 800
- †06 07 966 200
- †06 08 515 700
- 77 00 502 279
- †05 55 483 600
- 05 56 255 200
- 06 08 191 000
- 06 07 258 700
- 35×80×43,5 08 52 851 800
- (2)
- ⊙23 04 28 279 000
- 04 27 521 900
- 05 54 617 100
- 06 04 743 100
- 08 24 392 700

- 06 05 785 200
- 08 24 383 600
- 06 05 775 000
- {06 05 774 900 †
- {77 00 502 278
- 04 28 225 700 (⊙=29)
- 07 70 600 800 (40×68×15)
- 06 05 217 900
- 07 70 620 700 (35×72×17)
- 06 06 956 100
- (1)
- 04 28 496 600 (⊙=18)
- 08 54 087 700 (25×31×21,2)
- 06 05 217 800
- 08 33 097 600
- 06 07 977 800
- 08 57 557 000
- 06 07 256 800
- 08 54 912 400
- {07 73 020 300 †
- {08 57 615 300 } (17×40×13,2)
- 04 28 496 400
- 06 07 162 700

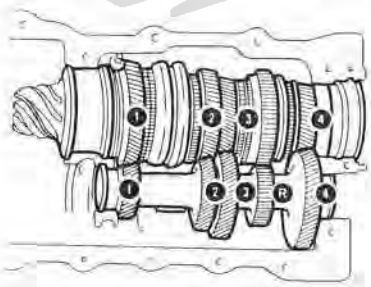
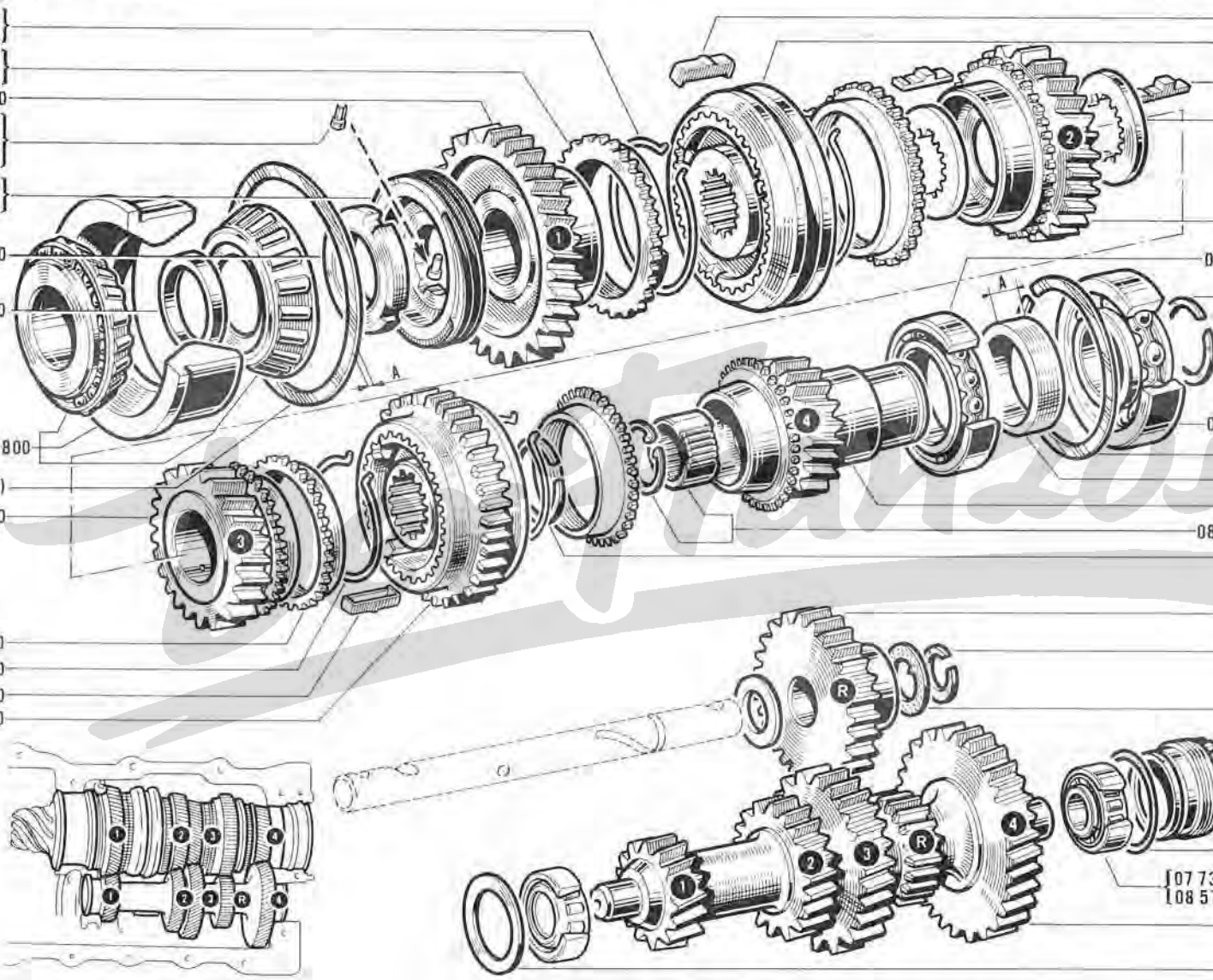

(1)		(2)	
06 05 774 500 A=12	06 07 172 100 A=0,25	06 07 045 500 A=1	
06 05 774 600 A=12,1	06 07 045 200 A=0,7	06 07 045 600 A=1,1	
06 05 774 700 A=12,2	06 07 045 300 A=0,8	06 07 045 700 A=1,2	
06 05 774 800 A=12,3	06 07 045 400 A=0,9	06 07 045 800 A=1,3	

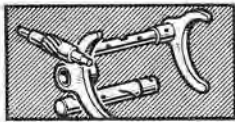

31.30

B P.R. 810

31.30

B P.R. 810

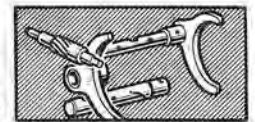

† 06 03 450 100
06 03 450 102

10 81 110 852

05 55 502 400

06 04 319 900

06 05 789 900

07 72 590 900

07 06 291 000

08 53 780 000

† 08 23 915 700

† 04 28 259 300

† 09 80 745 600
77 01 452 166

80 83 100 842

06 08 013 200

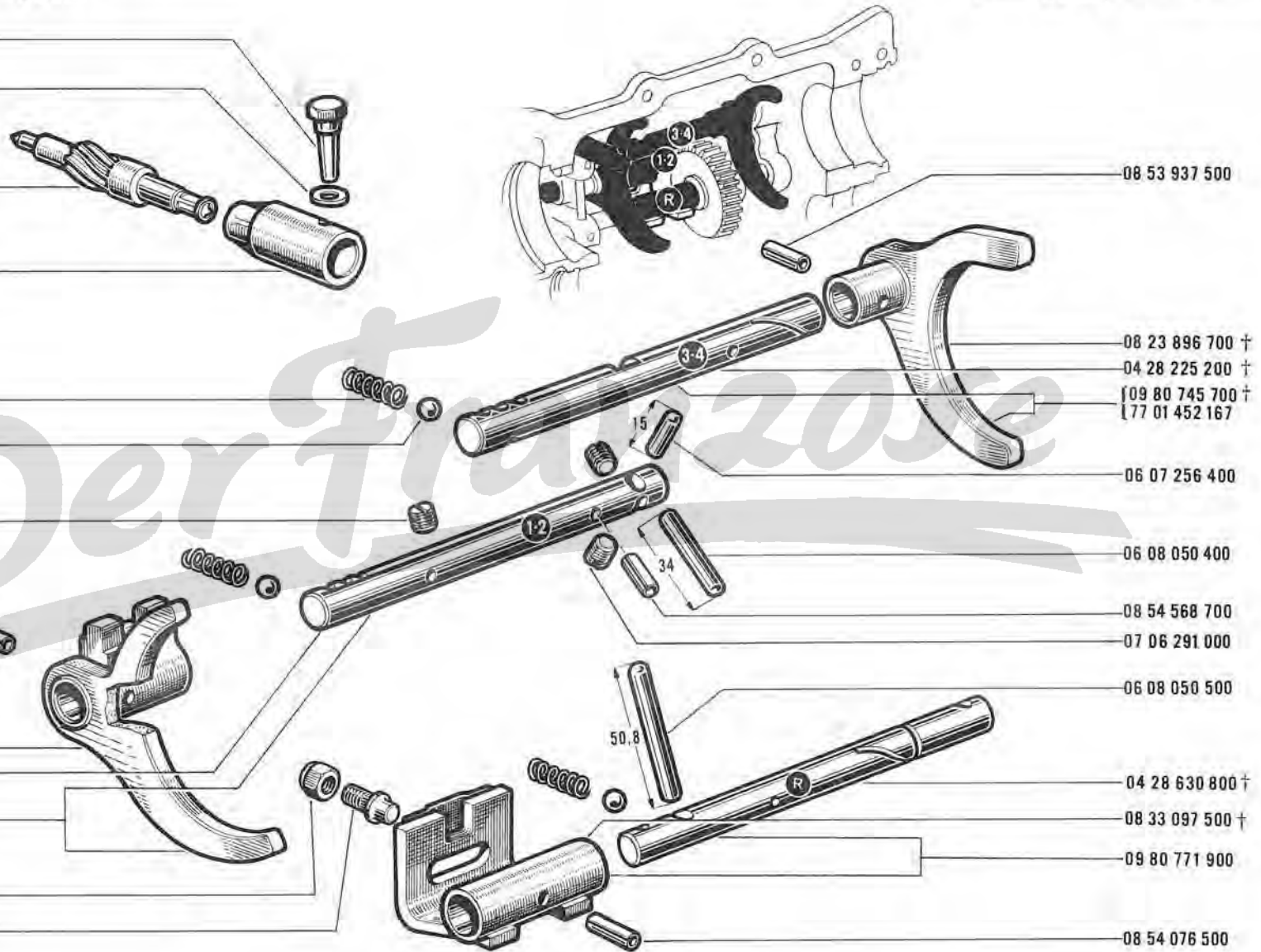

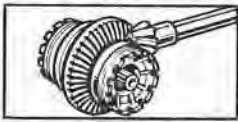

31.40

B P.R. 810

31.40

B P.R. 810

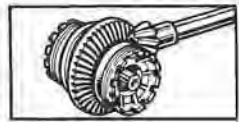

140x90x25.5 | 07 73 130 800

5555426

6059828

4286362

5560496

5560478

8575537

5560495

6080433

4286363

72

102

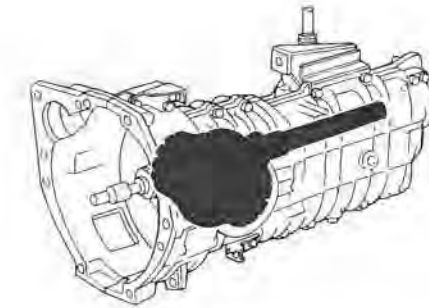

6080447

09 80 777 200 (7x41)

07 73 020 800 (40x80x20)

08 54 912 300

05 55 542 700

08 53 540 700



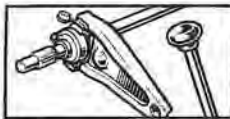

31.50

B P.R. 810

31.50

B P.R. 810

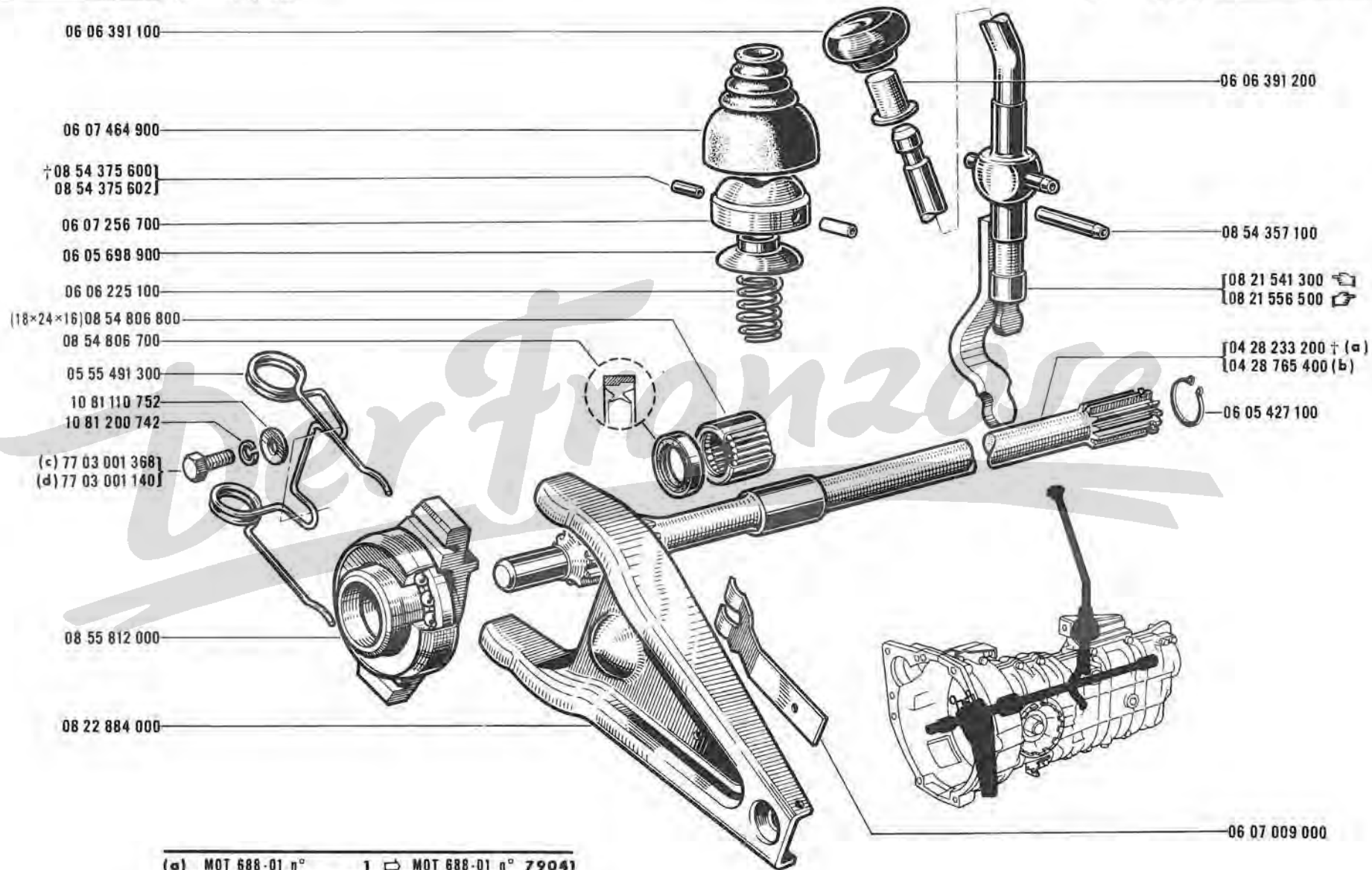
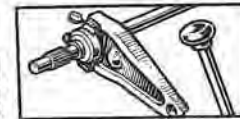

(a)	MOT 688-01 n°	1	⇨	MOT 688-01 n°	79041
(b)	MOT 688-01 n°	79042	⇨	MOT 688-01 n°	...
(c)	BP 329-12 n°	1	⇨	BP 329-12 n°	246
	BP 329-13 n°	1	⇨	BP 329-13 n°	38079
(d)	BP 329-12 n°	247	⇨	BP 329-12 n°	...
	BP 329-13 n°	38080	⇨	BP 329-13 n°	...



40.01

B P.R. 810

40.01

B P.R. 810



- (a) 8519949
- (c) 8519949
- (b) 8700797
- (d) 8700797

8519937

- (a) 8519938
- (c) 8519938
- (b) 8542682
- (d) 8542682

- (a) 8540046
- (c) 8540046

8541573
8519839

- (a) 8556195
- (b) 8700798
- (c) 8556206
- (d) 8700794

8519839
8519840

8538729

- (a) 8537337
- (c) 8537337
- (b) 8540693
- (d) 8540693

- (a) 8555443
- (18) 8557811
- (b) 8555444
- (19) 8557810
- (c) 8555444
- (d) 8557810

08 52 491 600

(a)	VEH n°	1	⇨	VEH n°	4301
(b)	VEH n°	4302	⇨	VEH n°	...
(c)	VEH n°	1	⇨	VEH n°	6118
(d)	VEH n°	6119	⇨	VEH n°	...

- 8556194 (a)
- 8700793 (b)
- 8556205 (c)
- 8700792 (d)

8556204

8519860

8543690

8070 040062

8556202

- 8556196 (a)
- 8700799 (b)

- 8556207 (c)
- 8700795 (d)

8520373

8556197

8556198

- 8556201 (a)
- (c)

- 8556199 (a)
- (c)

- 8700796 (b)
- (d)

8540694

- 1081 110862 (a)
- (c)

- 1081 100854 (b)
- (d)

8556203

(18)	VEH n°	1	⇨	VEH n°	4301
					8331435 -I-
(19)	VEH n°	1	⇨	VEH n°	6118
					8331437 -I-

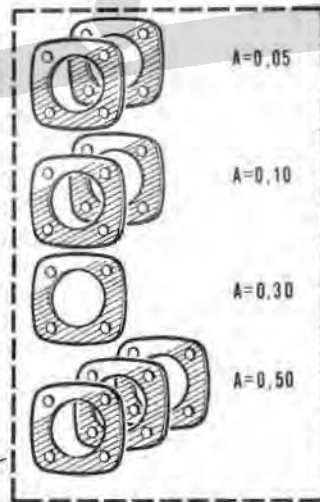



40.10

B P.R. 810

40.10

B P.R. 810



(c) † 08 23 700 500
(d) 09 96 136 900

10 81 200 862

80 80 100 852

77 03 001 049

77 03 001 329

10 81 200 662

05 54 964 000

05 54 957 200

10 81 110 752

10 81 200 762

80 80 100 752

06 07 992 400

77 03 001 127

[A=25] 77 03 001 242

[A=30] 77 03 001 243

10 81 201 062

[A=40] 77 03 001 244

☞ [(a) 08 23 860 000]
☞ [(b) 08 33 143 500]
☞ [(e) 08 23 860 100]
☞ [(f) 08 33 143 700]

77 03 001 185

80 80 101 052

80 83 101 042

☞ 04 27 913 600
☞ 04 28 105 200

† 06 06 015 200

† 06 06 015 202

77 03 001 264

08 54 282 700

77 03 001 158

06 06 097 300 (c)

08 54 868 000 (d)

[07 06 232 700 †
77 00 500 472

[08 22 703 900 †
09 81 959 000 †
77 01 500 004

05 53 637 900

10 89 020 200

80 80 170 852

07 06 274 700

08 54 340 400

06 06 273 800

05 53 430 500

80 80 100 652

10 81 200 662

07 06 251 600

06 04 689 100

(a) VEH n° 1 ⇨ VEH n° 4301

(b) VEH n° 4302 ⇨ VEH n° ...

(c) VEH n° 1 ⇨ VEH n° 9971

(d) VEH n° 9972 ⇨ VEH n° ...

(e) VEH n° 1 ⇨ VEH n° 6118

(f) VEH n° 6119 ⇨ VEH n° ...

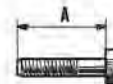



40.15

A P.R.810

40.15

A P.R.810



08 53 509 100

08 53 509 200

08 54 638 400

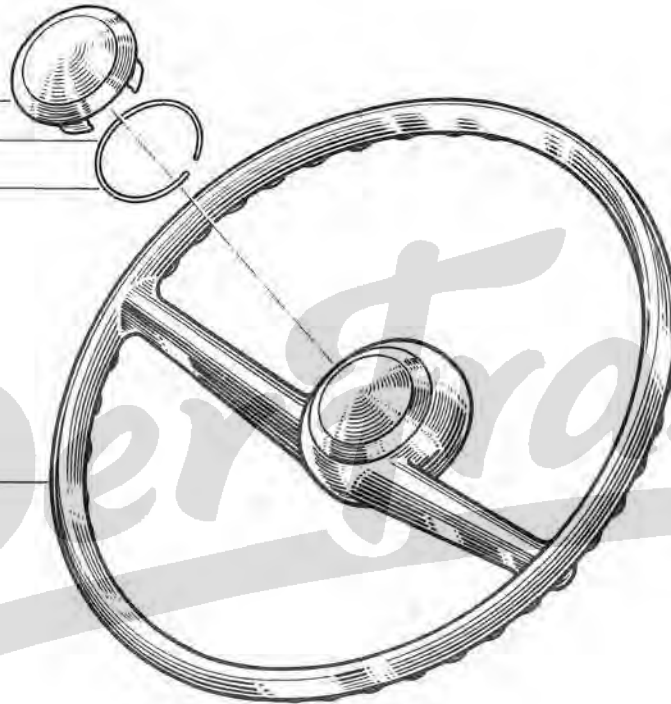

Der Franzose

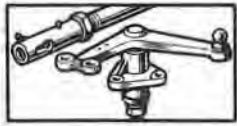

40.20
B P.R. 810



40.20
B P.R. 810

[9819508]
[9819522]

[9819488]
[9819489]

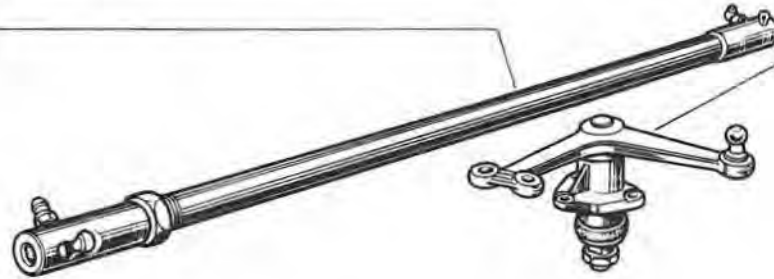

† 06 07 079 800]
06 07 079 802]

6070797

6069644

6069686

6070801

1089 040450

[8238800]

[8331010]

† 08 51 126 900]
77 01 000 755]

6069687

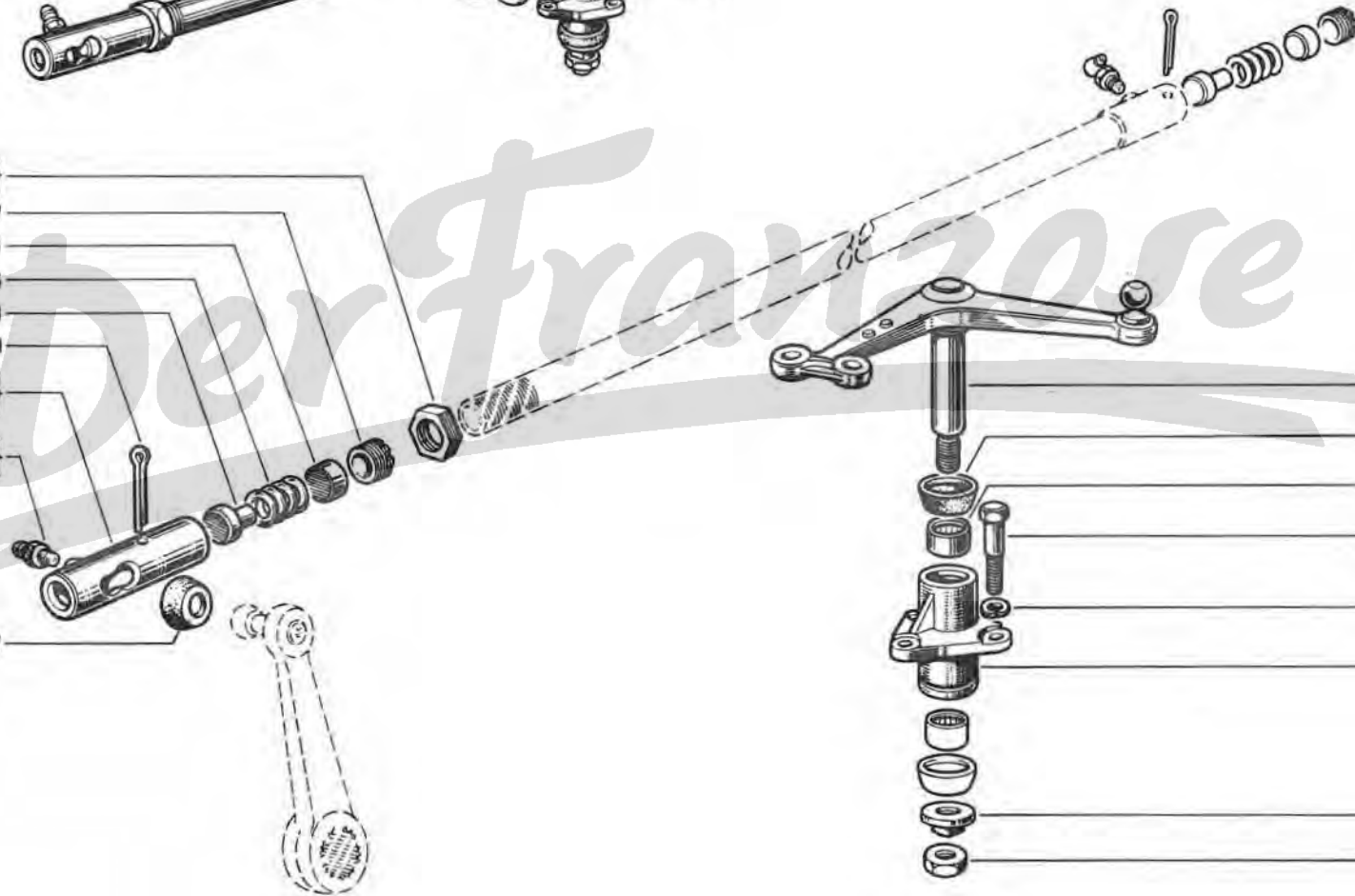

[8214737]
[8214738]

6060071

8539715

77 03 001 243

10 81 201 062

4283808

06 06 007 302

7062857

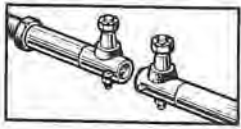

40.30

B P.R. 810

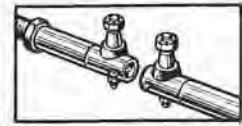

40.30

B P.R. 810

9819495

5554350

9819494

6069835

8545969

{ 06 07 079 800 †
06 07 079 802

8545969

9819492

6069689

6072590

6069644

6069840

6069835

1089 020250

07 06 315 906

1089 040450

6070797

6069840

6069644

6069686

9819493

† 06 07 079 900]

06 07 079 902]

5554349

1089 040450

6070797

1089 020250

07 06 315 906

Daifranzose

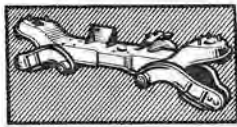

42.01

B P.R. 810

42.01

B P.R. 810

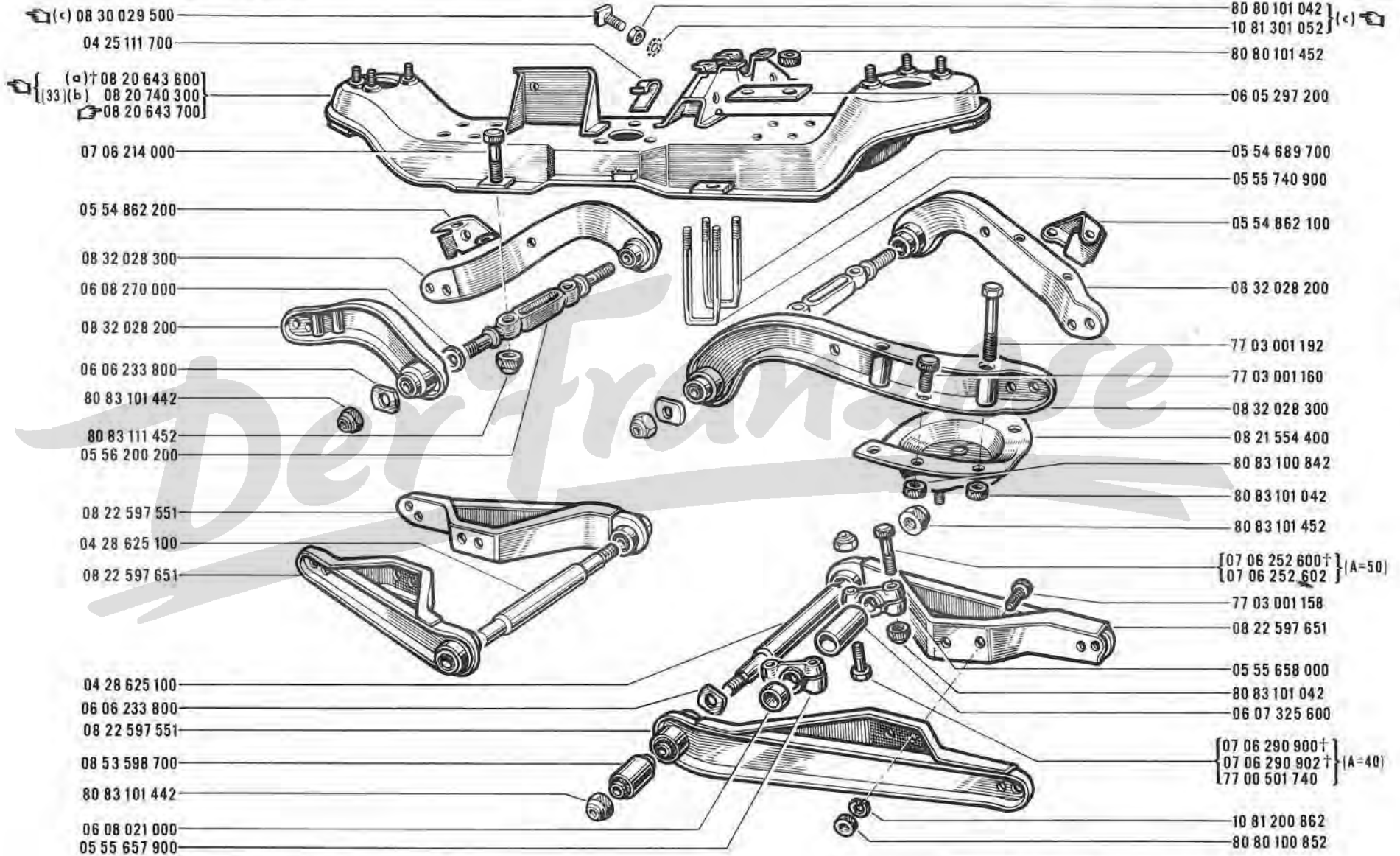
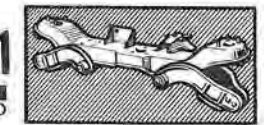

(a) VEH n° 1 ⇨ VEH n° 9736

(b) VEH n° 9737 ⇨ VEH n° ...

(c) VEH n° 4341 ⇨ VEH n° ...

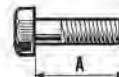

(33) VEH n° 1 ⇨ VEH n° 9736



07 06 303 200 -1-

08 55 932 000 -1-

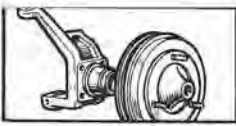

42.10

B P.R. 810

42.10

B P.R. 810

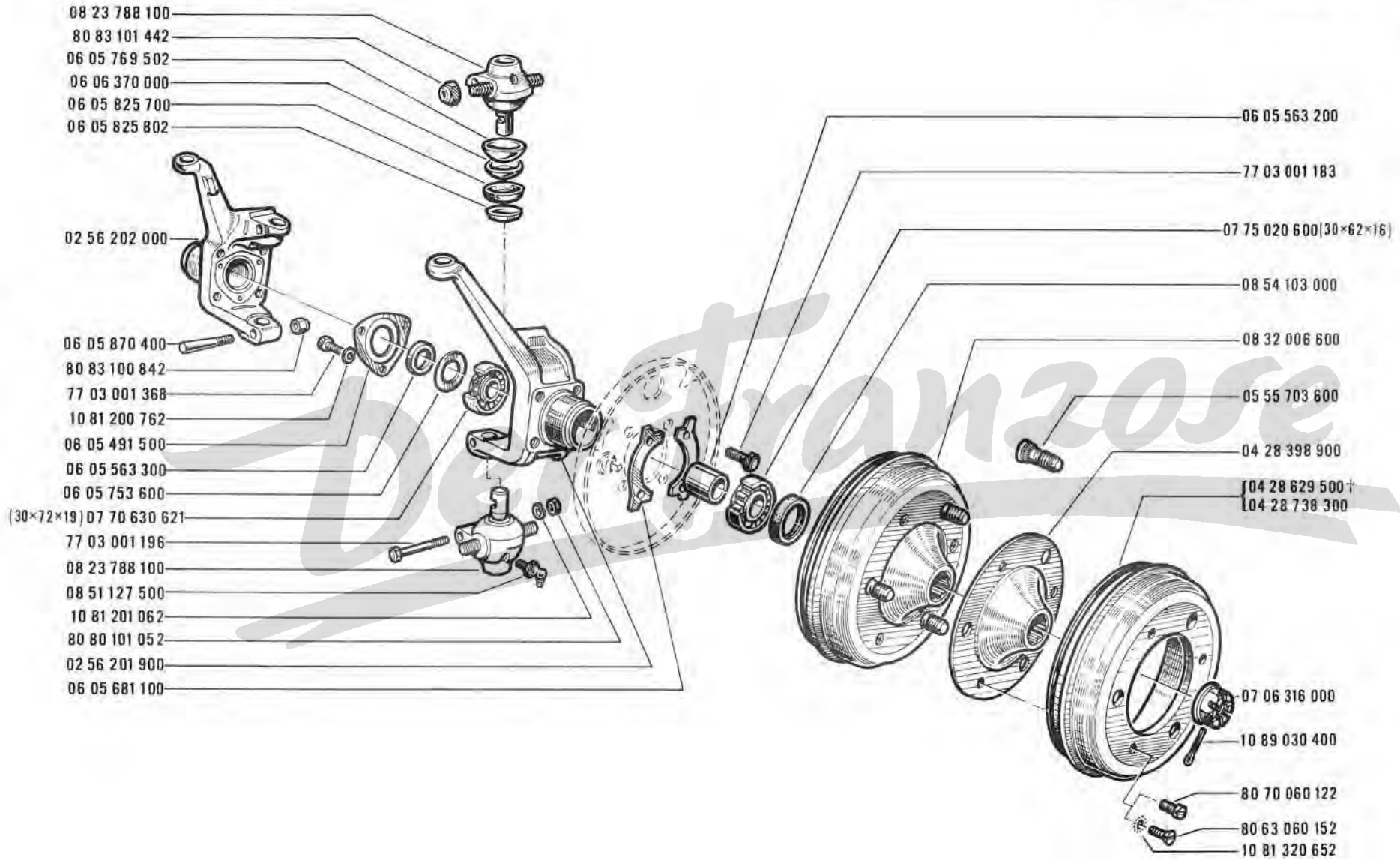
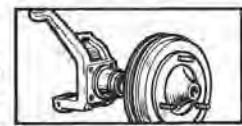

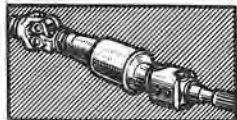

42.20

B P.R. 810

VEH n°

1 ⇨ VEH n° 16401 ☒ (2)

42.20

B P.R. 810

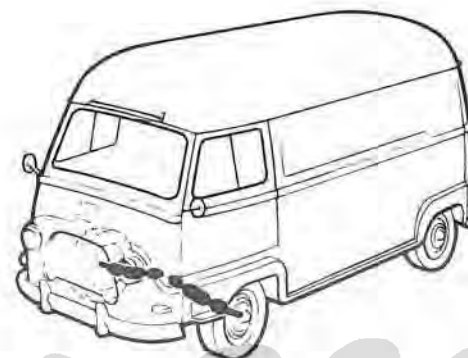
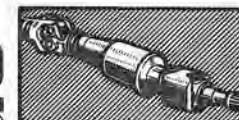

77 03 001 182

1081 311052

06 06 293 300

- (a) { $\frac{1}{4}$ † 08 21 662 500
 † 08 21 662 599
 † 08 21 746 800
 † 08 21 746 899
- (b) { (42) † 09 96 112 800
 $\frac{1}{4}$ 09 96 112 899

(a) VEH n° 1 ⇨ VEH n° 5329
 (b) VEH n° 5330 ⇨ VEH n° 16401 ☒ (2)

(2) VEH n° 16389,16396

(42) ☒ 77 01 450 529 -1-

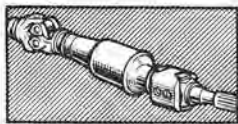

42.25

A P.R.810

VEH n° 16402 ⇨ VEH n°... ↗(2)

42.25

A P.R.810

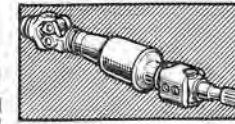

77 01 002 536

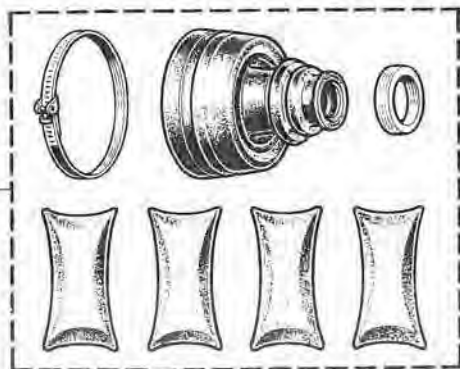

06 06 293 300

77 03 001 185

77 00 503 646



77 01 450 529	†	} (43)
77 01 453 033	†	
77 01 450 530	†	} 2/4
77 01 498 013	†	

(47) 77 01 002 538

77 01 002 537



77 01 002 539

(2) VEH n° 16389 ,16396

(43) 06.01 ...

(47) 77 01 002 536 -1-

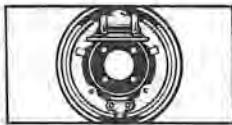

42.30

B P.R. 810

42.30

B P.R. 810



08 55 617 800

0851 880 200

0855 643 600

08 51 250 200

08 51 250 100

0852 449 800

† 08 54 956 800

08 70 046 800

08 55 617 900

77 01 499 045

08 51 355 800

0855 643 400

0851 880 400

0981 735 100 (a)

0981 753 900 (b)

0981 735 000 (a)

0981 753 800 (b)

0855 617 700

0851 880 300

08 55 643 500

08 55 618 000

77 01 499 053 1/2

77 01 002 398

08 51 797 000

08 51 880 500

(a) VEH n° 1 ⇨ VEH n° 11966 (1)

VEH n° 1 ⇨ VEH n° 18522

(b) VEH n° 11967 ⇨ VEH n° ... (1)

VEH n° 18523 ⇨ VEH n° ...

(1) VEH n° 11915, 11921, 11934, 11948, 11949, 11952 ⇨ 11964

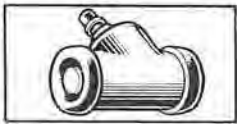

42.35

B P.R. 810

42.35

B P.R. 810

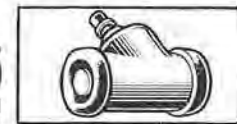

(a) 0854 956 700
(b) 0854 149 500

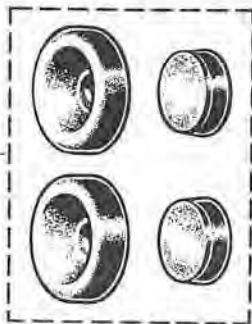

{ 0854 954 800 (a)
0870 596 200 (b)

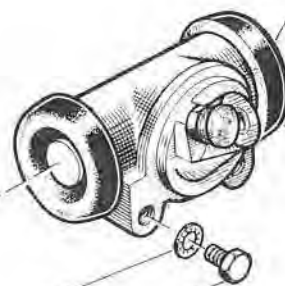

08 52 289 700

77 03 001 116

06 03 936 600

+ 08 54 176 900
08 54 286 800

(a) 05 52 659 000
(b) 02 54 608 400

(a) 06 04 194 800
(b) 08 52 287 700

06 05 991 400

(a) 06 05 850 300
(b) 08 51 974 700

08 53 872 600

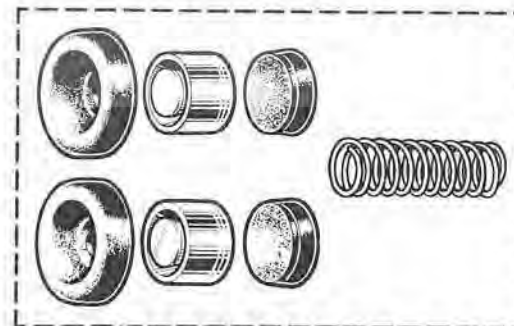
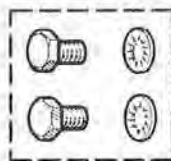
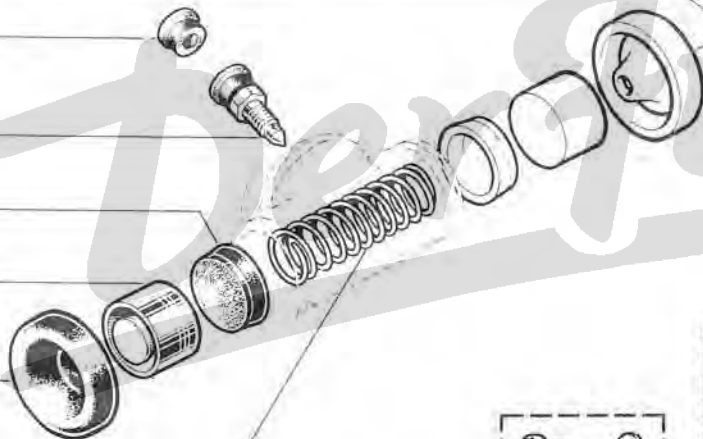

{ 0854 954 700 (a)
0870 596 100 (b)

{ 08 54 956 600 (a)
08 54 164 400 (b)

(a)		VEH n°	1	⇨	VEH n° 11966	☒ (1)
		VEH n°	1	⇨	VEH n° 18522	
(b)		VEH n°	11967	⇨	VEH n°...	☒ (1)
		VEH n°	18523	⇨	VEH n°...	

(1) VEH n° 11915, 11921, 11934, 11948, 11949, 11952 ⇨ 11964



43.01

B P.R. 810

43.01

B P.R. 810



[A=50] { + 07 06 252 600 }
 { 07 06 252 602 }

[A=40] { + 07 06 290 900 }
 { + 07 06 290 902 }

[A=38] 77 00 501 740

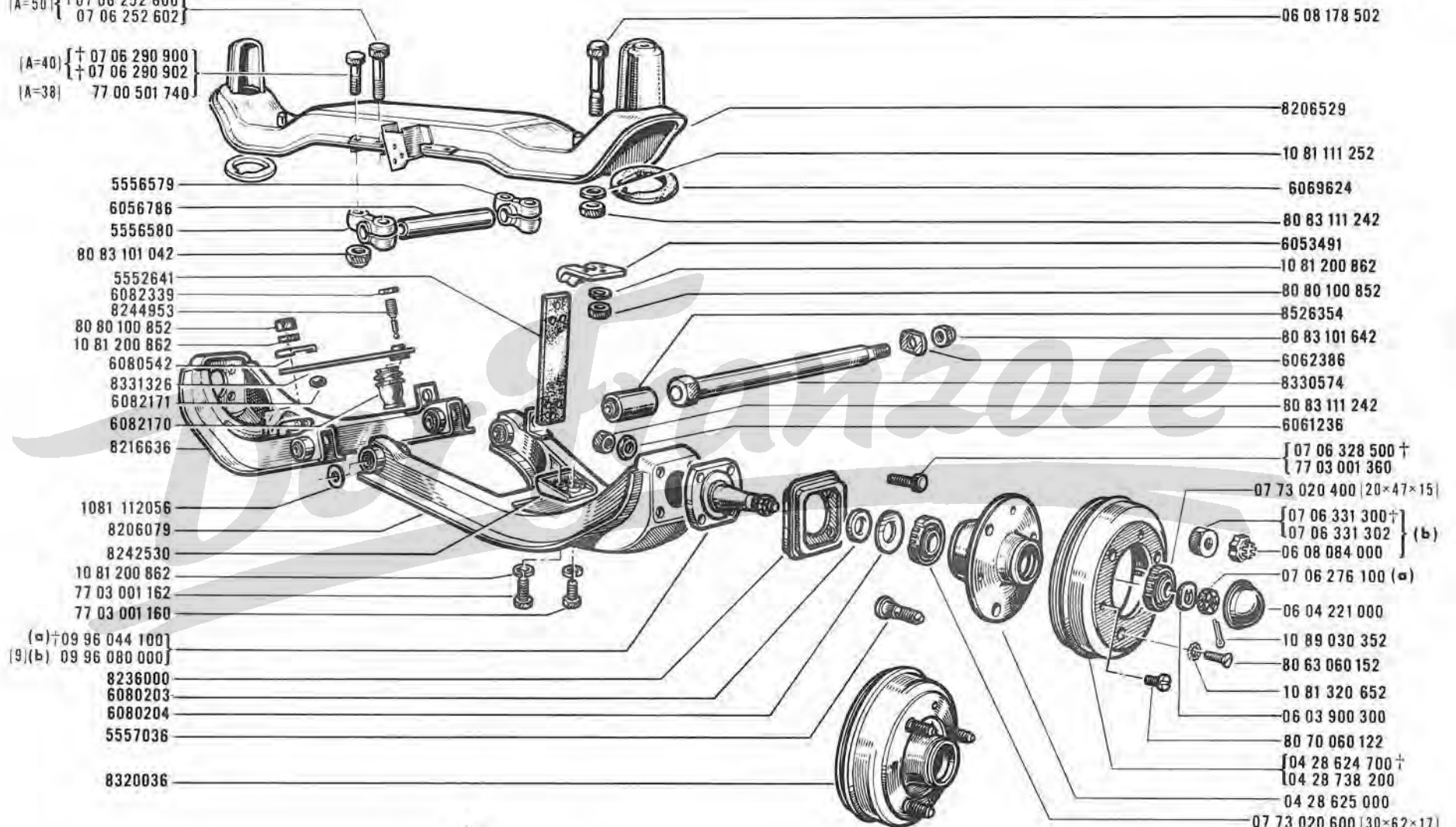

5556579

6056786

5556580

80 83 101 042

5552641

6082339

8244953

80 80 100 852

10 81 200 862

6080542

8331326

6082171

6082170

8216636

1081 112056

8206079

8242530

10 81 200 862

77 03 001 162

77 03 001 160

(a) + 09 96 044 1001

(9)(b) 09 96 080 000

8236000

6080203

6080204

5557036

8320036

06 08 178 502

8206529

10 81 111 252

6069624

80 83 111 242

6053491

10 81 200 862

80 80 100 852

8526354

80 83 101 642

6062386

8330574

80 83 111 242

6061238

{ 07 06 328 500 +

{ 77 03 001 360

07 73 020 400 | 20x47x15 |

{ 07 06 331 300 +

{ 07 06 331 302 } (b)

06 08 084 000

07 06 276 100 (a)

06 04 221 000

10 89 030 352

80 63 060 152

10 81 320 652

06 03 900 300

80 70 060 122

{ 04 28 624 700 +

{ 04 28 738 200

04 28 625 000

07 73 020 600 | 30x62x17 |



(a) TAR 352-20 n° 1 ⇨ TAR 352-20 n° 7382
(b) TAR 352-20 n° 7383 ⇨ TAR 352-20 n°

(9) TAR 352-20 n° 1 ⇨ TAR 352-20 n° 7382
06 08 084 000 -1-

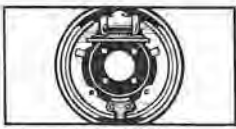

43.10

B P.R. 810

43.10

B P.R. 810

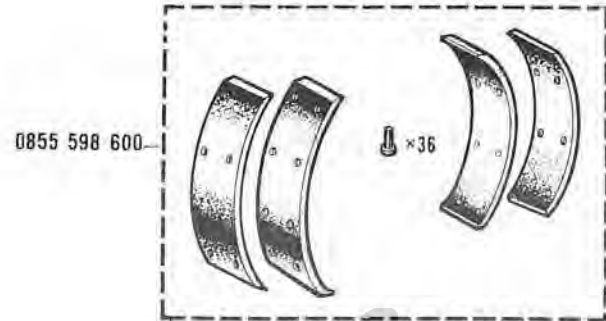
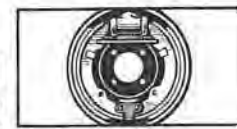

09 81 668 400
77 01 499 061

0852 290 400

0854 958 100

09 81 668 300
77 01 499 057

0851 367 200

0852 913 300

0852 290 300

0981 682 100 (a)
0981 695 900 (b)

0981 682 000 (a)
0981 695 800 (b)

0855 618 100

0852 913 400

(a)	VEH n°	1	⇨	VEH n° 11966	☒ (1)
	VEH n°	1	⇨	VEH n° 18522	
(b)	VEH n° 11967	⇨	VEH n°...	☒ (1)	
	VEH n° 18523	⇨	VEH n°...		

(1) VEH n° 11915, 11921, 11934, 11948, 11949, 11952 ⇨ 11964

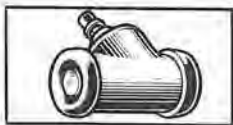

43.15

B P.R. 810

43.15

B P.R. 810

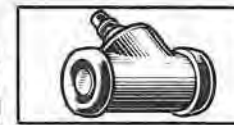

(a) 0854 176 700
(b) 0854 956 700

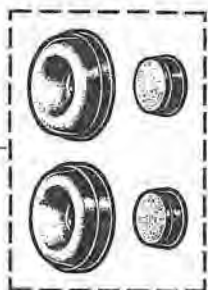

77 03 001 116
08 52 289 700
(a) 08 54 341 100
(b) 77 01 000 525

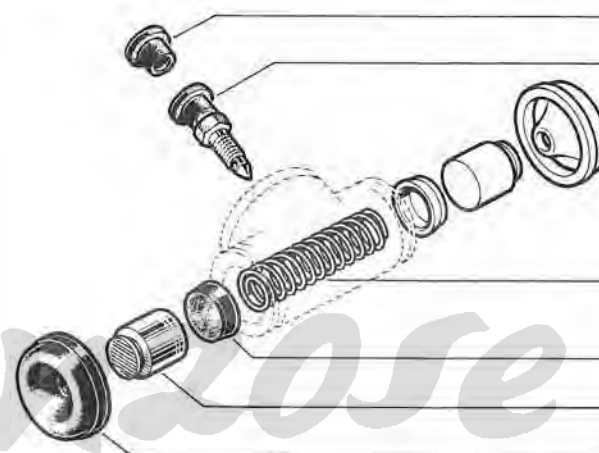
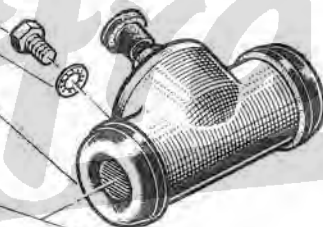

0603 936 600
{0854 176 900+
{0854 286 800

{0605 915 600 (a)
{0605 850 300 (b)

{0552 658 900 (a)
{0552 659 000 (b)
{0604 446 400 (a)
{0604 194 800 (b)
{0605 821 700 (a)
{0605 991 400 (b)

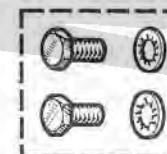

0853 872 600

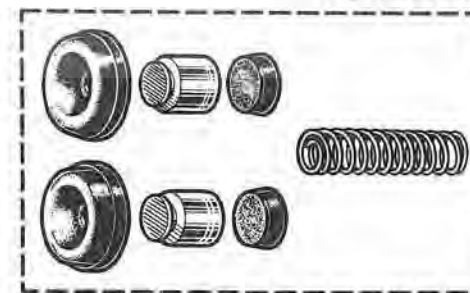

{0854 176 500 (a)
{0854 956 600 (b)

(a)	VEH n°	1	⇨	VEH n° 11966	☒ [1]
	VEH n°	1	⇨	VEH n° 18522	
(b)	VEH n°	11967	⇨	VEH n°...	☒ [1]
	VEH n°	18523	⇨	VEH n°...	

[1] VEH n° 11915, 11921, 11934, 11948, 11949, 11952 ⇨ 11964



44.01

B P.R. 810

44.01

B P.R. 810

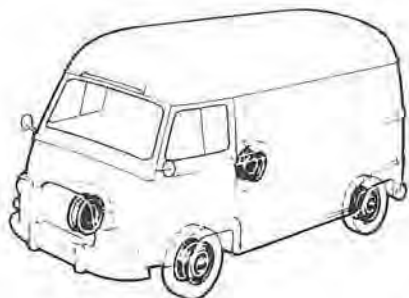

(R 2135) 08 55 057 700
(R 2134) 08 55 568 000

05 55 429 900

08 55 541 900

04 27 686 300 (R 2135) (2)

05 54 741 500†
05 54 741 502

(1) DUNLOP

(2) MICHELIN



44.10
B P.R. 810

44.10
B P.R. 810

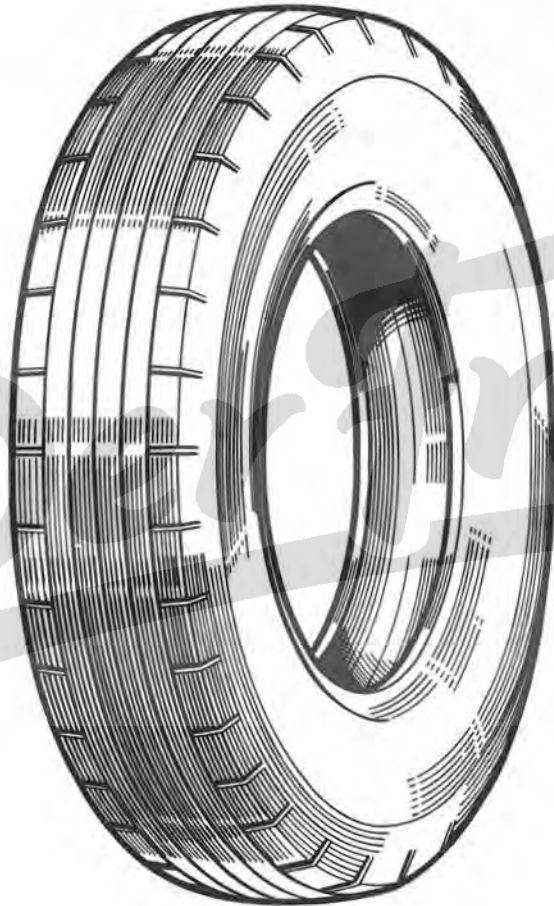

MICHELIN	175×380 X (R.2134)
	165×380 C Pilote } (R.2135)
	165×380 Pilote X }
	6.40-15 Superconfort }
ENGLEBERT	165×380 MAX-M+S+E. (R.2134)
	165×380 Transport } (R.2135)
	165×380 MAX }
	6.40-15 33 }
	175×380 MAX RALLYE (R.2134)
DUNLOP	175×380 SP. (R.2134)
	165×380/ 6.5-15TT } (R.2135)
	165×380/ 165-15 SP }
	6.40-15 D5 }
KLEBER-COLOMBES	175×380 V10 (R.2134)
	165×380 V10 } (R.2135)
	6.40-15 S75 }
	165×380 RS75 }
GOOD-YEAR	175×380 6800 (R.2134)

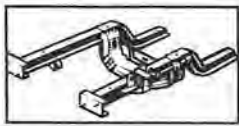

50.10

B P.R. 810



50.10

B P.R. 810

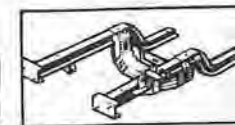

(c) †08 32 008 700
(48) (d) 77 00 504 858

77 03 001 122

10 81110 652

10 81 200 662

8320016

77 03 001 189

80 83 101 042

8214996 (a)

8217858 (b)

04 28 343 700

08 21 642 600

08 53 831 000

8215411

77 03 001 196

77 03 001 194

8236584

8215409

8239539

8236583

10 81 201 062

80 80 101 052

8239540

3537478

8237979

04 28 343 800

(a)	VEH n°	1	⇨	VEH n°	9736
(b)	VEH n°	9737	⇨	VEH n°	...
(c)	VEH n°	1	⇨	VEH n°	17428
(d)	VEH n°	17429	⇨	VEH n°	...

(48) VEH n° 1 ⇨ VEH n° 17428

77 00 504 352 -J-

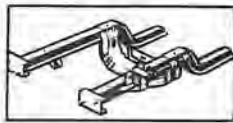

50.20
B P.R. 810



50.20
B P.R. 810

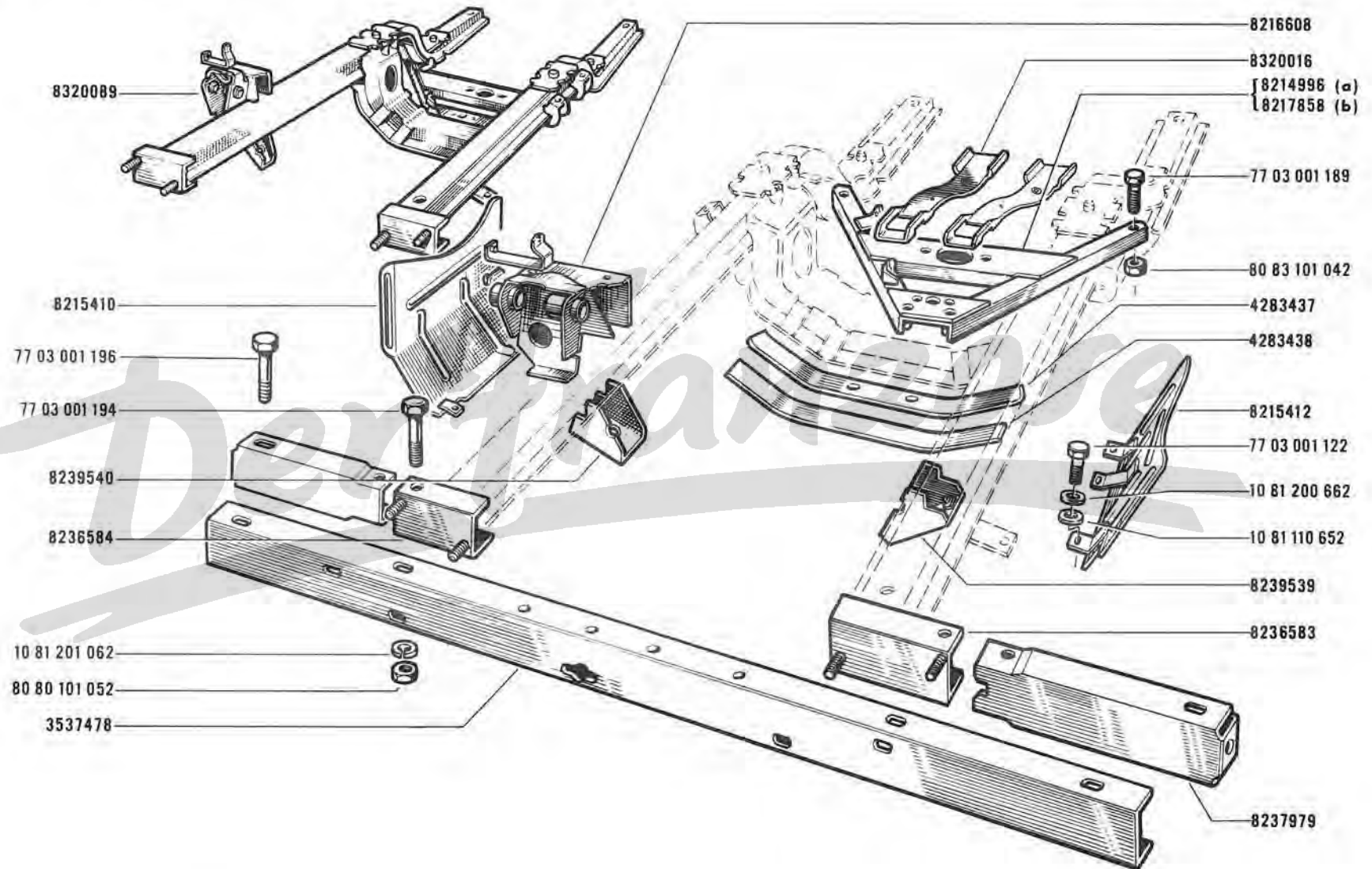
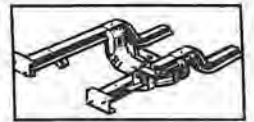

(a) VEH n° 1 ⇨ VEH n° 9736
(b) VEH n° 9737 ⇨ VEH n°

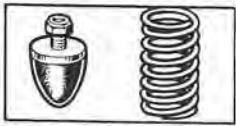

51. 01

B P.R. 810

51. 01

B P.R. 810

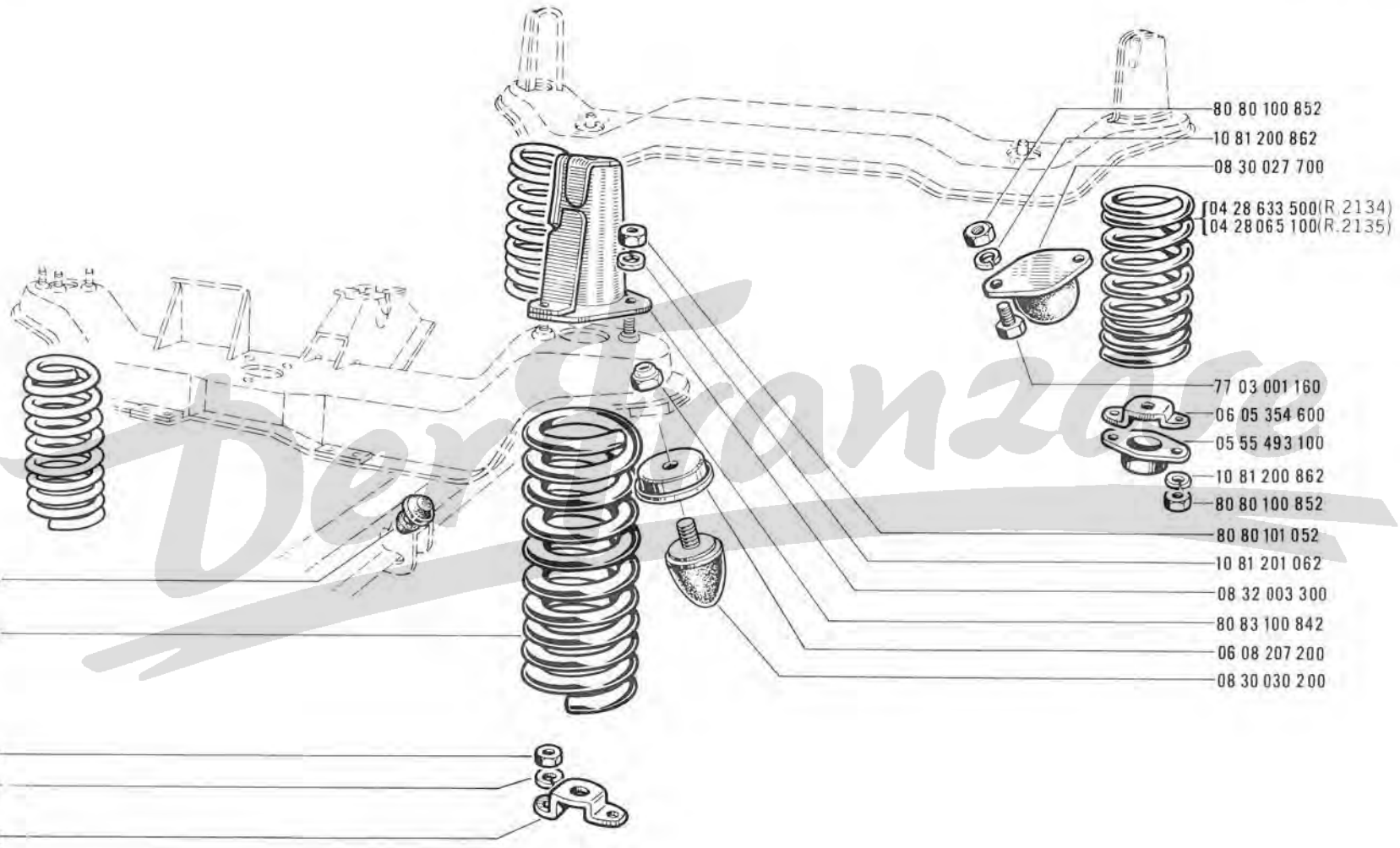
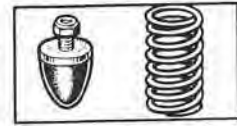

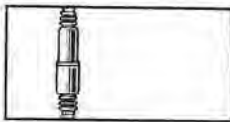

51. 10

B P.R. 810

51. 10

B P.R. 810

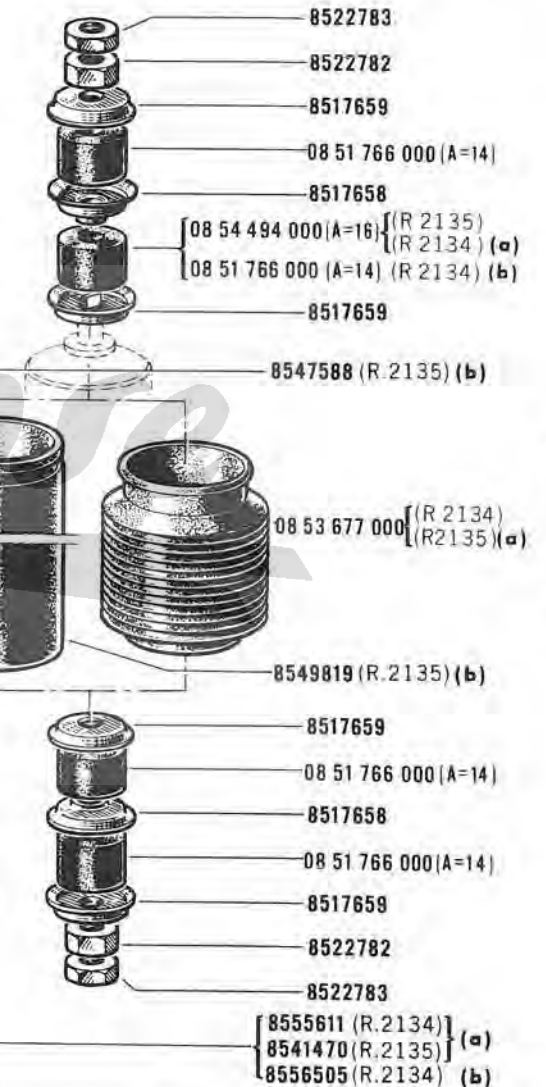
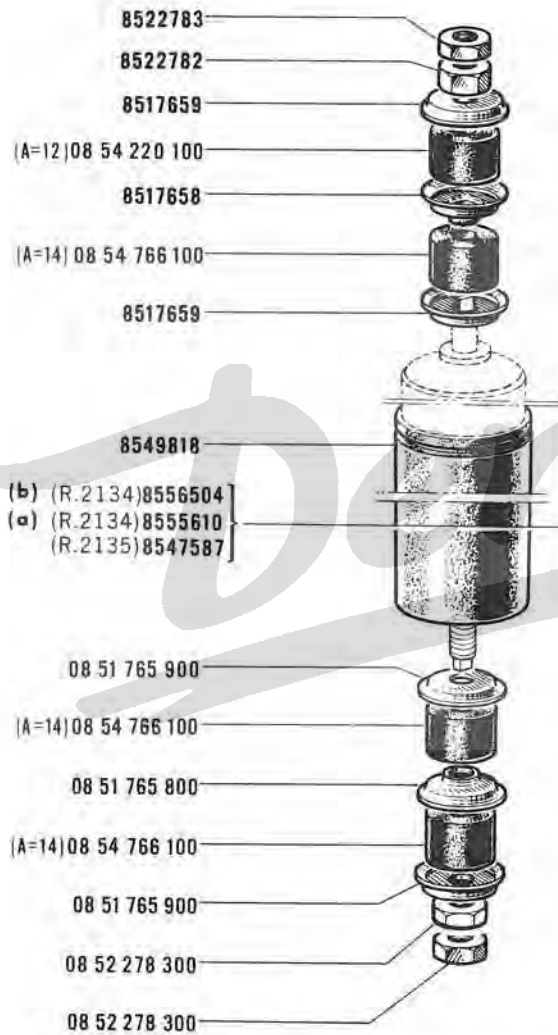
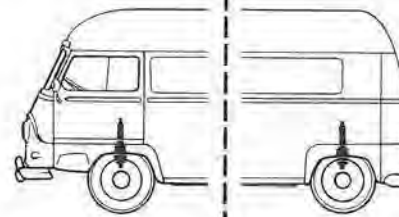

(a)	/10/11/12/13/14/15/18/70/100/101/102/103/120/121/122/130/700
(b)	/20/21/22/24/26/27/28/29/30/40/41/42/80/81/84/86/88/89/140/200/201
	202/203/204/207/211/220/230/231/240/241/242/800/801/803/807/810/811



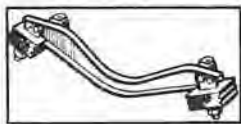

52.01

B P.R.810

52.01

B P.R.810

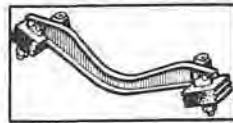

(e) 06 07 625 900
(f) 77 00 508 387

77 03 001 183

08 54 130 500

(c) 08 22 799 000
(d) 08 32 083 000

(b) 07 06 331 702

77 03 001 160

08 30 027 100

10 81 200 862

80 80 100 852

(a) 10 81 200 862
07 06 329 302

(b) 06 08 237 902
80 83 120 852

(d) 06 08 349 302
10 81 301 082
06 08 331 902

77 03 001 374

10 81 111 652

80 80 101 652

06 06 698 400

06 05 296 600

{ 06 05 530 123+
06 05 530 102

80 80 101 652

05 54 720 900

06 07 396 400

{ 06 07 396 500+
06 07 396 502

{ 06 06 326 700+
06 06 326 702

10 81 111 052

80 83 101 052

08 30 027 100

10 81 111 072

80 83 101 042

[2] VEH n° 16389,16396

(a) VEH n° 1 ⇨ VEH n° 3429

(b) VEH n° 3430 ⇨ MOT 688-01 n° 83762

(c) MOT 688-01 n° 1 ⇨ MOT 688-01 n° 83762

(d) MOT 688-01 n° 83763 ⇨ MOT 688-01 n° ...

(e) R2134,R2135 / 10/11/12/13/14/15/18/20/21/22/24/26/27/28/29/30/40/41/42/70/80/81/84/86/88/89

/ 100/101/103/122/130/200/201/202/203/204/207/211/220/230/231/240

102/120/121/140/241/242/700/800/801/803/807/810/811 : VEH n° 1 ⇨ VEH n° 16401 [2]

(f) R2134,R2135 / 102/120/121/140/241/242/700/800/801/803/807/810/811 : VEH n° 16402 ⇨ VEH n° ... [2]



58.01

B P.R. 810



58.01

B P.R. 810

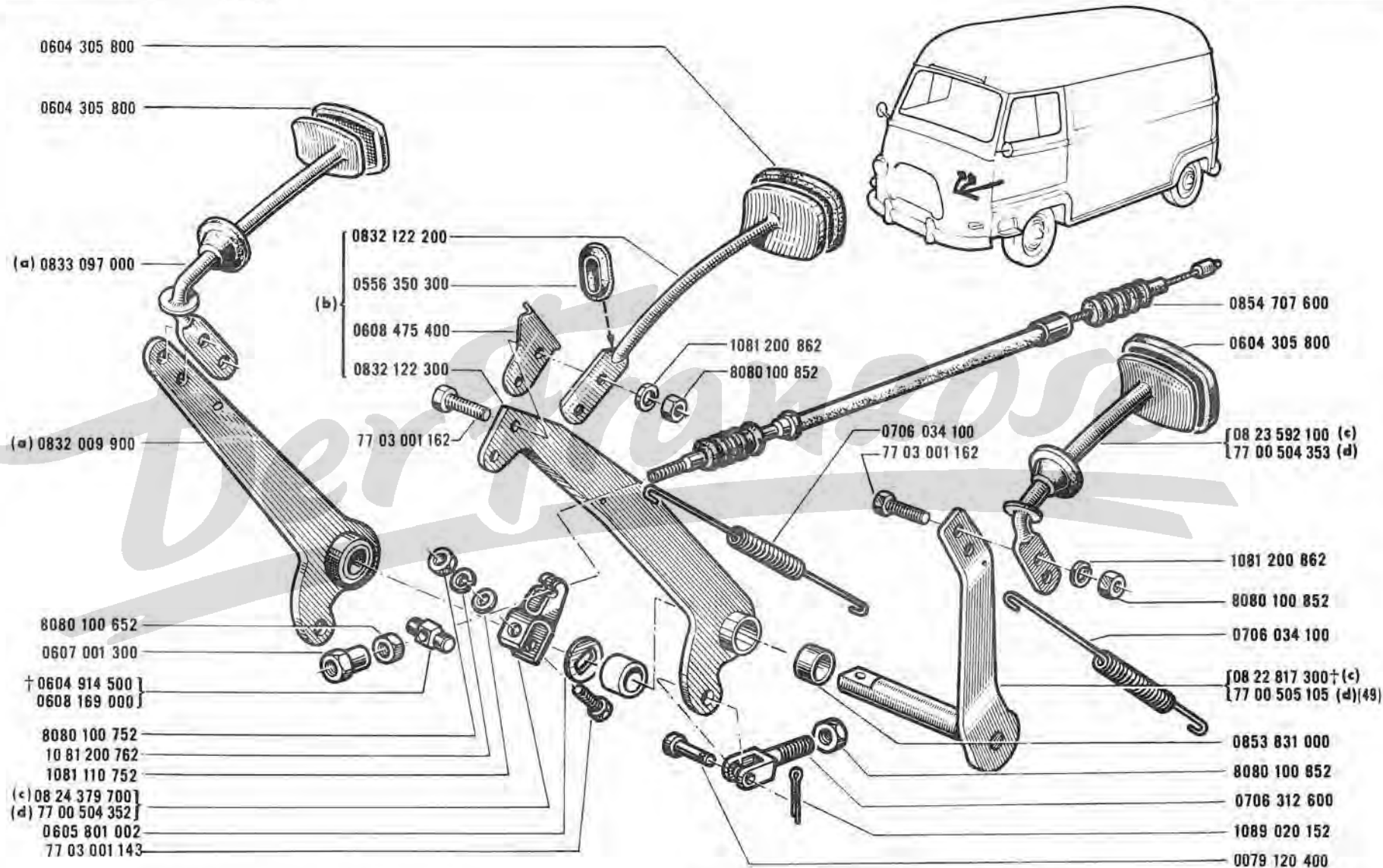

(a)	VEH n°	1	⇨	VEH n° 11966	☑ (1)
(b)	VEH n°	11967	⇨	VEH n° ...	☑ (1)
(c)	VEH n°	1	⇨	VEH n° 17428	
(d)	VEH n°	17429	⇨	VEH n° ...	

(1)	VEH n°	11915, 11921, 11934, 11948, 11949
		11952 ⇨ 11964
(49)	VEH n°	1 ⇨ VEH n° 17428
		± 77 00 504 353 -1-

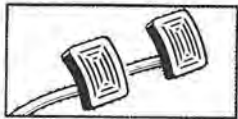

58.03

A P.R. 810



58.03

A P.R. 810

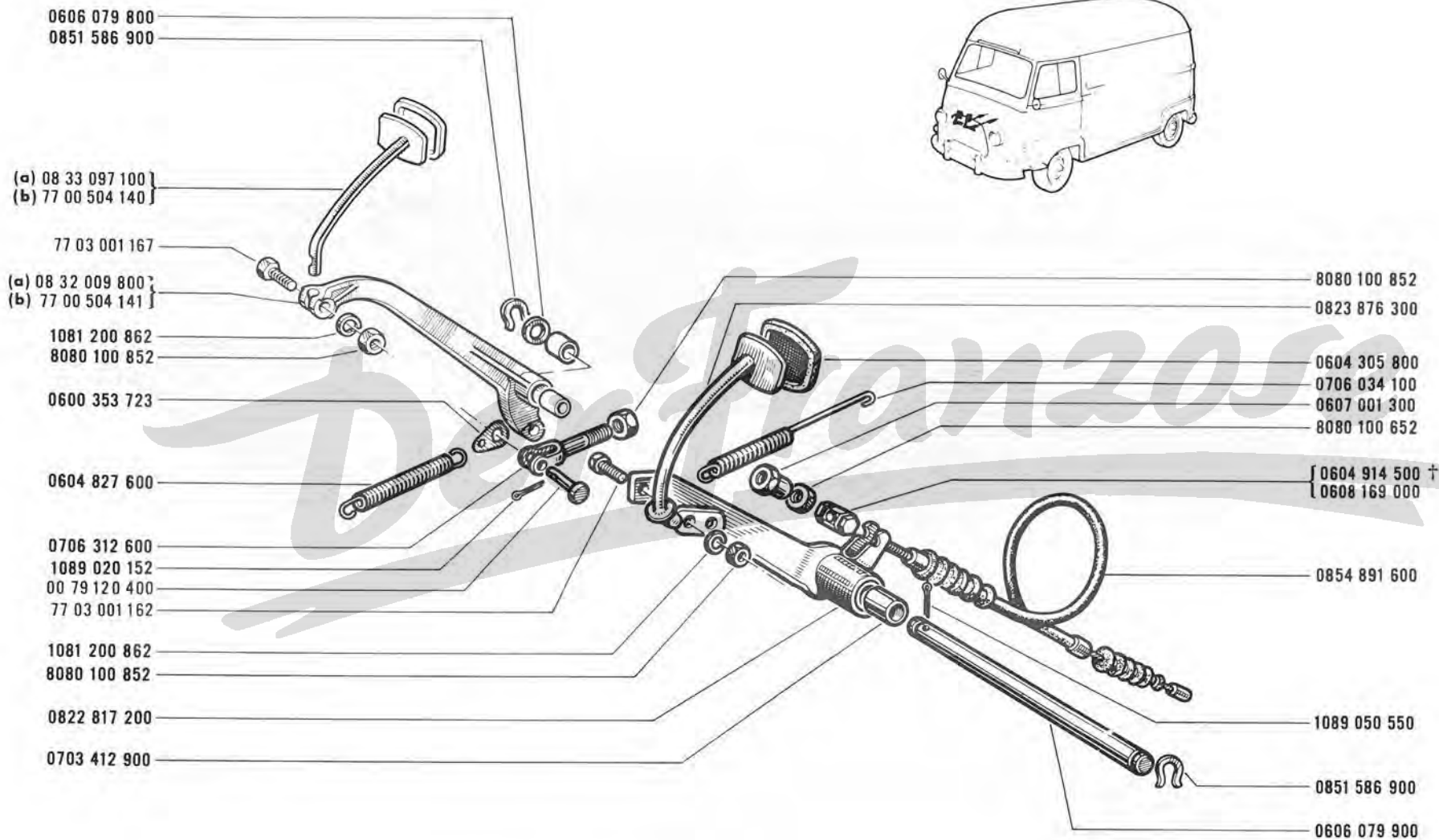

(a) VEH n° 1 ⇨ VEH n° 18522

(b) VEH n° 18523 ⇨ VEH n° ...

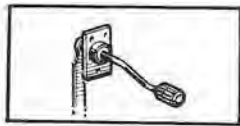

58.05

B P.R. 810

58.05

B P.R. 810



77 03 001 118
1081 200 662
0606 162 900

0984 236 700
0606 162 800

0605 921 100
77 03 001 122

0703 621 300
1088 020 150

0605 921 100 (a)
8080 100 652
0607 428 900 } (a)
0703 621 300
1088 020 150

0556 158 800 } (b)
0812 056 900 }
0854 837 900

0854 175 800
1081 110 852
0606 120 000

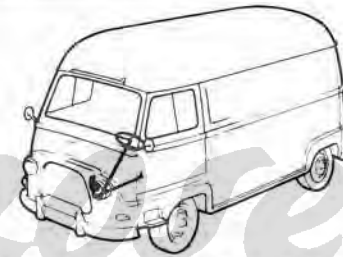

77 03 001 123

1081 200 662
1081 110 652
0605 573 700

0984 236 600

0605 573 500

0605 921 100

0555 405 100
0607 444 500

0703 621 300
1088 020 150
8080 100 652

0606 120 000
1081 110 852
0854 175 800
0605 921 100
0703 621 300
1088 020 150

0854 838 000
0549 034 700

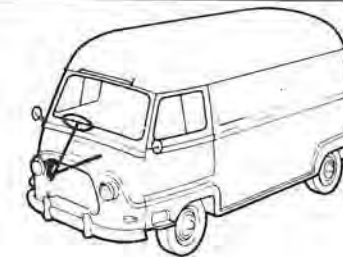

(a)	R 2134	/ 10/11/12/13/14/15/18/20/21/22/24/27/28/29/30/40/41/42/100/101/102/103
	R 2135	/ 120/121/122/130/140/200/201/202/204/207/211/220/230/231/240/241/242
(b)	R 2134, R 2135	/ 26/203

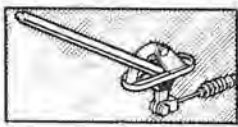

58.10

B P.R. 810



58.10

B P.R. 810

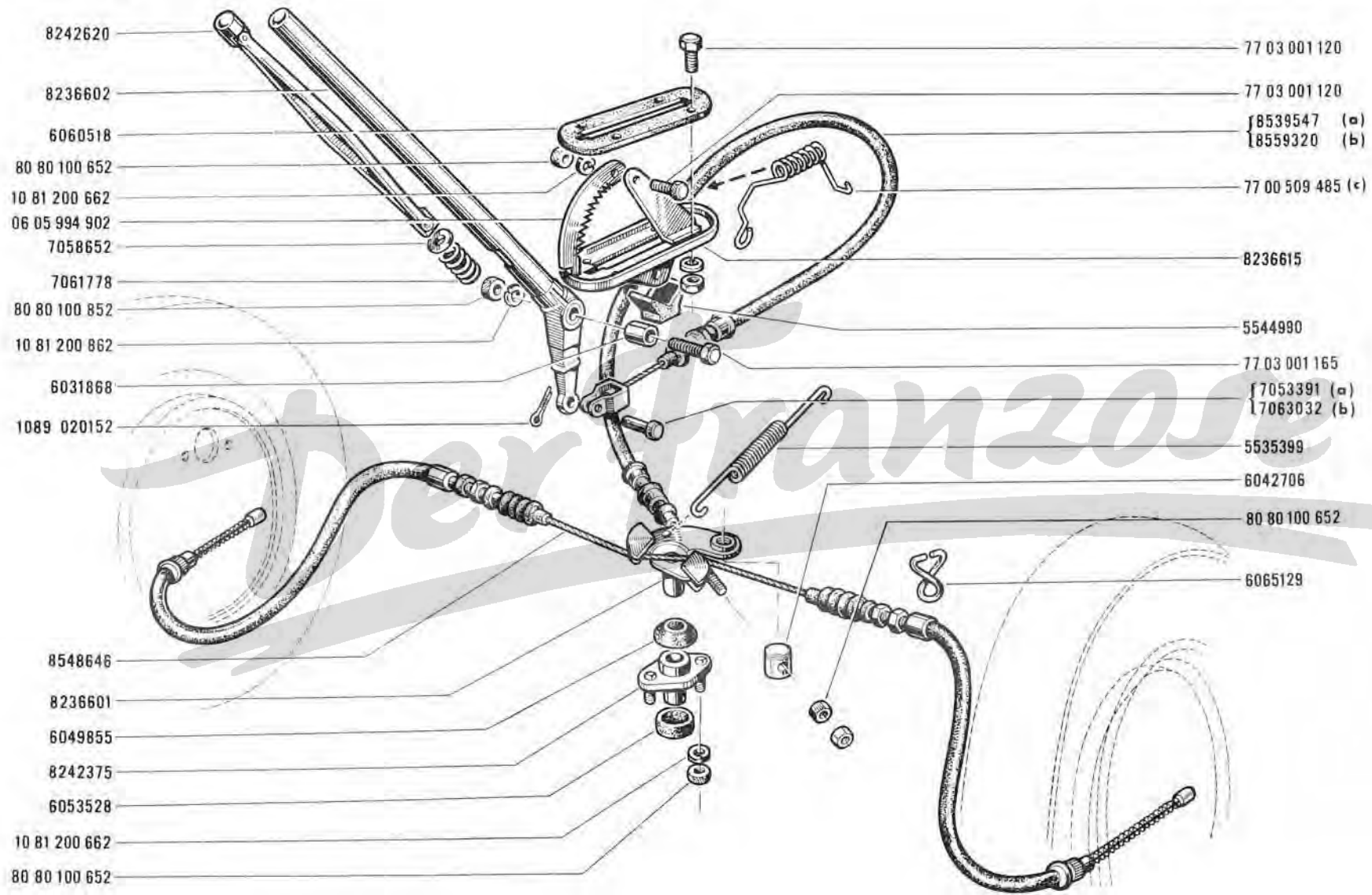
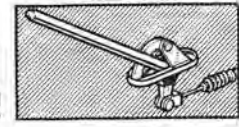

- 8242620
- 8236602
- 6060518
- 80 80 100 652
- 10 81 200 662
- 06 05 994 902
- 7058652
- 7061778
- 80 80 100 852
- 10 81 200 862
- 6031868
- 1089 020152
- 8548646
- 8236601
- 6049855
- 8242375
- 6053528
- 10 81 200 662
- 80 80 100 652

- 77 03 001 120
- 77 03 001 120
- 8539547 (a)
- 8559320 (b)
- 77 00 509 485 (c)
- 8236615
- 5544990
- 77 03 001 165
- 7053391 (a)
- 7063032 (b)
- 5535399
- 6042706
- 80 80 100 652
- 6065129

(a) VEH n° 1 ⇨ VEH n° 9736

(b) VEH n° 9737 ⇨ VEH n° ...

(c) VEH n° 16402 ⇨ VEH n° ... [2]

(2) VEH n° 16389,16396

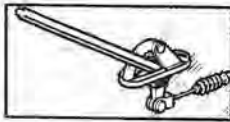

58 15

B P.R. 810



58.15

B P.R. 810

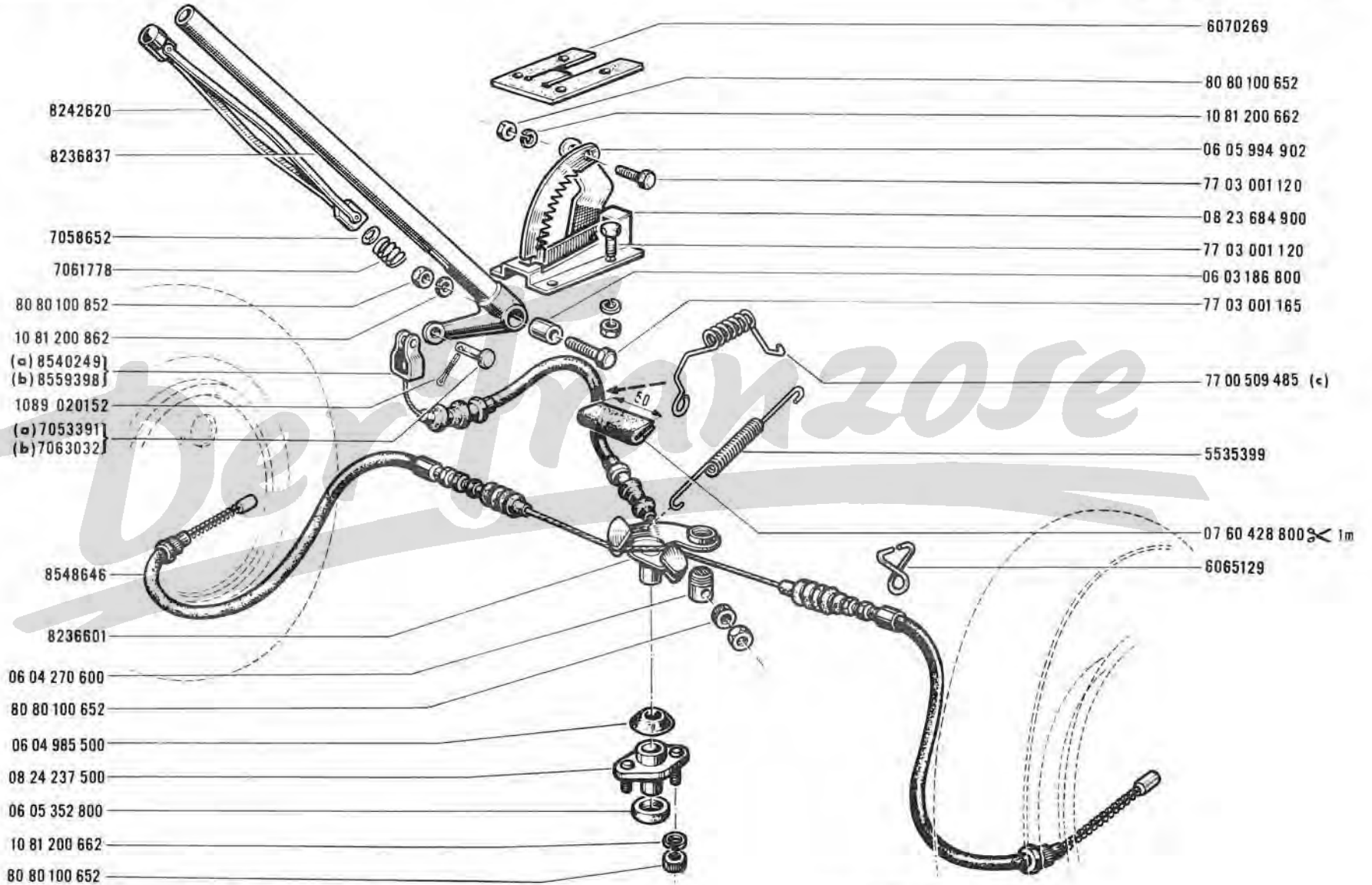
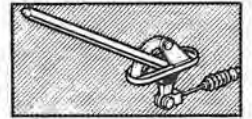

(a) VEH n° 1 ⇨ VEH n° 9736

(b) VEH n° 9737 ⇨ VEH n° ...

(c) VEH n° 16402 ⇨ VEH n° ... (2)

(2) VEH n° 16389,16396

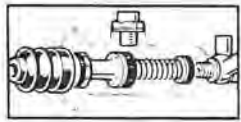

58.20

B P.R. 810

58.20

B P.R. 810

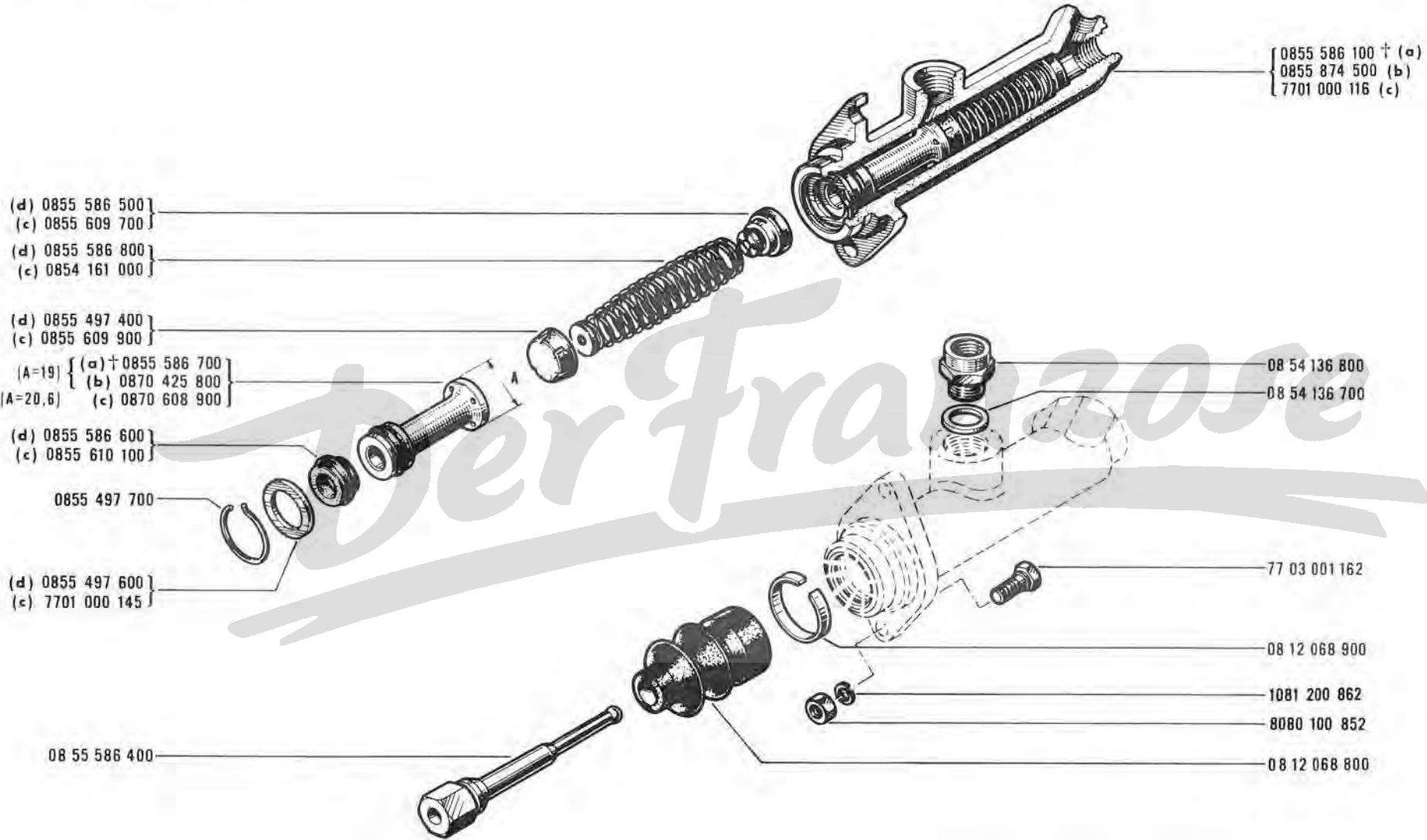
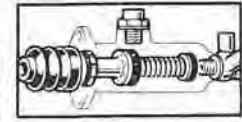

(a)	VEH n°	1	⇨	VEH n°	4888
(b)	VEH n°	4889	⇨	VEH n°	11966
	VEH n°	4889	⇨	VEH n°	18522

(c)	VEH n°	11967	⇨	VEH n°	...
	VEH n°	18523	⇨	VEH n°	...
(d)	VEH n°	1	⇨	VEH n°	11966
	VEH n°	1	⇨	VEH n°	18522

(1)	VEH n°	11915, 11921, 11934, 11948, 11949,
		11952 ⇨ 11964

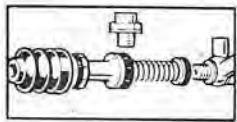

58.22

B P.R. 810

58.22

B P.R. 810

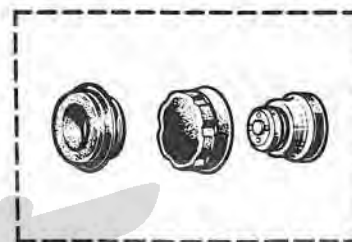
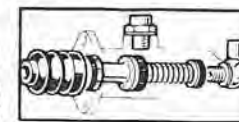

{ 0855 586 300 (a)
0855 610 300 (b)

Der Franzose

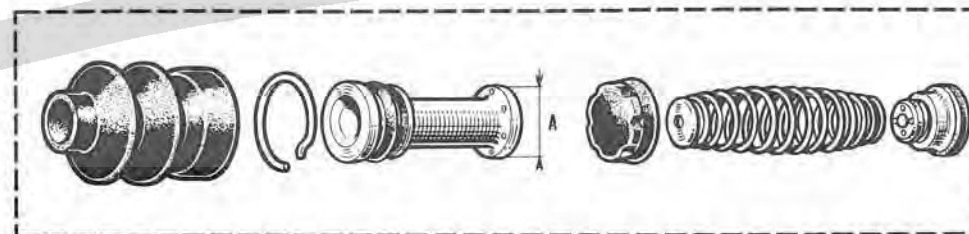

{ 0855 586 200[†] } (a) (A=19)
0870 426 400 }
0870 608 800 (b) (A=20,6)

(a)	VEH n°	1	⇨	VEH n° 11966	☒ [1]
	VEH n°	1	⇨	VEH n° 18522	
(b)	VEH n°	11967	⇨	VEH n°...	☒ [1]
	VEH n°	18523	⇨	VEH n°...	

[1] VEH n° 11915,11921,11934,11948,11949,11952 ⇨ 11964

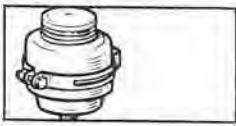

58.25

B P.R. 810

58.25

B P.R. 810

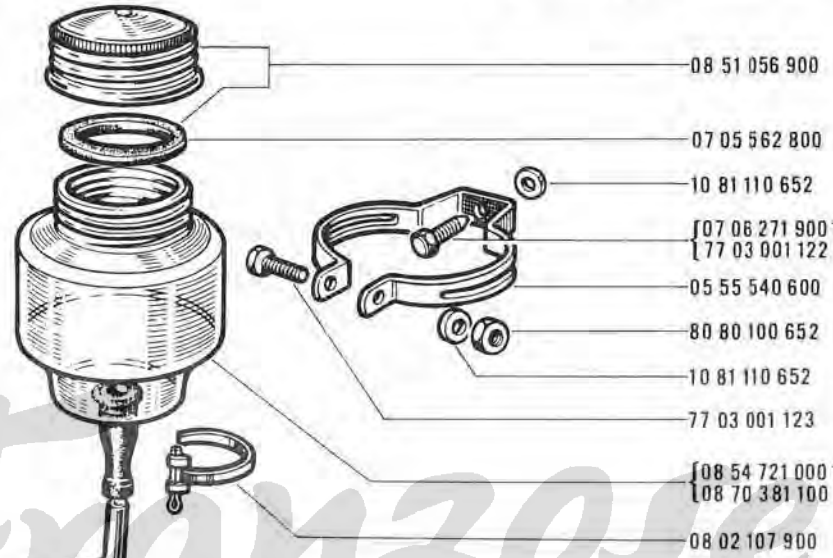

(▶◀=4000) 3801824000

08 11 936 900

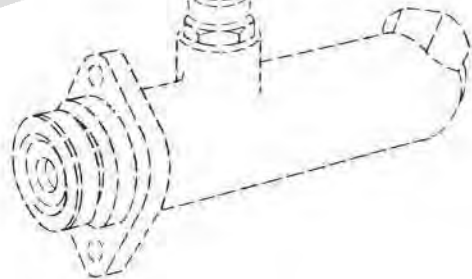

Der Franzose

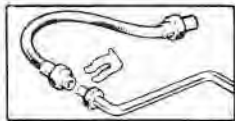

58.30

B P.R. 810

- (a) † 06 03 532 400
- (b) † 06 08 209 900
- 06 08 209 902

08 23 747 400

∅ < 1m 07 60 472 700

08 33 097 800

05 52 676 400

- (a) † 06 03 532 400
- (b) † 06 08 209 900
- 06 08 209 902

∅ < 1m 07 60 472 700

- 08 23 739 100
- 08 23 740 000

∅ < 1m 07 60 472 700

- 08 23 739 300
- 08 23 740 100

- (a) † 06 03 532 400
- (b) † 06 08 209 900
- 06 08 209 902

- (a) † 0823 878 100
- (b) 7701 000 244

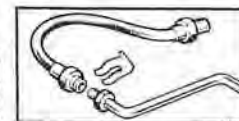
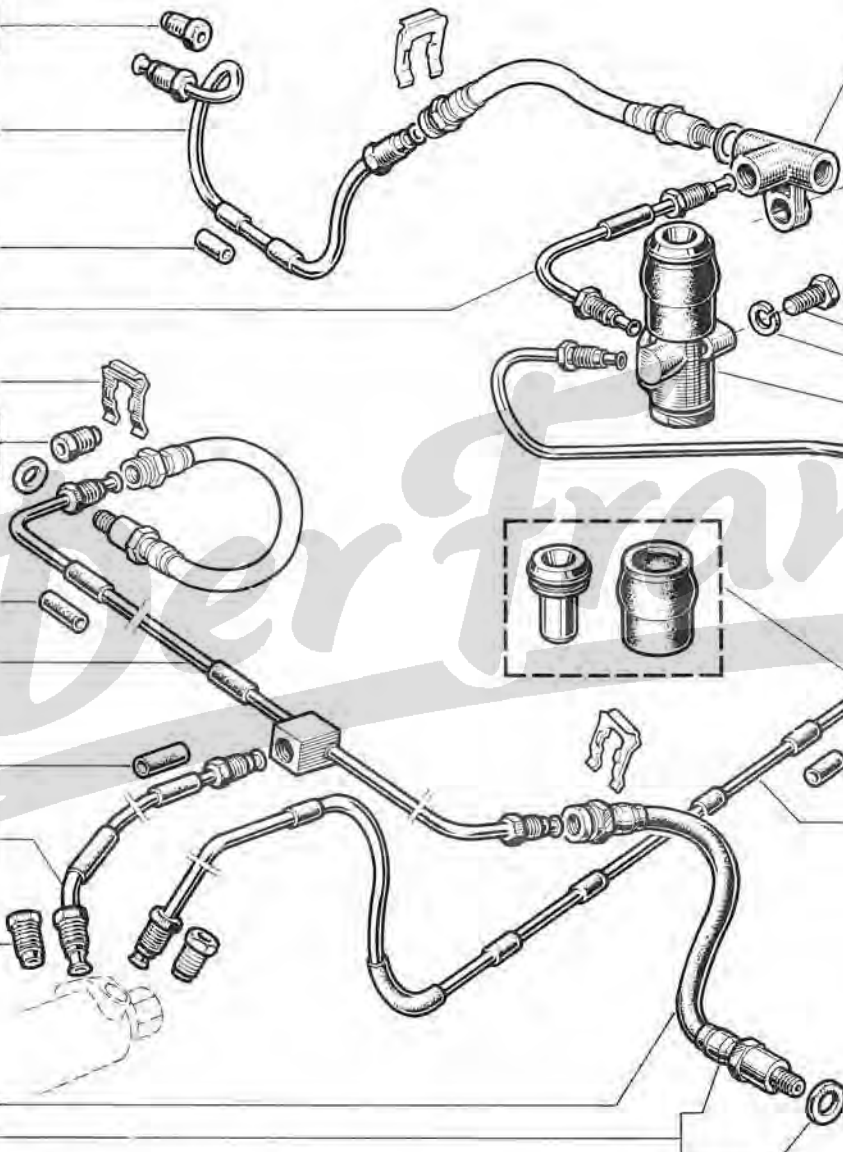

58.30

B P.R. 810

- 0554 766 600 † (a)
- 10556 276 800 (b)
- 1081 110 862

77 03 001 162

1081 200 862

0706 260 500

0823 878 200 † (a)

7701 000 245 (b)

0552 676 400

- 06 03 532 400 † (a)
- 06 08 209 900 † (b)
- 06 08 209 902

77 03 001 368

1081 200 762

0855 738 800

07 60 472 700 ∅ < 1m

0823 739 500

08 70 284 300

07 60 472 700 ∅ < 1m

- 08 33 097 900
- 08 33 098 000

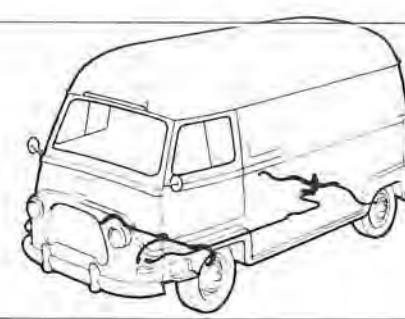

07 06 260 500

(a) VEH n° 1 ⇨ VEH n° 11966 [1]

(b) VEH n° 11967 ⇨ VEH n° ... [1]

[1] VEH n° 11915, 11921, 11934, 11948, 11949, 11952 ⇨ 11964

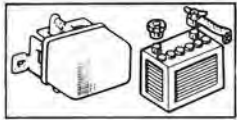

60.01

B P.R. 810

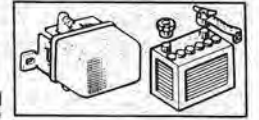

60.01

B P.R. 810

{2} (a) 08 54 775 300

{1} [(c) 08 54 774 100]
[(d) 08 54 807 900]

80 80 100 552

10 81 350 552

10 81 350 552

80 80 100 552

{3} (b) { 08 33 080 600
08 54 233 000

08 54 233 000

08 54 221 700

80 80 100 852

10 81 350 852

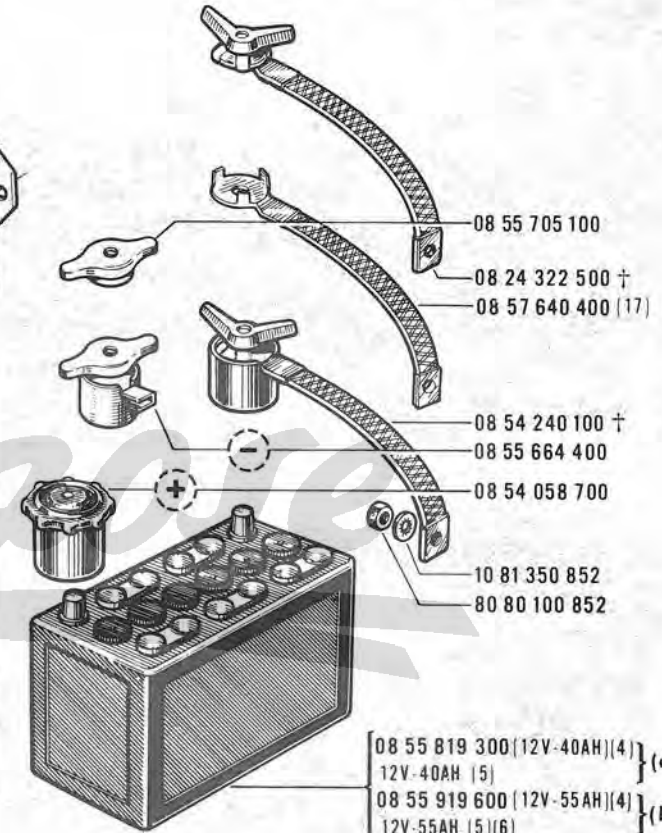
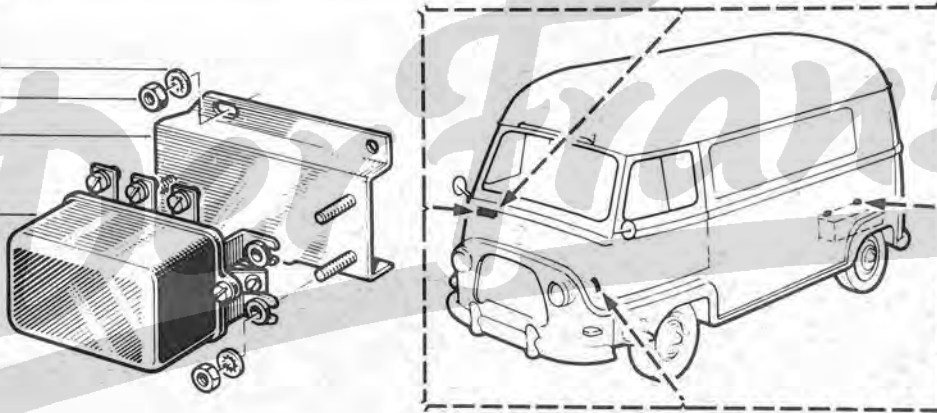
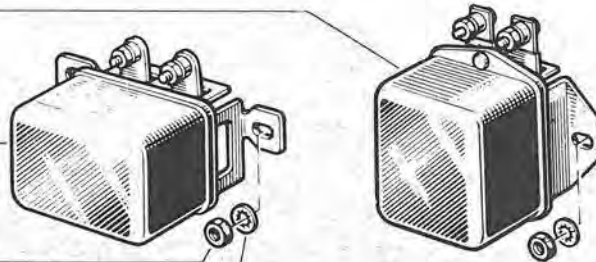

08 55 705 100

08 24 322 500 †

08 57 640 400 (17)

08 54 240 100 †

08 55 664 400

08 54 058 700

10 81 350 852

80 80 100 852

{ 08 55 819 300 (12V-40AH) (4) } (a)
12V-40AH (5)
08 55 919 600 (12V-55AH) (4) } (b)
12V-55AH (5) (6)

(a) R 2134, R 2135	/ 10/11/12/13/14/15/18/20/21/22/24/26/27/28/29/70/80/81/84/86/88/89/100/101/102/103 120/121/122/130/200/201/202/203/204/207/211/230/700/800/801/803/807/810/811/220/231
(b) R 2134, R 2135	/ 30/40/41/42/140/240/241/242
(c) R 2134, R 2135	/ 10/11/12/13/14/15/18/70/100/101/102/120/121/122/130/700/103
(d) R 2134, R 2135	/ 20/21/22/24/26/27/28/29/80/81/84/86/88/89/200/201 202/203/204/207/211/800/801/803/807/810/811/220

(1)	7267-12V	7272-12V
(2)	G 10C 14-12V	G 10C 58-12V
(3)	LI/GG 240/12/2400/AR/21MR	
(4)	TUDOR	
(5)	FULMEN	
(6)	TEM	
(17)	⊥ 08 55 705 100 -1-	

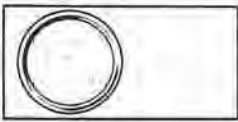

60.05.1

B P.R. 810

R.2134 / 41/240 60.07
R.2135

60.05.1

B P.R. 810

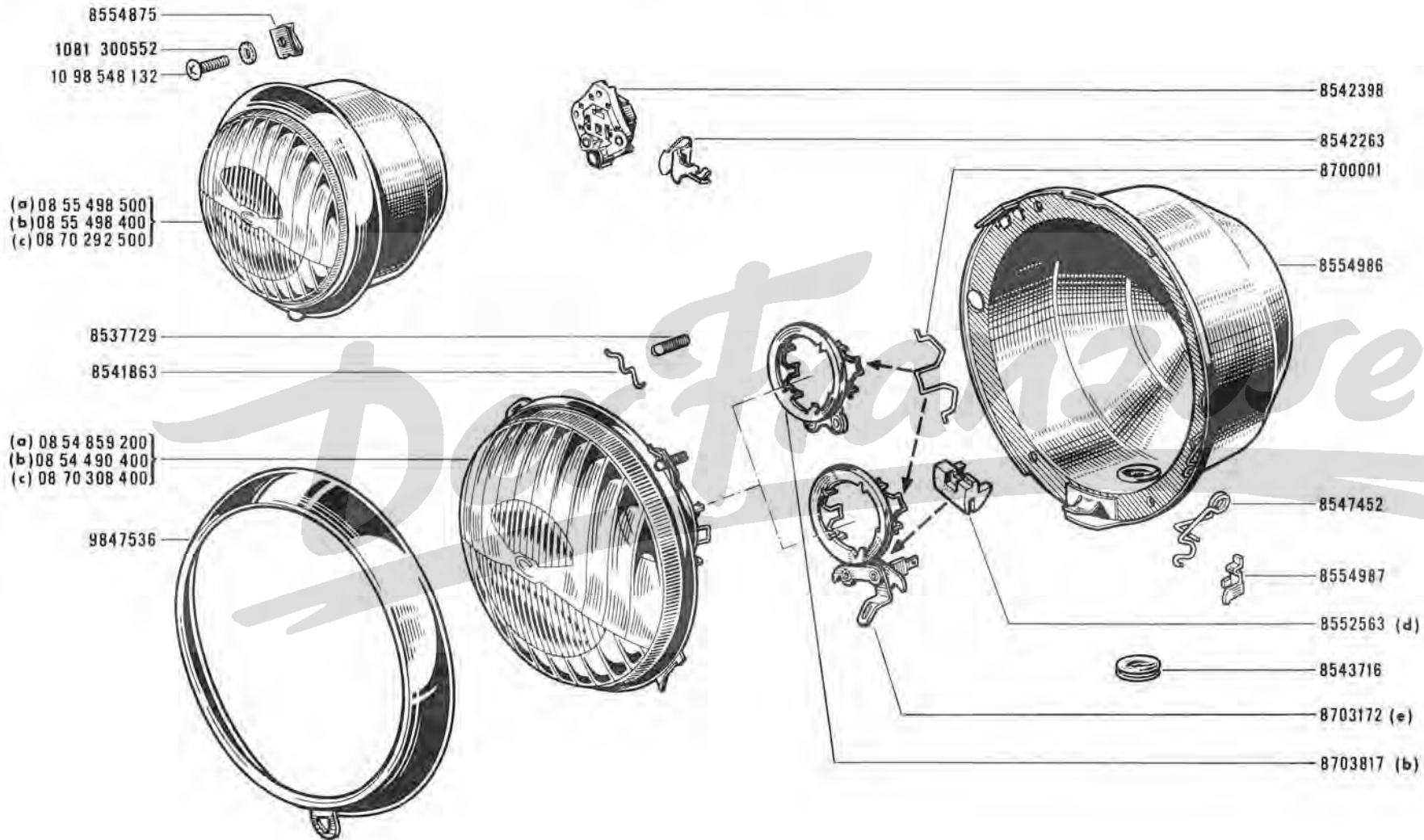

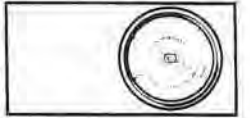

(a)	R.2134 /	12/14/18/120/121/130
	R.2135 /	
(b)	R.2134 /	10/11/13/15/20/21/22/24/26/27/28/29/30/40/42/70/89/100/101/102
	R.2135 /	103/122/140/200/201/202/203/204/207/211/220/230/231/241/242/700
		80/81/84/86/88:VEH n° 1 ⇨ VEH n° 2839
(c)	R.2134 /	800/801/803/807/810/811
	R.2135 /	80/81/84/86/88:VEH n° 2840 ⇨ VEH n° . . .
(d)	R.2134 /	10/11/13/15/20/21/22/24/26/27/28/29/30/40/42/70/80/81/84/86/88
	R.2135 /	89/100/101/102/103/122/140/200/201/202/203/204/207/211/220/230
		231/241/242/700/800/801/803/807/810/811
(e)	R.2134 /	12/14/18/120/121/130/800/801/803/807/810/811
	R.2135 /	80/81/84/86/88:VEH n° 2840 ⇨ VEH n° . . .



60.07
B P.R. 810

R 2134 / 41/240
R 2135 /

60.07
B P.R. 810



1081 300552
10 98 548 132

8554875

08 54 541 600

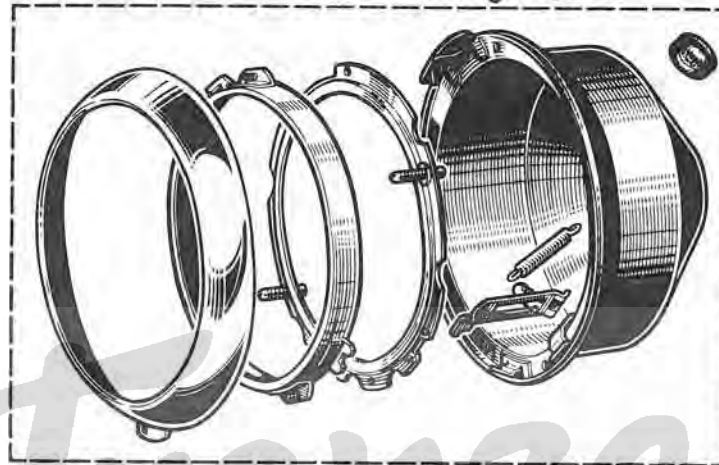

08 54 535 100

8542398
8542263
10 98 528 102
8543611

8543716

8546179

8546180

8543699

8543687

8543608

8543610

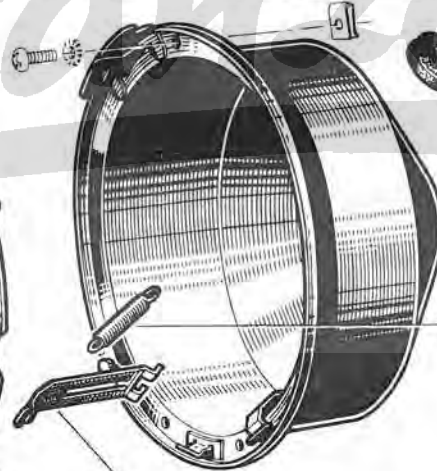
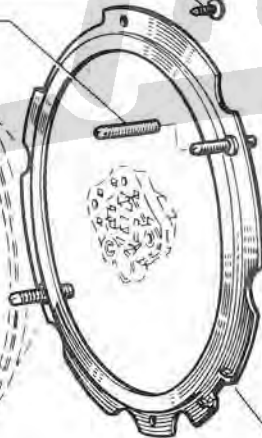
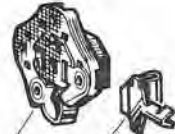
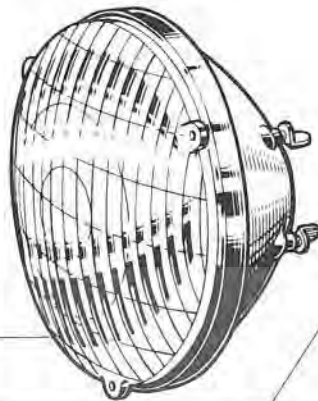



60.10
B P.R. 810

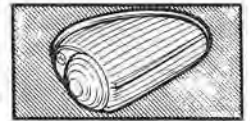

60.10
B P.R. 810

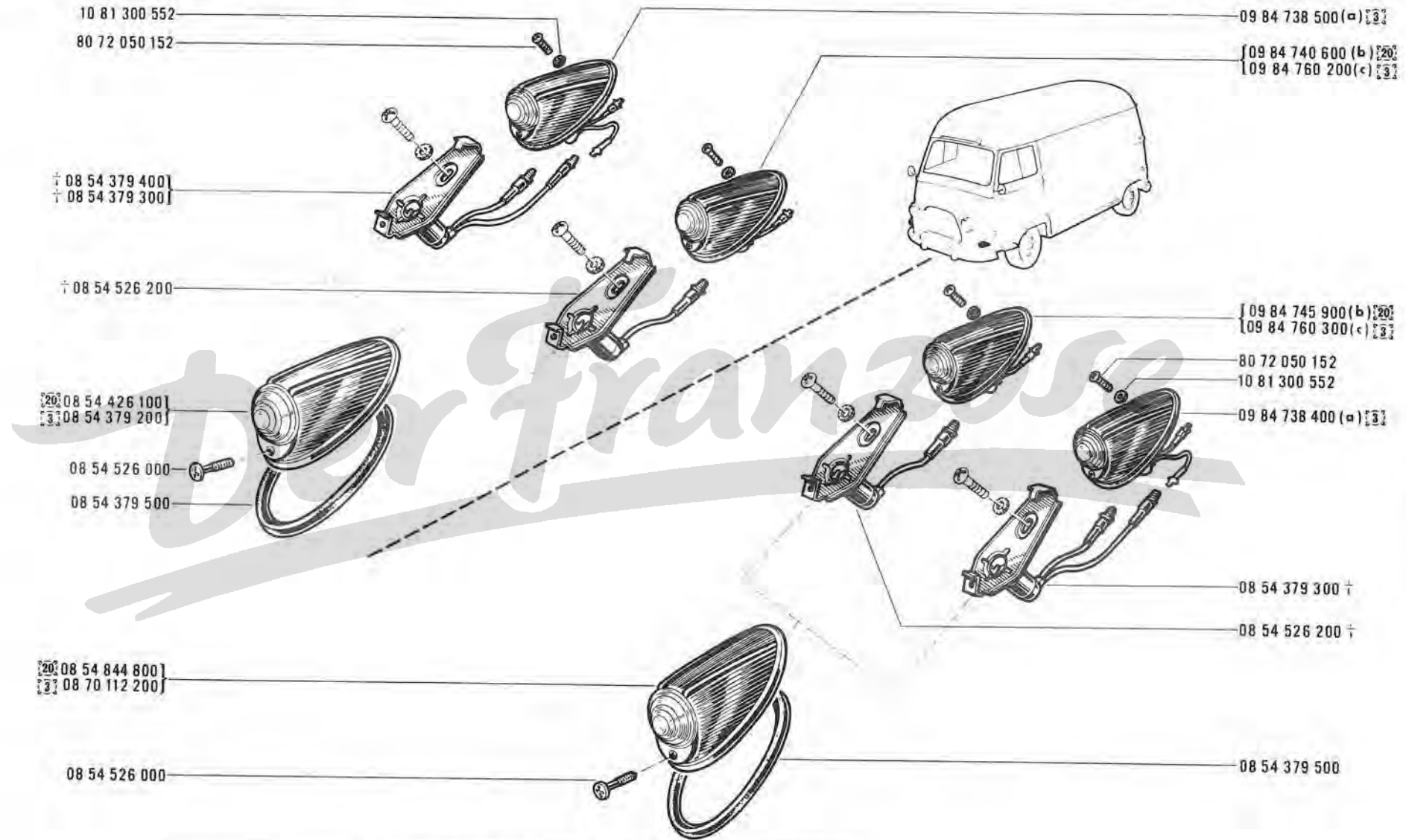

(a) R.2134, R.2135	/ 10/11/13/20/21/22/24/26/27/28/29/30/40/41/42/100/101/102/103 140/200/201/202/203/204/207/211/220/230/231/240/241/242
	15 .. VEH n° 1 ⇨ VEH n° 6364
(b) R.2134, R.2135	/ 12/14/18/80/81/84/86/88/89/120/121/130/800/801/803/807/810/811
(c) R.2134, R.2135	/ 70/122/700
	15 .. VEH n° 6365 ⇨ VEH n°



60.13
B P.R. 810

R.2134 / 13/70/102/122/700
R.2135 / 15 VEH n° **6365** ⇨ VEH n°

60.13
B P.R. 810

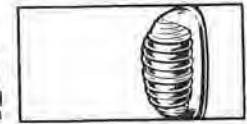

08 54 686 300

08 54 875 300

08 54 875 400

80 70 040 082

08 54 875 200

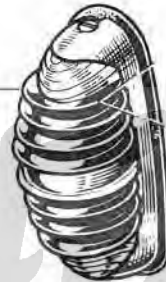
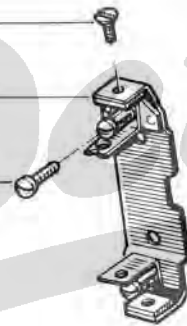

10 81 300 452

10 98 535 162

08 54 875 500

Dorfranzose



60.25
B P.R. 810

R 2134
R 2135

/10/11/20/21/22/24/26/27/28/29/30/40/41/42/100/101/103
140/200/201/202/203/204/207/211/220/230/231/240/241/242
15 : VEH n° 1 ⇨ VEH n° 6364

60.25
B P.R. 810

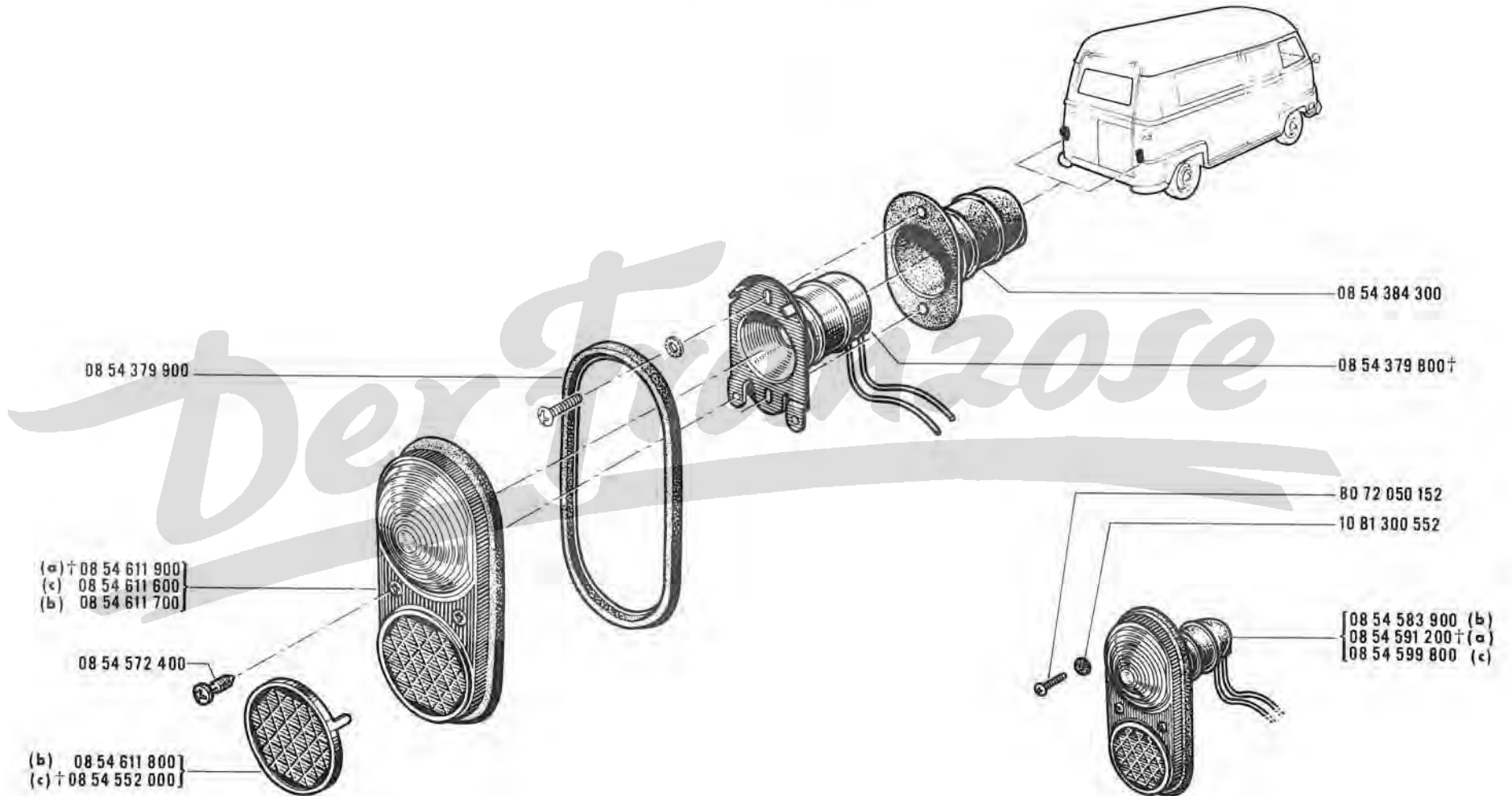

(a) R 2134, R 2135 /41/240

(b) R 2134, R 2135 /11/101/103

(c) R 2134, R 2135 /10/20/21/22/24/26/27/28/29/30/40/41/42/100/140/200/201
202/203/204/207/211/220/230/231/240/241/242

15 : VEH n° 1 ⇨ VEH n° 6364



60.28

B P.R. 810

R.2135 / 13/70/80/81/84/86/88/89/102/122
700/800/801/803/807/810/811
R.2134 / 15 VEH n° 6365 ⇨ VEH n° . . .

60.28

B P.R. 810



- 8080 100452
- 1081 300452
- 8072 050122
- 8061 050102
- 08 54 555 200
- † 08 54 555 100
- 08 70 340 100
- 08 70 340 200
- 08 51 759 900
- † 08 54 555 000
- † 08 54 575 200
- 16 08 53 584 372
- 08 53 584 200
- 08 51 759 900
- 12 08 53 584 389
- 08 53 584 200
- † 08 54 555 300
- 08 53 618 400

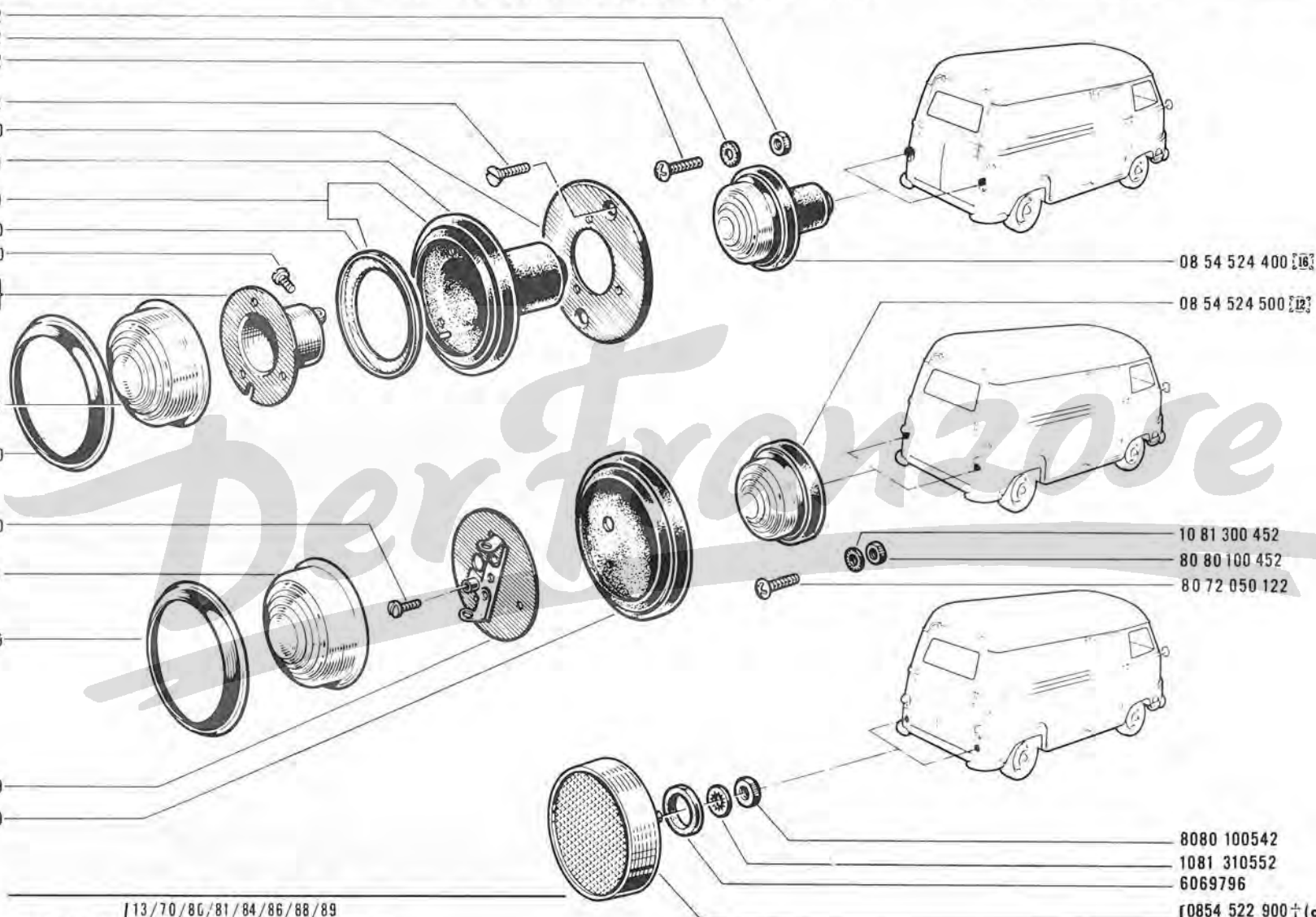

- 08 54 524 400 [16]
- 08 54 524 500 [12]
- 10 81 300 452
- 80 80 100 452
- 80 72 050 122
- 8080 100542
- 1081 310552
- 6069796
- [0854 522 900 † (a)
- [0855 946 700 (b)

(a)	R 2134	13/70/80/81/84/86/88/89	
	R 2135	15 VEH n° 6365 ⇨ VEH n° . . .	
(b)	R 2134	102/700/800/801	VEH n° 10046 ⇨ VEH n° . . .
	R 2135	803/807/810/811	122



60.31

B P.R. 810

R.2134 / 12/14/18/120/121/130
R.2135

60.31

B P.R. 810

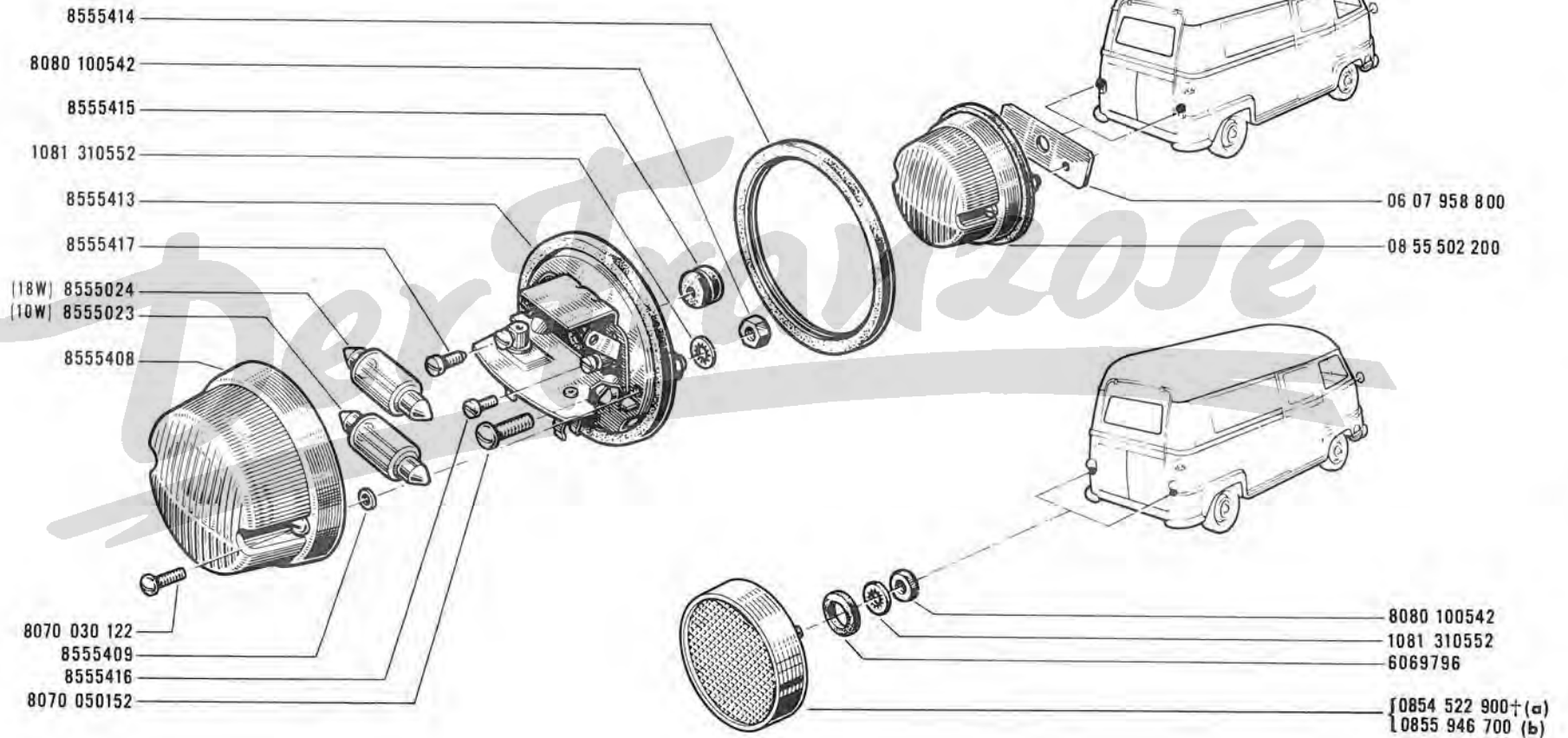

(a) R 2134, R 2135	/ 12/14/18	1 ⇨ VEH n° 10045
(b) R 2134, R 2135	/ 120/121/130 VEH n° 10046	⇨ VEH n° . . .



60.35

B P.R. 810



R 2134 / 10/20/100/200

R 2135 / 102 : VEH n° 9047 ⇨ VEH n° . . .

60.35

B P.R. 810

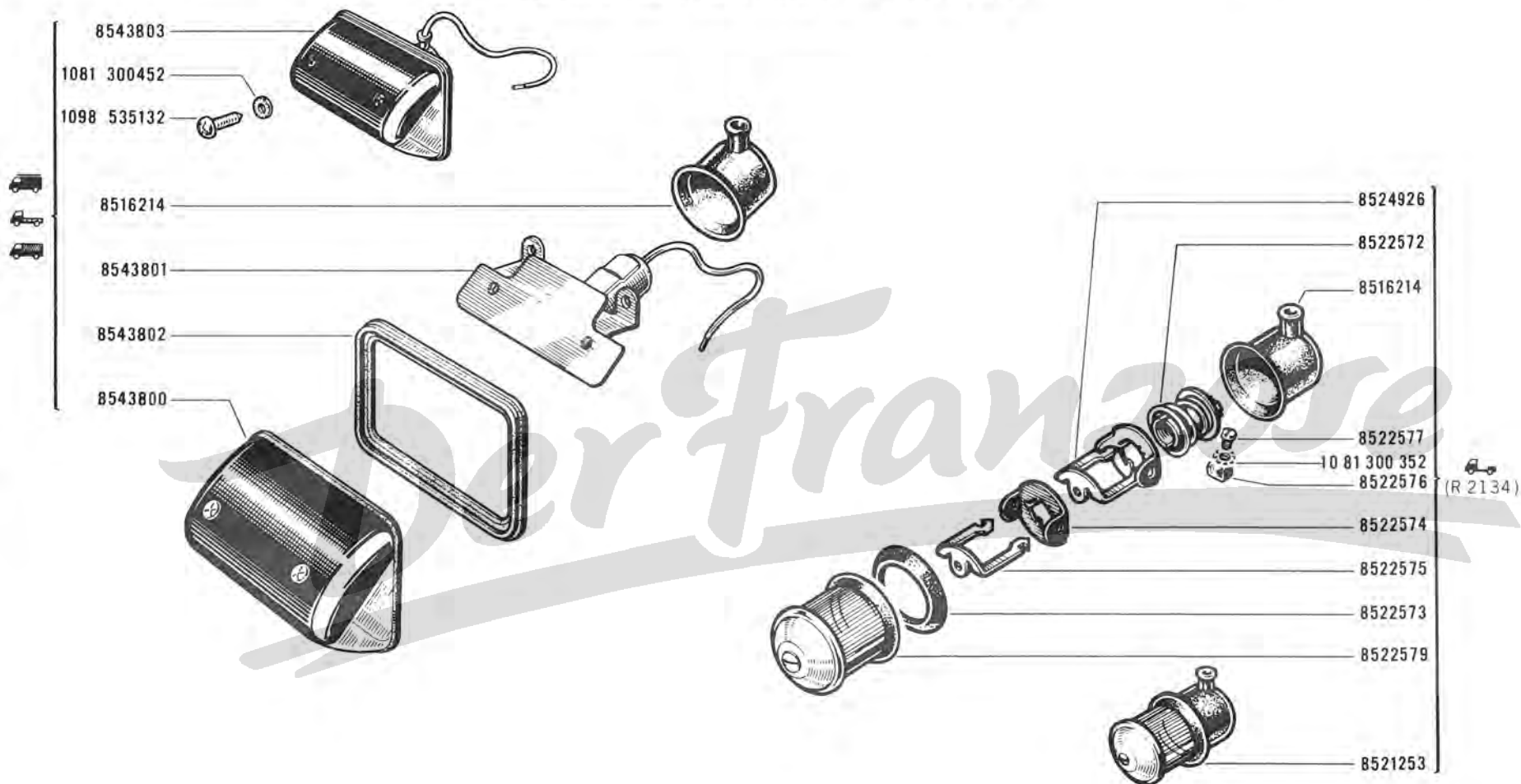



60.37

B P.R. 810



(a)

60.37

B P.R. 810



80 80 120 550

10 81 300 552

(b) 08 54 961 264
(c) 08 54 653 664
(d) 08 55 135 364

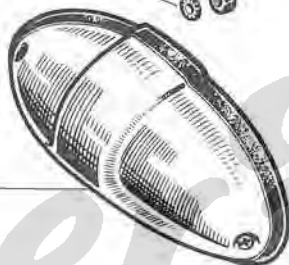

08 54 674 300

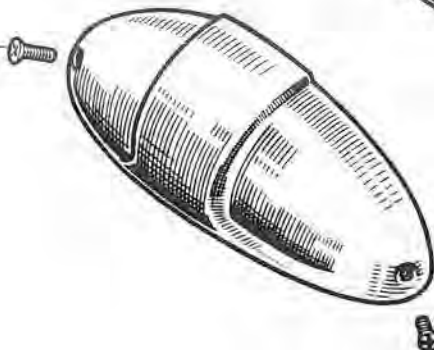

08 54 674 100

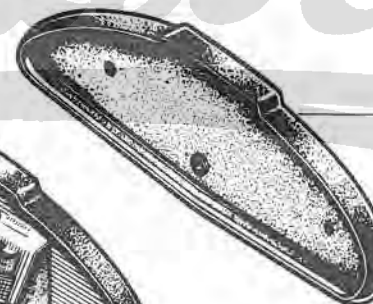

08 54 673 900

08 55 273 200 (b)
08 55 273 300 (c)
08 55 208 000 (d)

(a)	R 2134	/11/12/14/15/18/21/22/24/26/27/28/29/30/40/41/42/70/80/81/84
	R 2135	86/88/89/101/103/120/121/122/130/140/201/202/203/204/207
		211/220/230/231/240/241/242/700/800/801/803/807/810/811
		13/102 : VEH n° 1 ⇨ VEH n° 9046
(b)	R 2134, R 2135	/12/14/18/120/121/130

(c)	R 2134	/11/15/21/22/24/26/27/28/29/30/40/41/42/70/80/81/84/86
	R 2135	88/89/101/103/122/140/201/202/203/204/207/211/220
		230/231/240/241/242/700/800/801/803/807/810/811
(d)	R 2134, R 2135	/13/102 : VEH n° 1 ⇨ VEH n° 9046

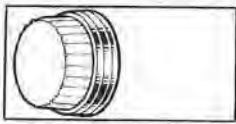

60.40
B P.R. 810

R.2134 / 41/240
R.2135 / 41/240

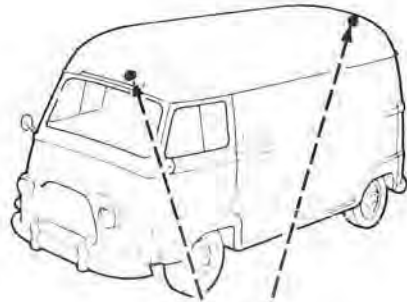



08 53 675 400

10 98 535 192

† 08 53 705 100

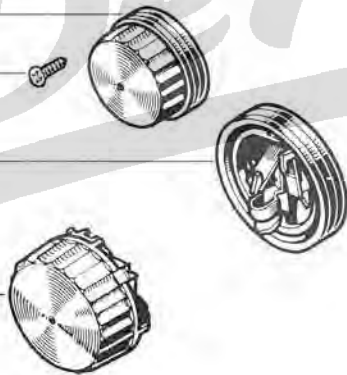
08 53 578 300



R 2134 }
R 2135 }  /41/240

60.40
B P.R. 810

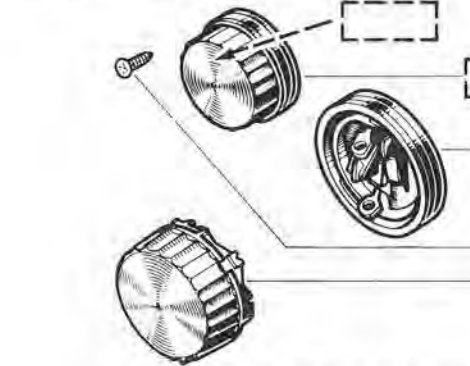
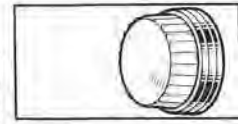

HUSSEX — 08 53 514 800

08 53 659 900 †

10 98 535 192

08 53 578 300

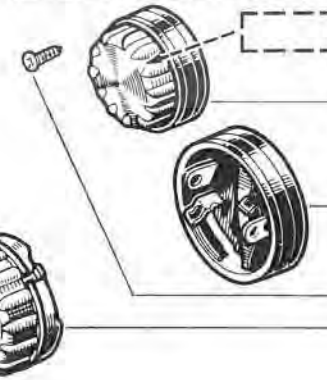
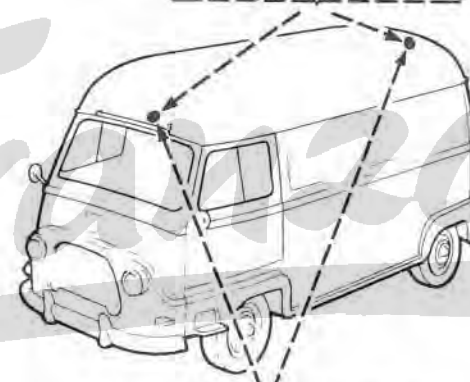

LMP — 08 52 487 200

08 53 561 900 †

10 98 535 192

08 53 561 800

Der Franzose

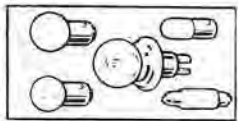

60.45

B P.R. 810

60.45

B P.R. 810

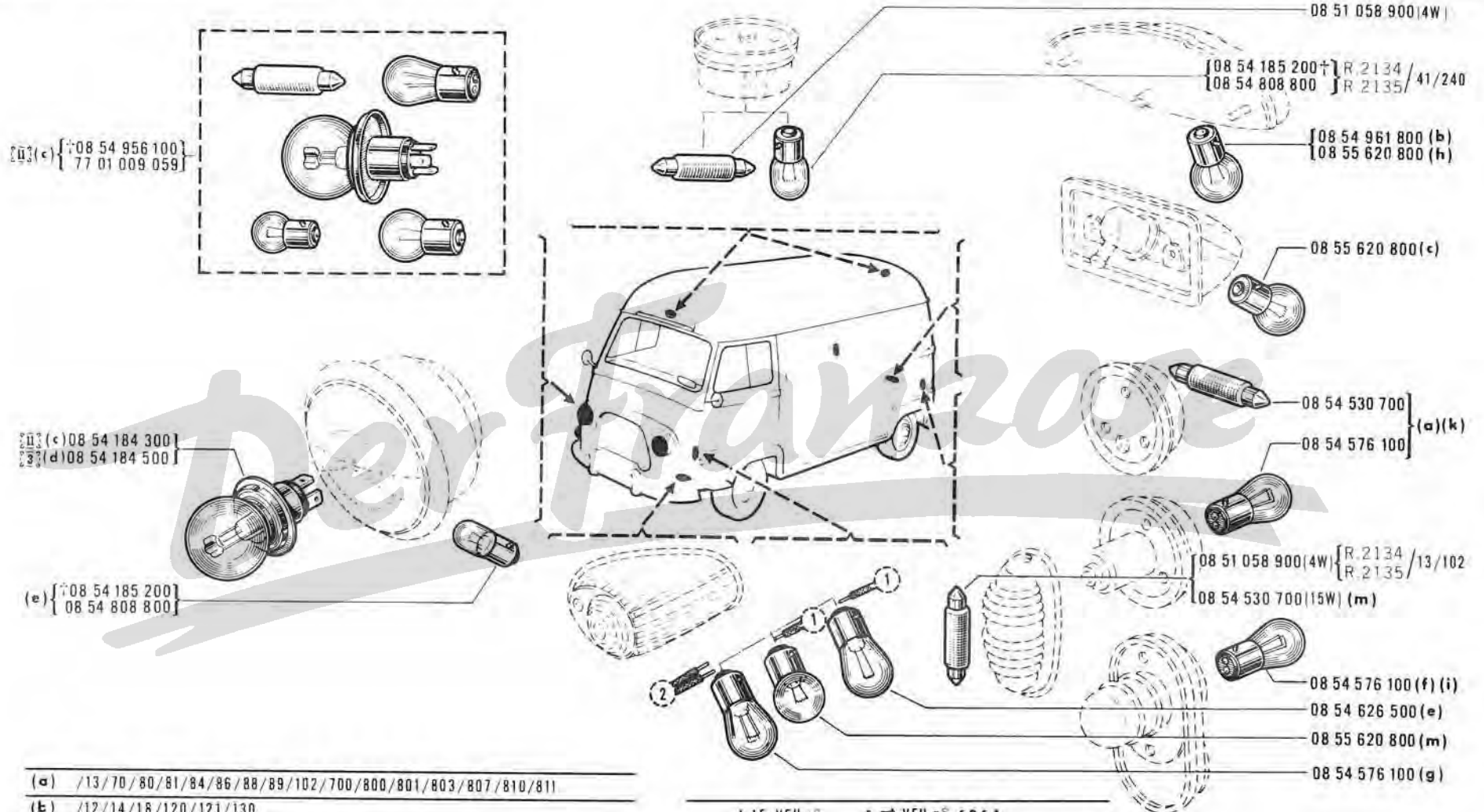
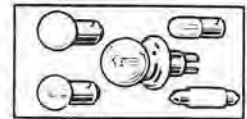

(a)	/13/70/80/81/84/86/88/89/102/700/800/801/803/807/810/811
(b)	/12/14/18/120/121/130
(c)	/10/20/100/200
(d)	/11/12/13/14/15/18/21/22/24/26/27/28/29/30/40/41/42/70/80/81 84/86/88/89/101/102/103/120/121/122/130/140/201/202/203 204/207/211/220/230/231/240/241/242/700/800/801/803/807/810/811
(e)	/12/14/18/80/81/84/86/88/89/120/121/130 800/801/803/807/810/811
(f)	/10/11/20/21/22/24/26/27/28/29/30/40/41/42/100/101/103 140/200/201/202/203/204/207/211/220/230/231/240/241/242

(g)	15 VEH n° 1 ⇨ VEH n° 6364 10/11/13/20/21/22/24/26/27/28/29/30/40/41 42/100/101/102/103/140/200/201/202/203/204 207/211/220/230/231/240/241/242
(h)	11/13/15/21/22/24/26/27/28/29/30 40/41/42/70/80/81/84/86/88/89/101 102/103/122/140/201/202/203/204 207/211/220/230/231/240/241/242 700/800/801/803/807/810/811

(i)	/15 VEH n° 1 ⇨ VEH n° 6364
(k)	/15 VEH n° 6365 ⇨ VEH n° ... 122
(m)	/15 VEH n° 6365 ⇨ VEH n° ... 70/122/700



60.55

B P.R. 810

{ R.2134 } VEH n° 1 ⇨ VEH n° 6364
{ R.2135 }

60.55

B P.R. 810



08 53 515 400

08 53 525 800

08 53 515 100

80 70 040 062

08 53 515 000

08 53 863 600

08 53 863 500

80 70 040 082

08 53 863 900

10 81 300 852

80 80 100 842

80 80 100 442

77 03 001 160

08 54 331 200

10 81 300 852

80 80 100 852

KM4 12V A

08 54 129 000

08 54 218 200

80 80 100 442

10 81 300 852

80 80 100 842

77 03 001 160

08 53 818 200

10 81 300 852

80 80 100 852

PHF 12V A

08 54 357 500

Der Franzose

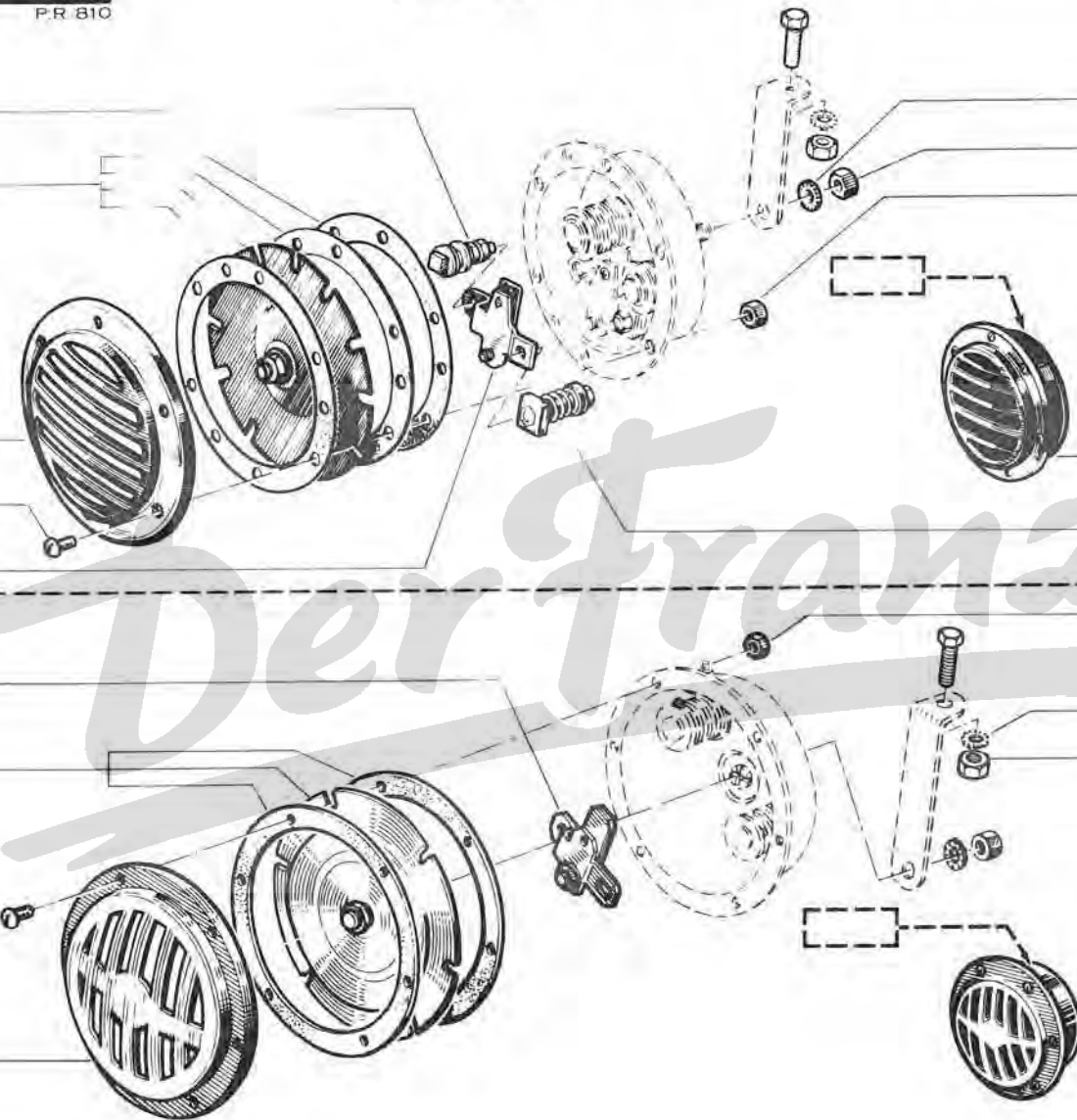

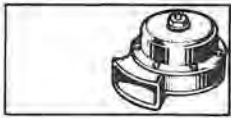

60.58

B P.R. B10

R.2134 / 10/20 : VEH n° 1 ⇨ VEH n° 6364
R.2135

60.58

B P.R. B10

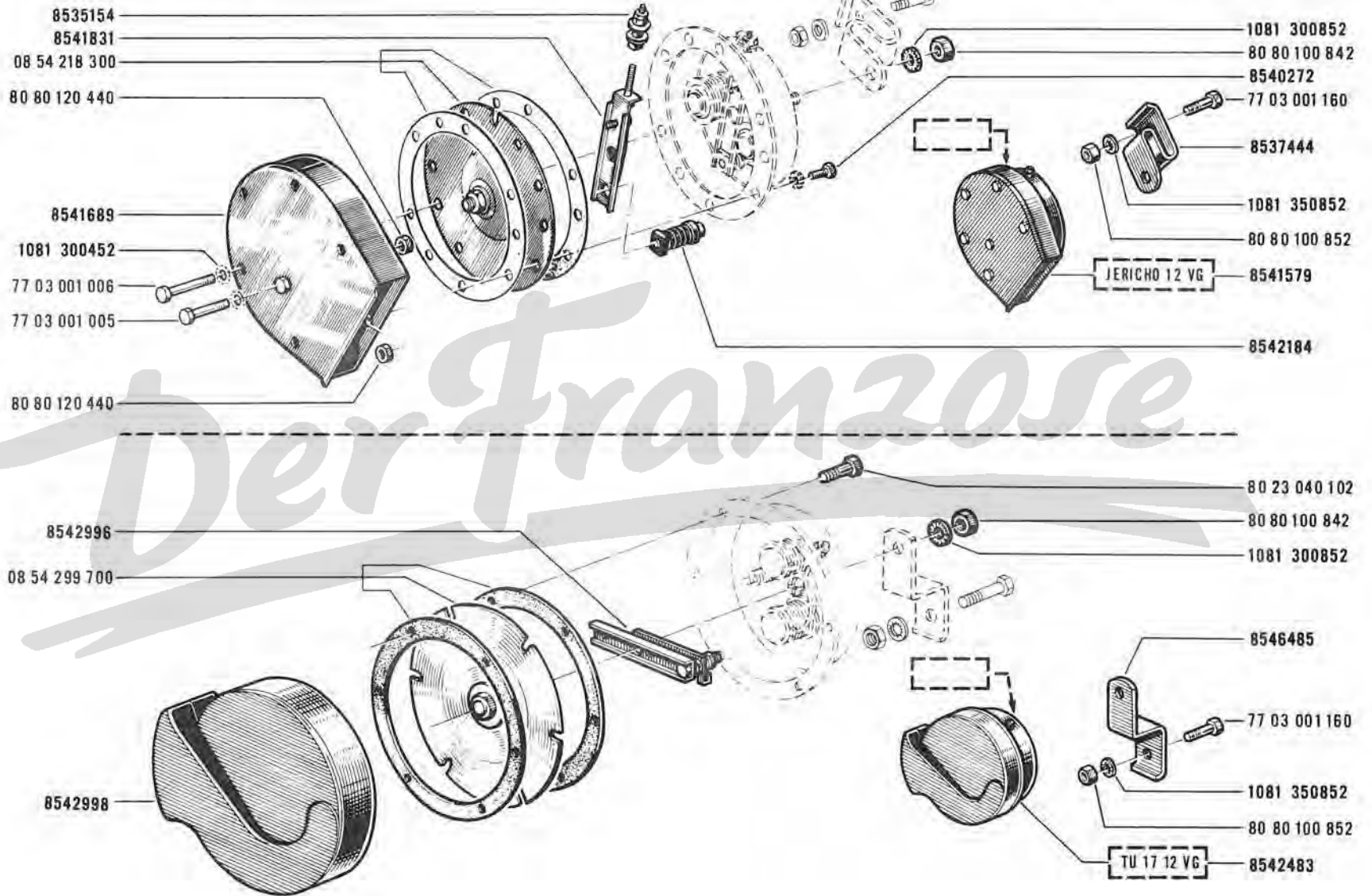

Der Franzose



60.61
B P.R. 810

[R.2134] VEH n° 1 ⇨ VEH n° 6364
[R.2135]

R.2134 / 10/20
R.2135 / 10/20 60-58

60.61
B P.R. 810

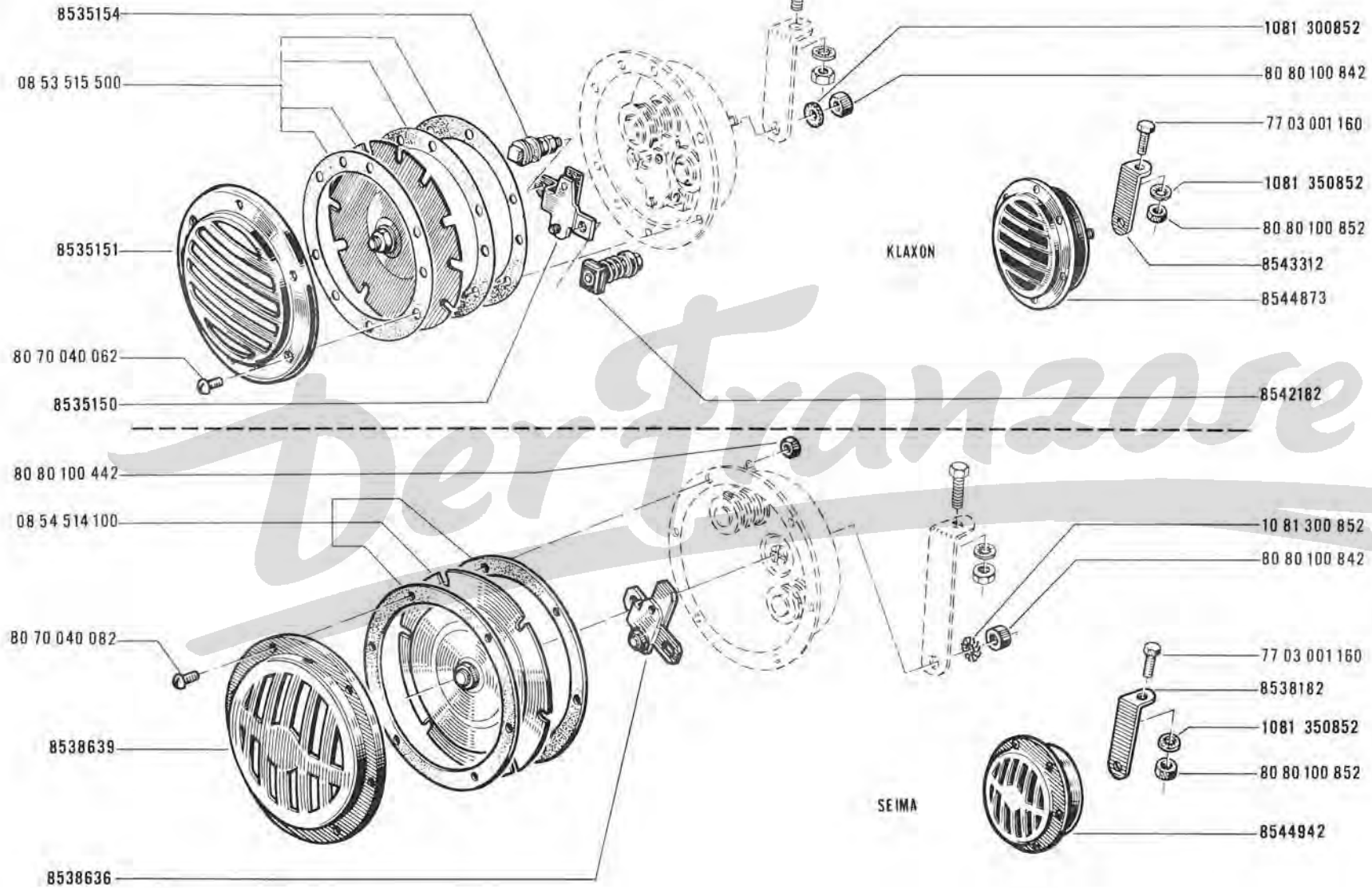

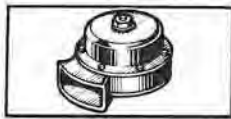

60.65

A P.R. 810



{ R.2134
R.2135 }

VEH n° 6365 ⇨ VEH n° ...

60.65

A P.R. 810

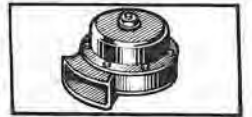

77 03 001 158

8080 100842

1081 300852

8556923

08 70 419 200

JERICO 8 12VG

1081 350852

8080 100852

8080 100842

1081 300852

08 70 596 600

TR 119 12VG

8080 100842

1081 300852

77 03 001 158

8556924

1081 350852

8080 100852

08 70 419 400

TR 15 PL 12VG

77 03 001 158

8556923

1081 350852

8080 100852

Der Franzose



61 .01

B P.R. 810

R 2134 / 10/11/12/13/14/15/18/20/21/24/26/27/28/29/30/40
42/81/84/89/100/101/102/103/120/121/122/130/140
R 2135 / 200/201/202/203/207/211/220/230/231/241/242/801/807/811

61 .01

B P.R. 810



R 2134 / 13/102 8548802 }
R 2135 / 8548801 }

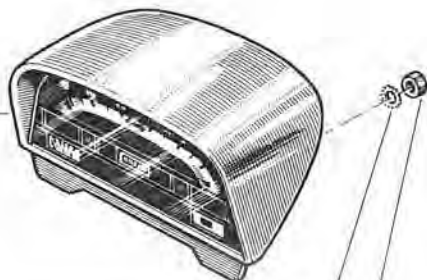

1081 340652

80 80 100 652

8549562

8542620

8543604

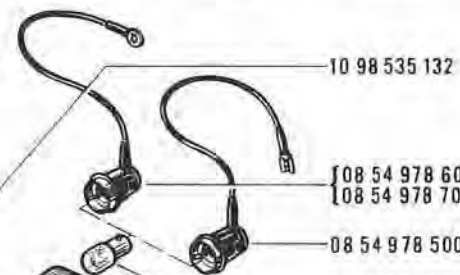
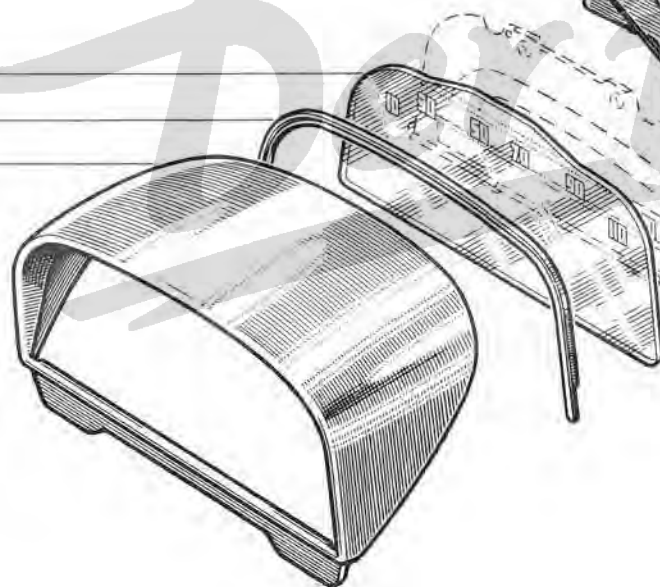

10 98 535 132

{ 08 54 978 600 (A=300)
08 54 978 700 (A=500)

08 54 978 500 (A=300)

8551322 (2W)

8543601

8548088 (4W)

8549053

8542619

8545378





61.04

B P.R. 810

R.2134 / 22/41/70/80/86/88/204/240/700/800/803/810
R.2135

61.04

B P.R. 810



8551049

1081 340652

80 80 100 652

8549563

8542620

8543604

[08 54 978 600 (A=300)]
[08 54 978 700 (A=500)]

10 98 535 132

08 54 978 500 (A=300)

8551322 (2W.)

8543601

8548088 (4W.)

8549053

8542619

8545374





61.10

B P.R. 810

61.10

B P.R. 810

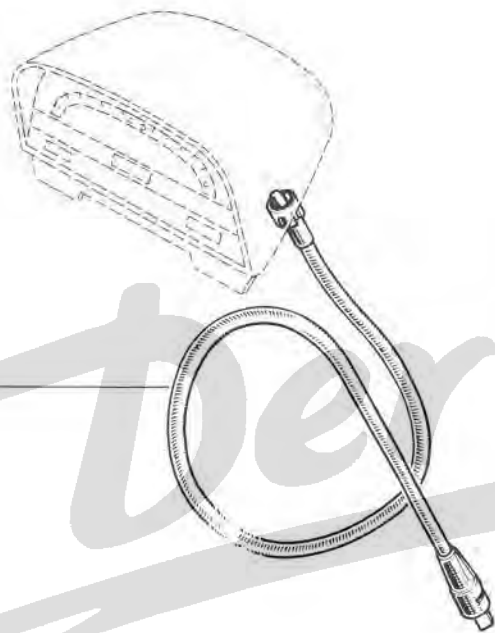
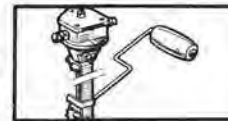

08 54 318 800
08 54 318 900

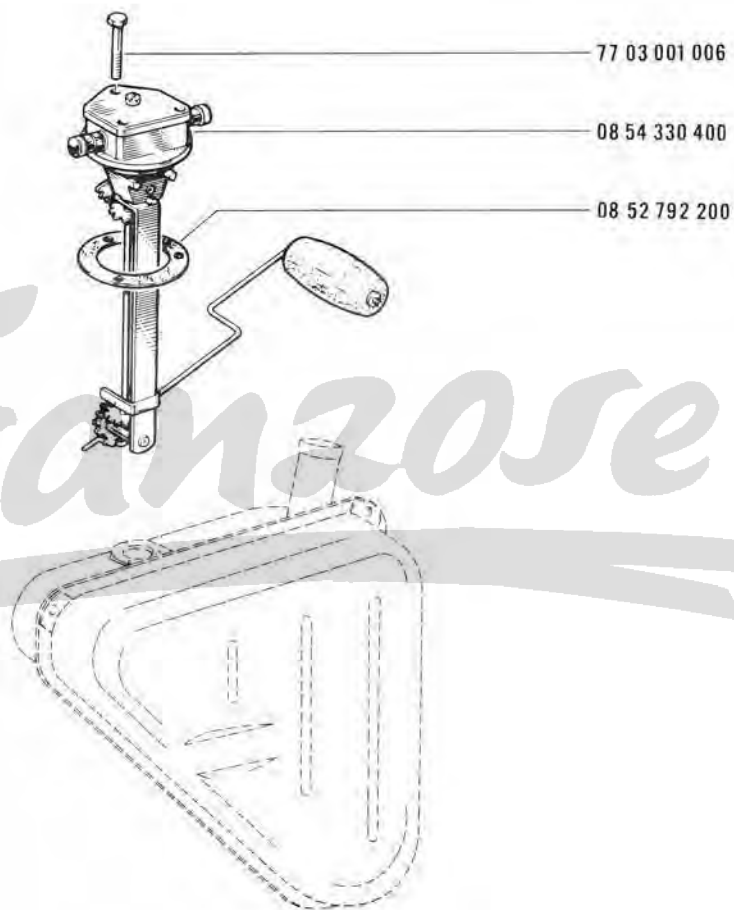

Der Franzose

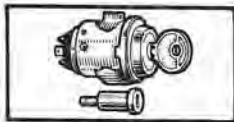

61.16

B P.R. 810

 [R.2134 / R.2135] VEH n° 1 □ VEH n° 6364

61.16

B P.R. 810

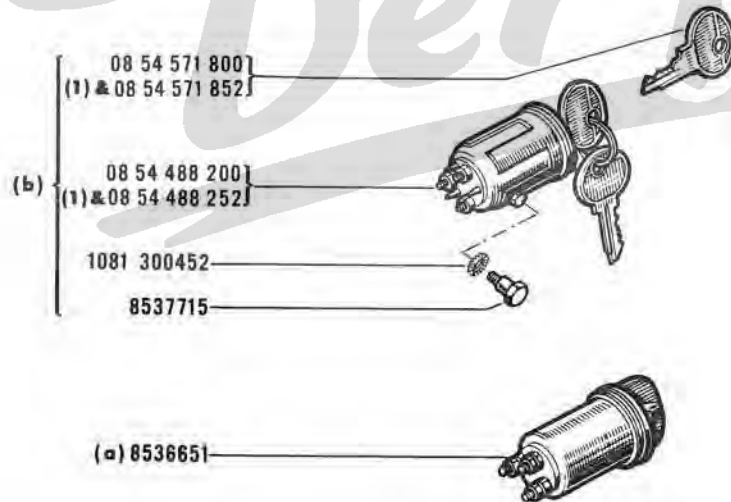
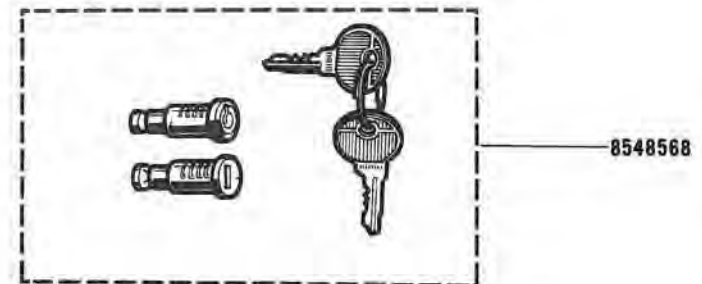
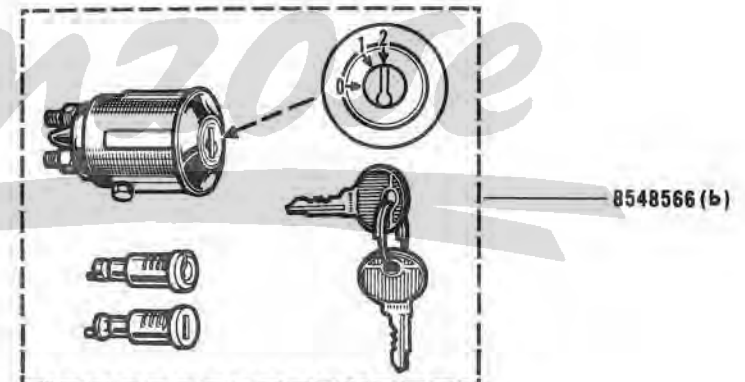
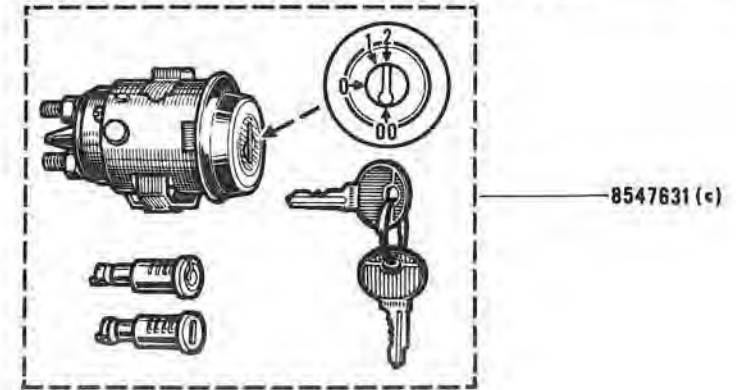
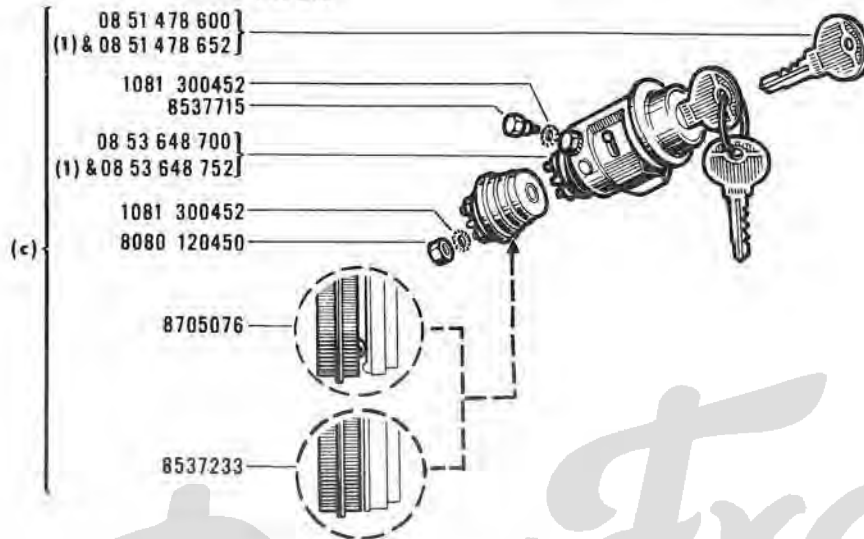
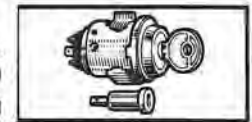

(a)	R 2134, R 2135	/10/11/13/18/27/29
(b)	R 2134, R 2135	/41/70
(c)	R 2134, R 2135	/12/14/15/20/21/22/24/26/28/30/40/42/80/81/84/86/88/89
	R 2134, R 2135	□ /10/11/13/18/27/29



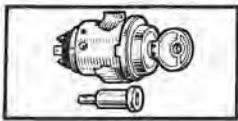

61.17.1

A P.R. 810

{R.2134
R.2135} VEH n° 6365 ⇨ VEH n°

R.2134

61.17.1

A P.R. 810

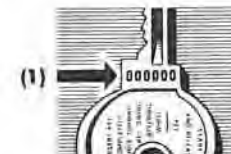
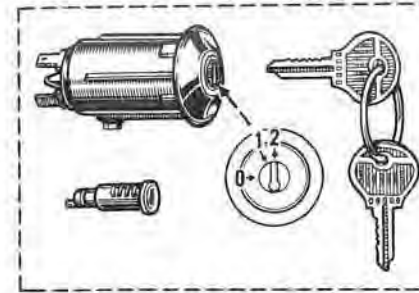
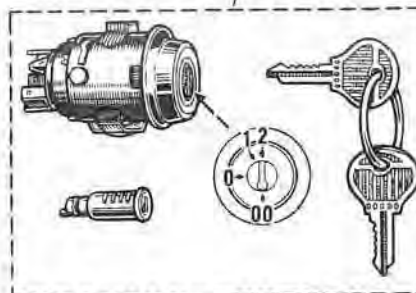
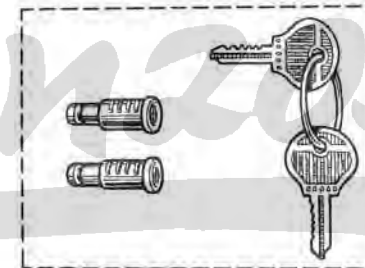
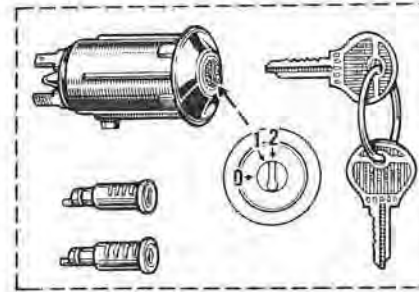
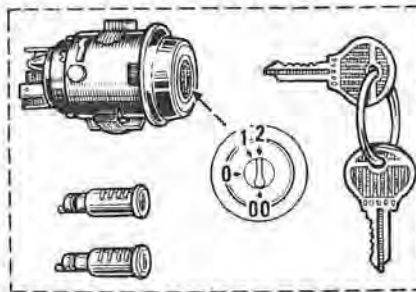
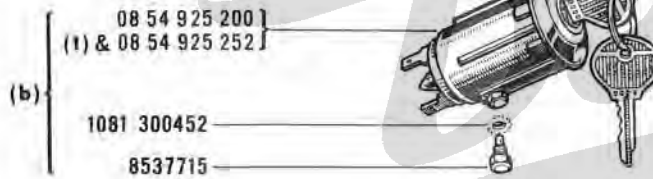
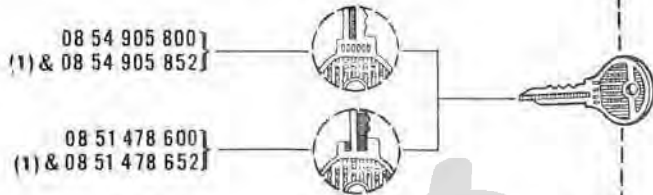
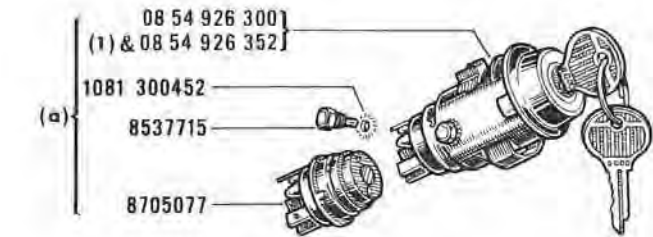
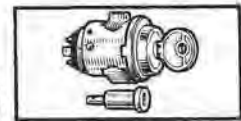

8558353 (b)

8558350 (a)

8548568

8558351 (c)

8558352 (d)



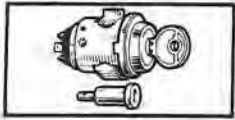

61.17.2

A P.R. 810

61.17.2

A P.R. 810

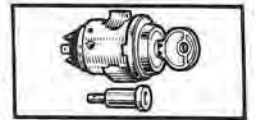

	R.2134	/	12/14/15/20/21/22/24/26/28/30/40	} VEH n° 6365 ◻ VEH n° . . .
	R.2135	/	42/80/81/84/86/88/89	
(a)	R.2134	/	120/121/122/140/200/201/202/203/204/207	
	R.2135	/	211/220/241/242/800/801/803/807/810/811	
	R.2134	/	10/11/13/18/27/29 VEH n° 6365 ◻ VEH n° . . .	
	R.2135	/	100/101/102/103/130/230/231	
(b)	R.2134	/	41/70 VEH n° 6365 ◻ VEH n° . . .	
	R.2135	/	240/700	
(c)	R.2134	/	120/121/122/140/200/201/203/204/207/211	
	R.2135	/	220/241/242/800/801/803/807/810/811	
(d)	R.2134	/	240/700	
	R.2134	/	10/11/13/18/27/29 VEH n° 6365 VEH n° . . .	
(e)	R.2135	/	100/101/102/103/130/230/231	

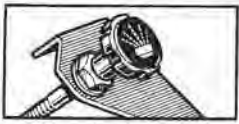

61 .18

B P.R. 810

R.2134 / 26/203
R.2135

61 .18

B P.R. 810



05 55 698 500



08 55 261 700

80 23 040 102

06 07 239 200

10 81 300 452

80 80 100 452

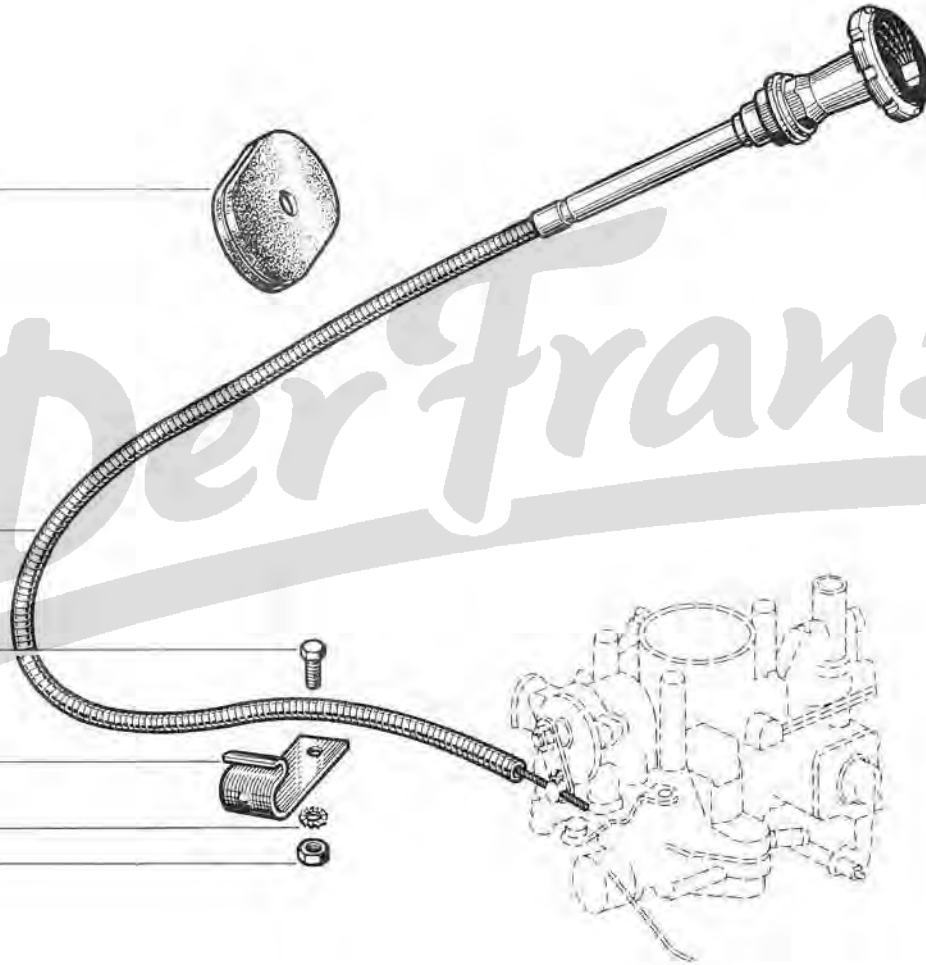



61.20

B P.R. 810

61.20

B P.R. 810

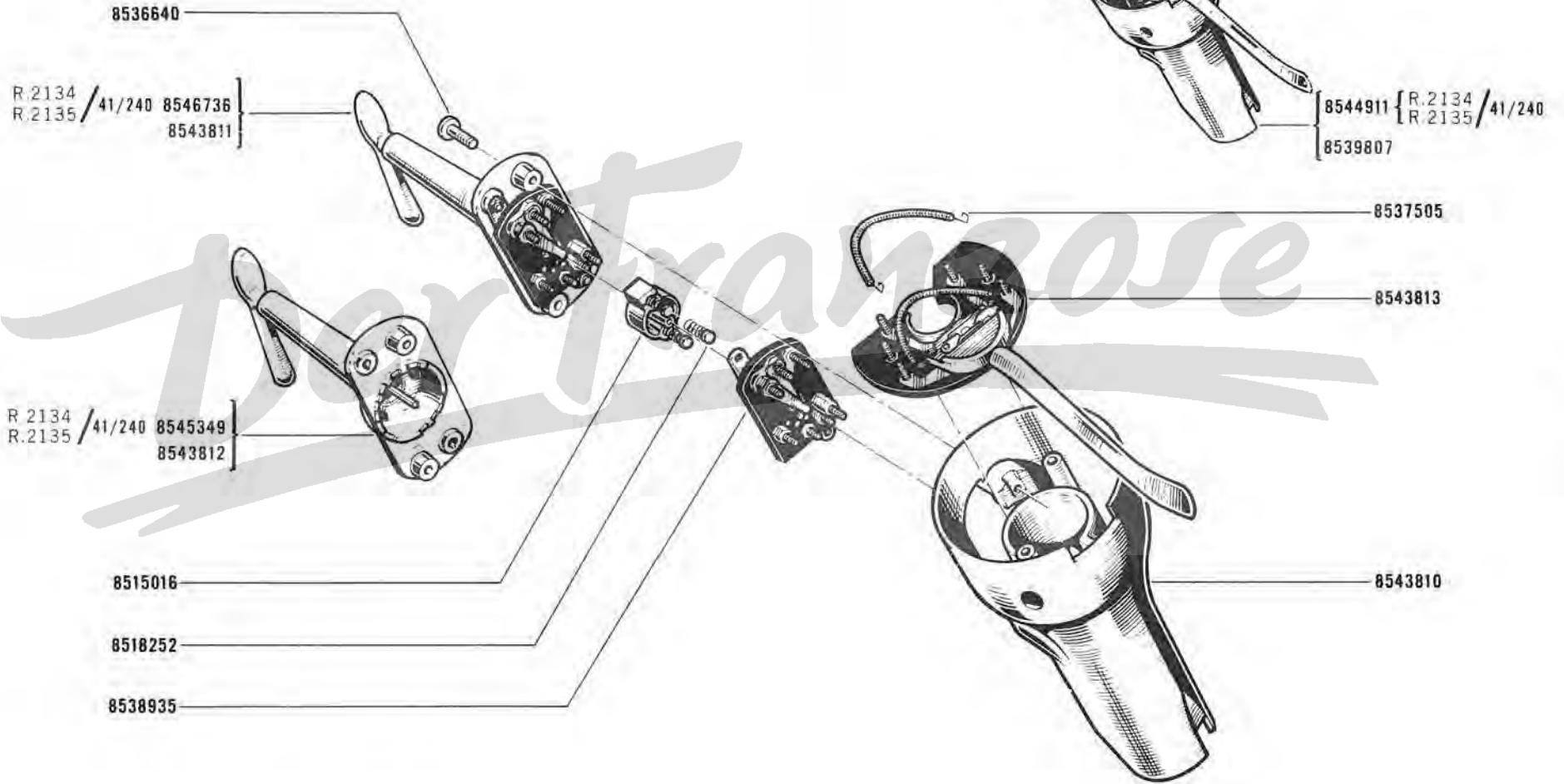

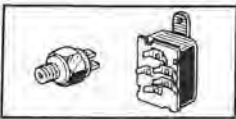

61.28

B P.R. 810

61.28

B P.R. 810

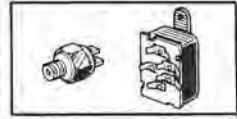

77 03 001 120

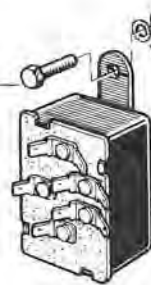

8080 100 652

1081 300652

08 54 625 800

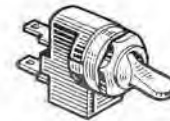
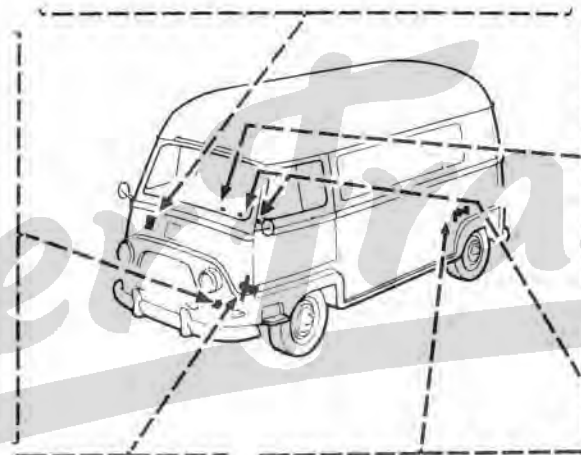

0854 058 900 (a)



0855 927 000 (b)

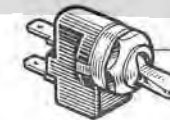

0854 058 900

07 06 178 300

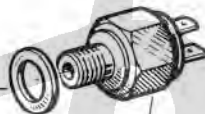

R. 2134 /12/120 08 55 758 800
R. 2135

08 54 250 300

08 54 482 100

R. 2134 /41/240
R. 2135

08 53 790 700

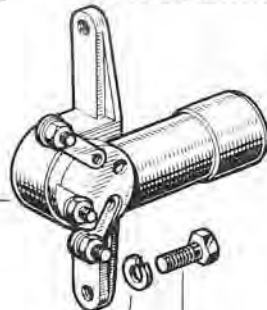

10 81 200 662

77 03 001 120

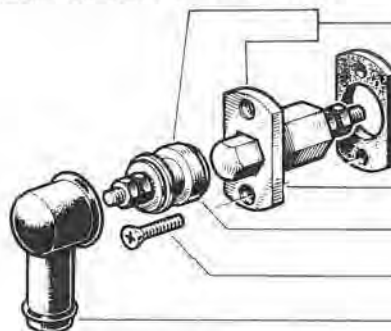

08 54 330 500

06 07 577 400

08 54 357 400

08 54 357 300

80 63 040 102

08 54 599 700

(a) R 2134, R 2135 { /120
/120 VEH n° 1 ⇨ VEH n° 12441

(b) R 2134, R 2135 /120 VEH n° 12442 ⇨ VEH n°...



61.30

B P.R.810



(R.2134 / 41/240 (R.2135 / 41/240 (eye icon) 61-32)

61.30

B P.R.810

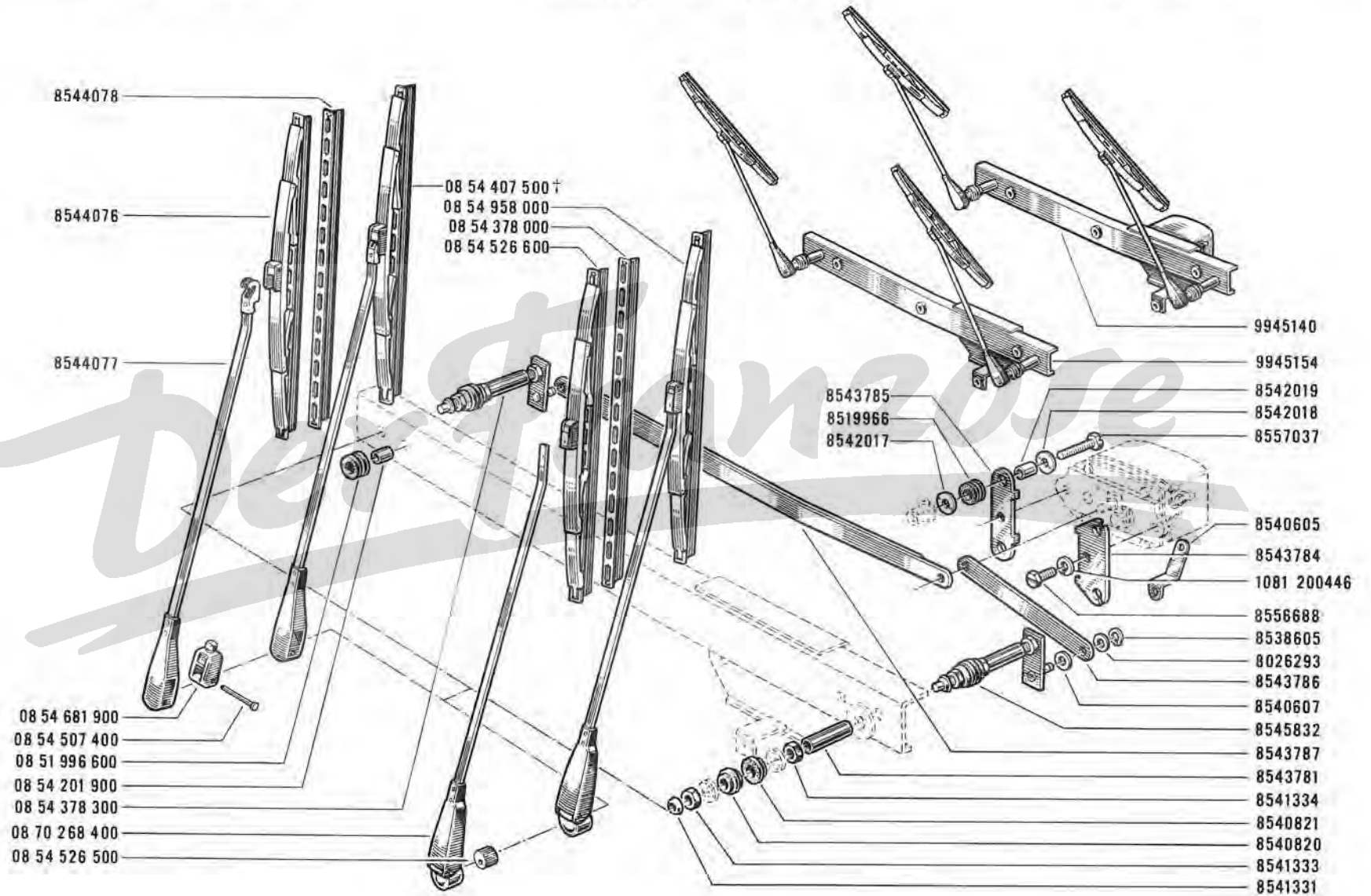
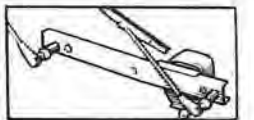



61.32

B P.R.810

R.2134 / 41/240
R.2135

61.32

B P.R.810

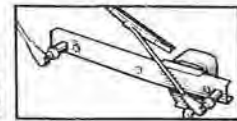

- 08 54 378 700
- 08 54 378 000
- 08 54 526 600
- 08 54 378 300
- 08 54 201 900
- 08 51 996 600

09 94 514 200

09 94 513 900

- (55) { 77 01 001 149
- 77 01 001 150
- 77 01 005 248

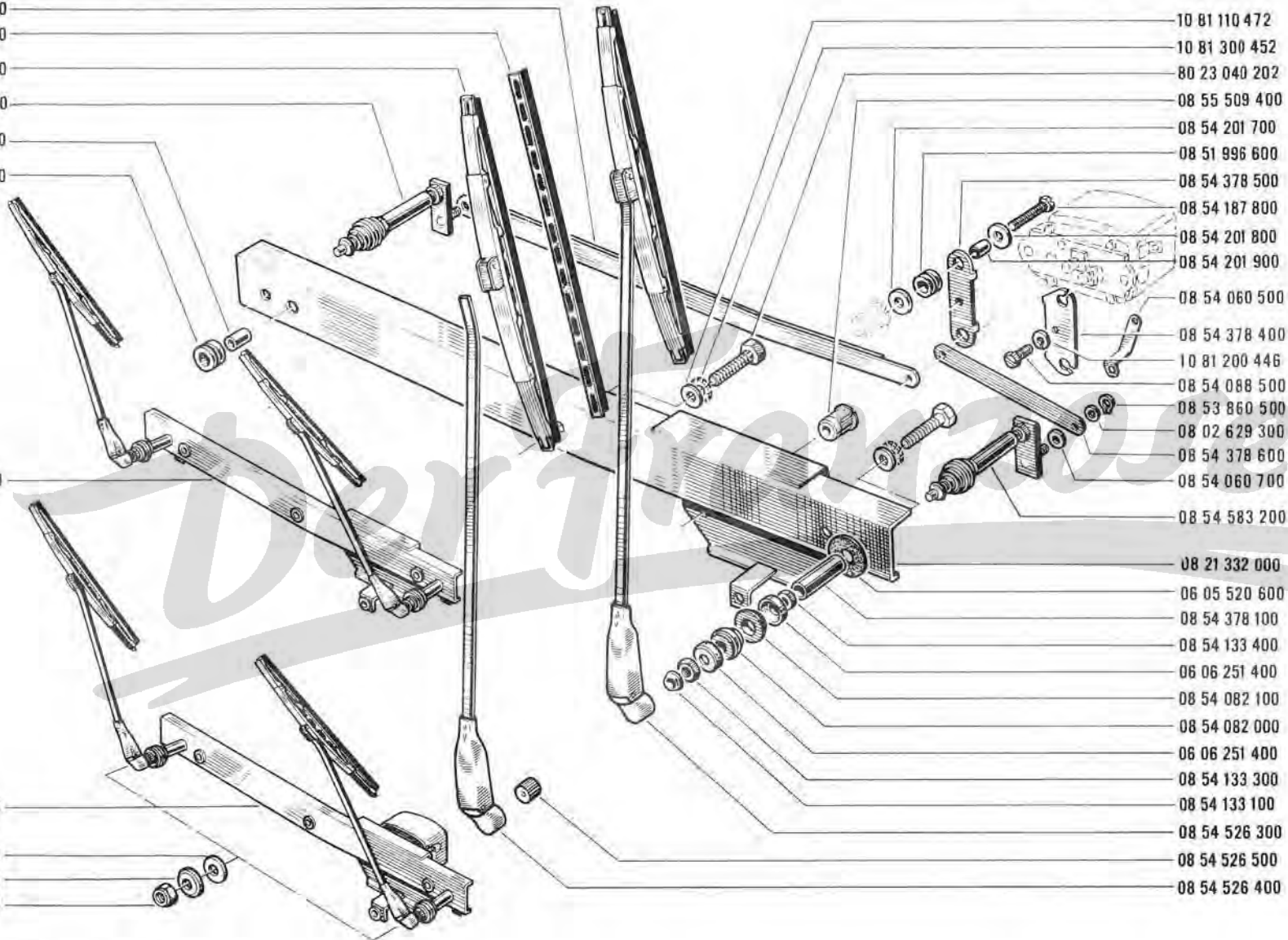

- 10 81 110 472
- 10 81 300 452
- 80 23 040 202
- 08 55 509 400
- 08 54 201 700
- 08 51 996 600
- 08 54 378 500
- 08 54 187 800
- 08 54 201 800
- 08 54 201 900
- 08 54 060 500
- 08 54 378 400
- 10 81 200 446
- 08 54 088 500
- 08 53 860 500
- 08 02 629 300
- 08 54 378 600
- 08 54 060 700
- 08 54 583 200
- 08 21 332 000
- 06 05 520 600
- 08 54 378 100
- 08 54 133 400
- 06 06 251 400
- 08 54 082 100
- 08 54 082 000
- 06 06 251 400
- 08 54 133 300
- 08 54 133 100
- 08 54 526 300
- 08 54 526 500
- 08 54 526 400

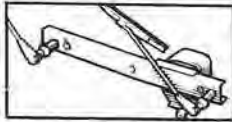

61.34

B P.R. 810



61.34

B P.R. 810

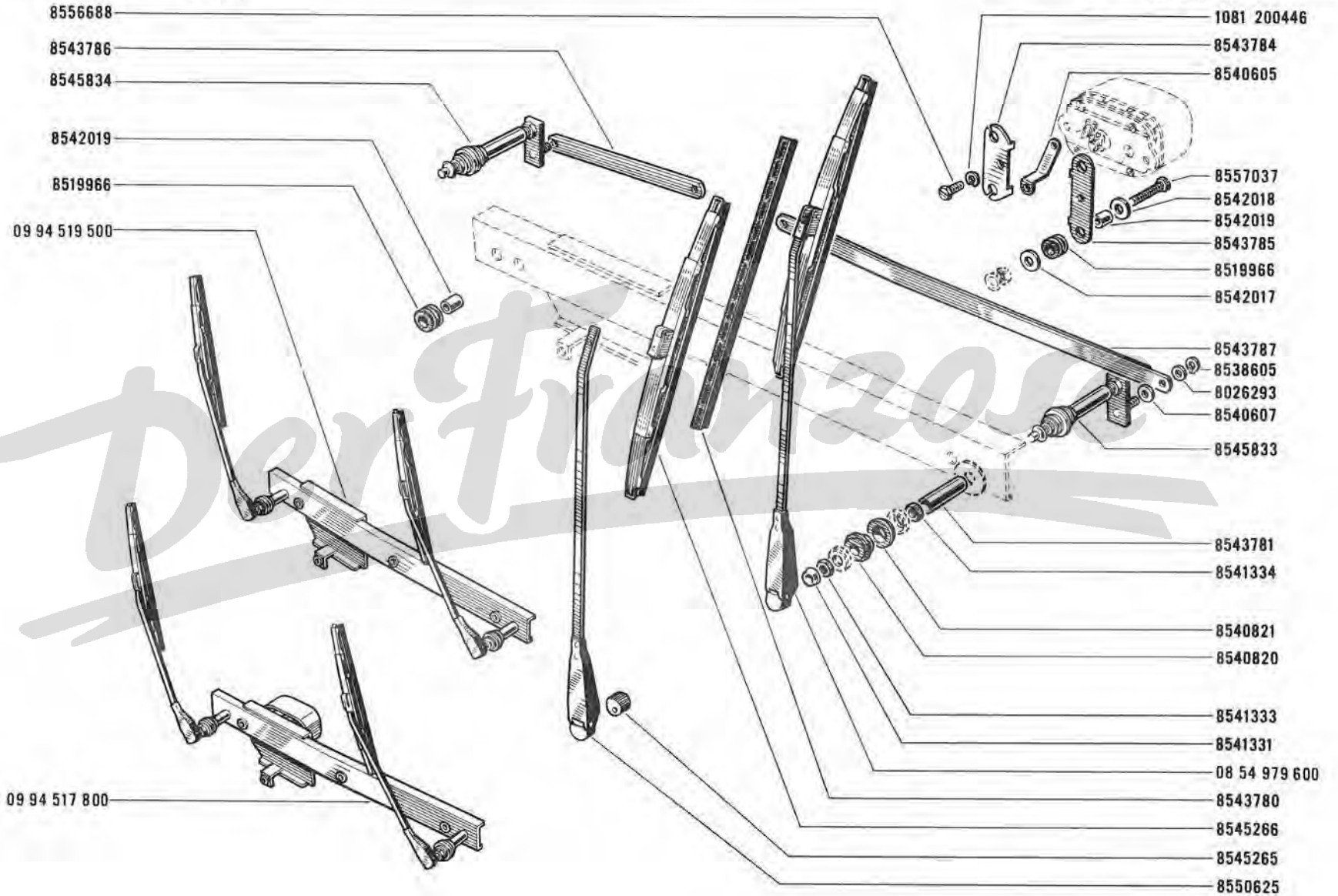

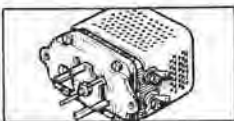

61.36

B P.R. 810

61.36

B P.R. 810

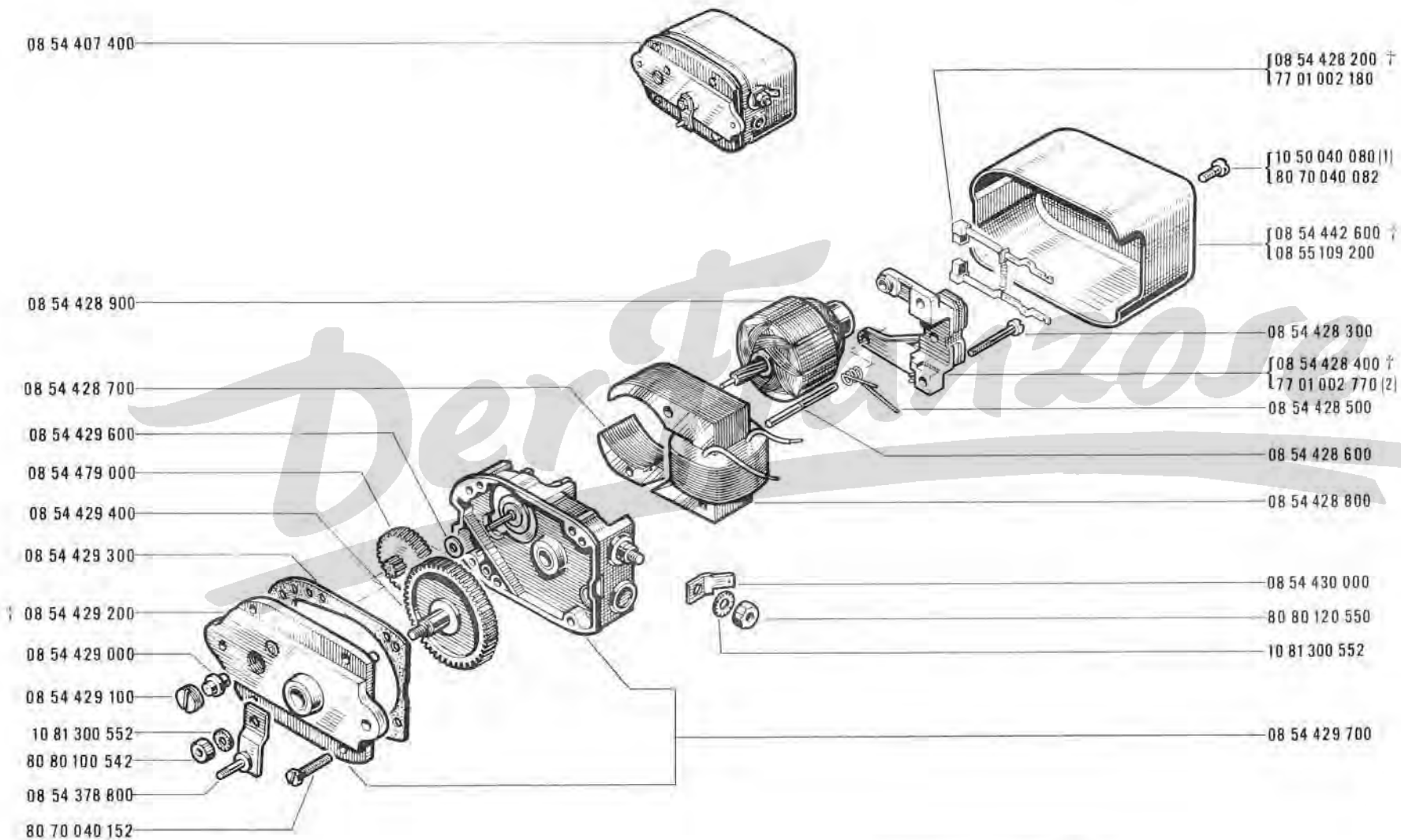
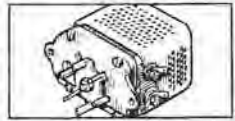

(1) 08 54 428 400

(2) 80 70 040 082 -1-

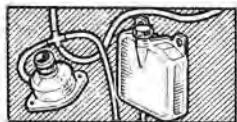

61.38

A P.R. 810

R 2134 / 40/42/241/242
R 2135 / 101 VEH n° 16366 ⇨ VEH n°...

61.38

A P.R. 810

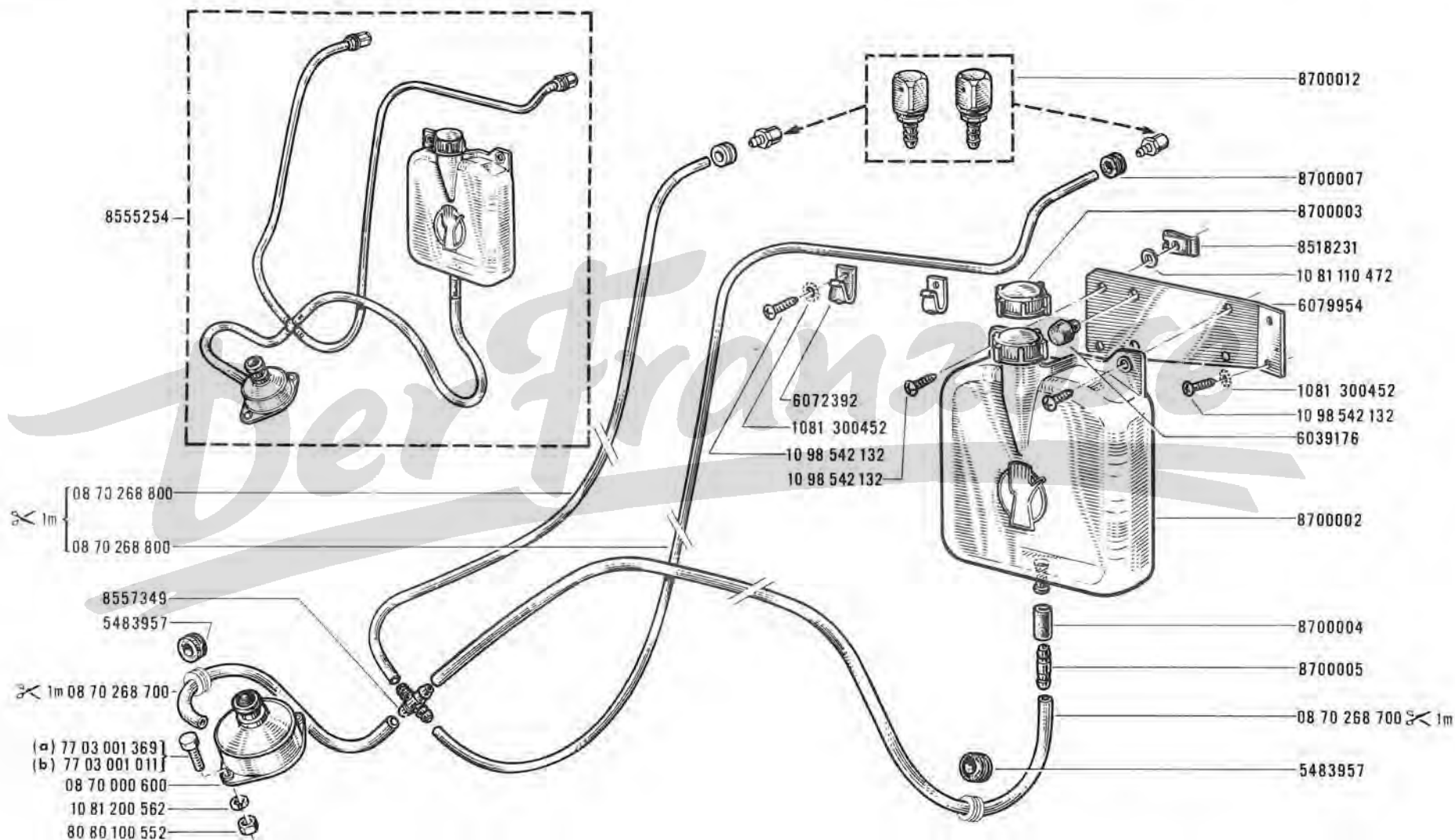

(a)	R 2134 / 40/42	VEH n°	1 ⇨ VEH n° 16365
	R 2135 / 241/242		

(b)	R 2134 / 40/42	VEH n° 16366 ⇨ VEH n°...
	R 2135 / 101/241/242	

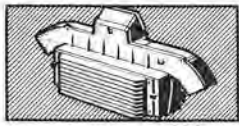

61.42

B P.R.810

61.42

B P.R.810

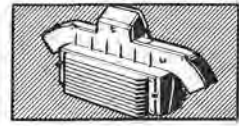

08 54 868 800

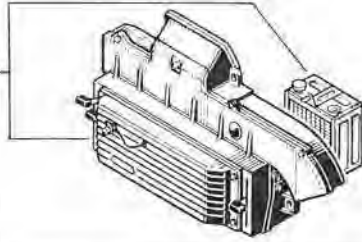

10 81 300 552
80 80 100 542
08 55 091 300
08 55 091 400
08 54 455 000

80 80 100 542
10 81 300 552
80 23 050 252
08 55 091 500
08 55 090 800
80 80 100 542
10 81 110 552
08 55 092 200
08 55 092 100
08 54 232 300
08 54 960 300

08 55 092 000
10 81 110 552
77 03 001 013
77 03 001 369
77 03 001 369
08 55 092 300

80 80 100 542
10 81 110 552
08 54 430 000

10 81 110 452
77 03 001 005
77 03 001 006
08 52 681 900

08 54 232 300
08 54 960 400
08 55 091 700
08 55 091 100
08 55 090 900

08 54 455 000
80 23 040 162
80 80 100 442
10 81 110 552
08 55 090 400 $\varnothing < 1m$
08 55 090 500
08 55 090 400 $\varnothing < 1m$
08 55 090 200
08 55 090 400 $\varnothing < 1m$

08 54 321 500

06 04 852 400

08 54 448 400

05 55 254 100

08 55 090 600

10 81 110 672

10 81 300 652

80 80 100 652

08 55 090 700

10 81 110 572

10 70 050 302

80 23 050 252

10 81 110 552

08 55 091 900

80 83 100 552

08 55 091 600

80 80 100 442

10 81 110 452

08 55 091 800

08 55 091 200

08 55 091 000

10 81 110 652

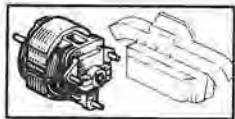

61.45

B P.R. 810



61.45

B P.R. 810

80 70 040 082

08 55 094 200

08 54 453 100

08 54 960 200

10 81 310 452

08 55 094 900

08 55 680 800

08 55 093 900

08 55 094 000

80 70 040 152

08 55 094 100

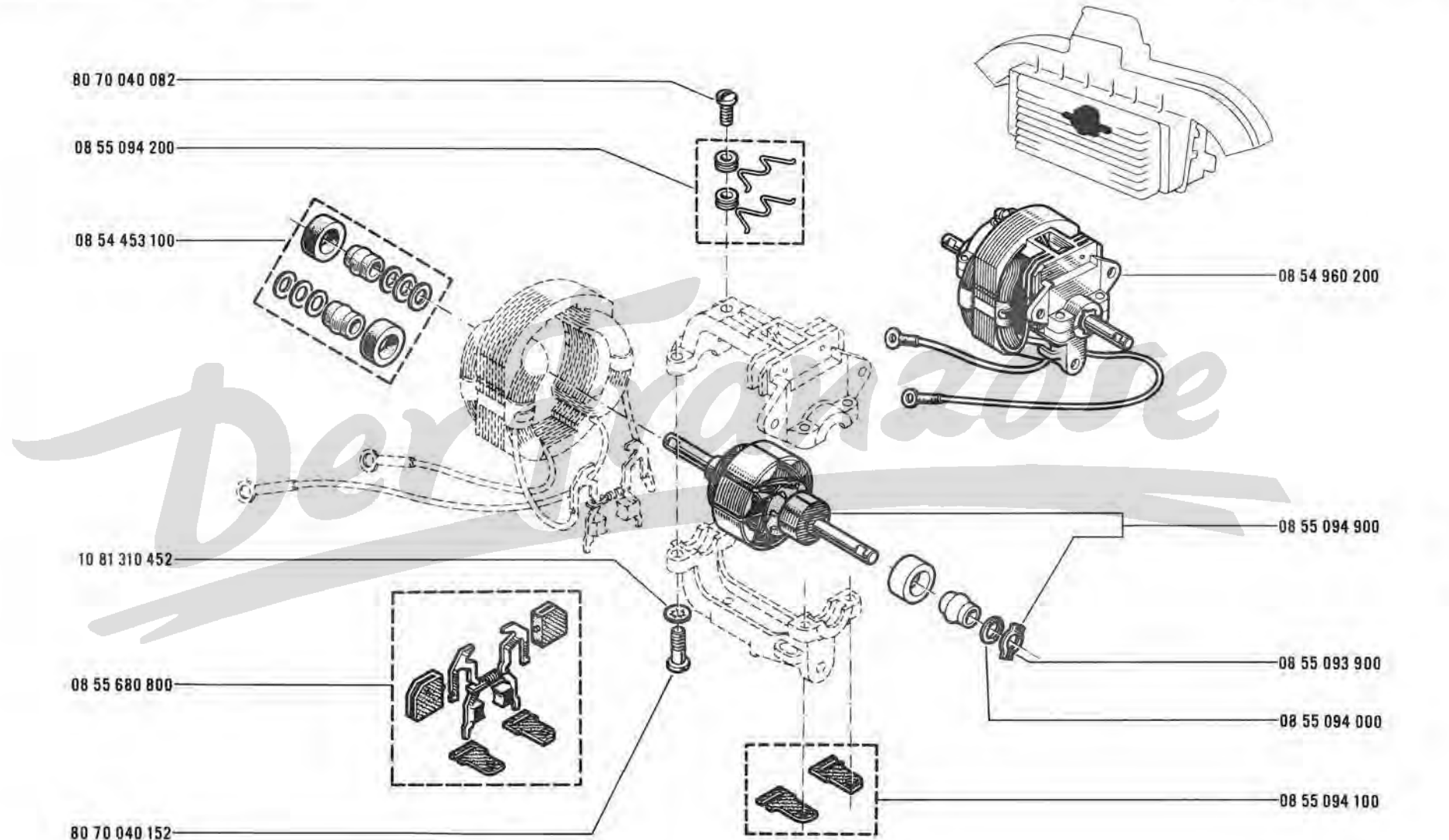

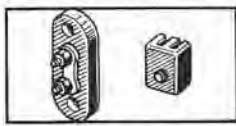

62.30

B P.R. 810

62.30

B P.R. 810

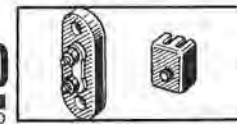

(d) 08 54 855 800
(e) 08 55 534 900

(d) 08 54 939 200
(e) 08 70 002 300

10 98 535 162

07 05 905 400

10 81 110 452

80 72 040 152

08 53 664 900

08 53 516 900

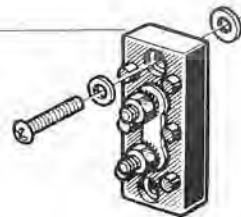
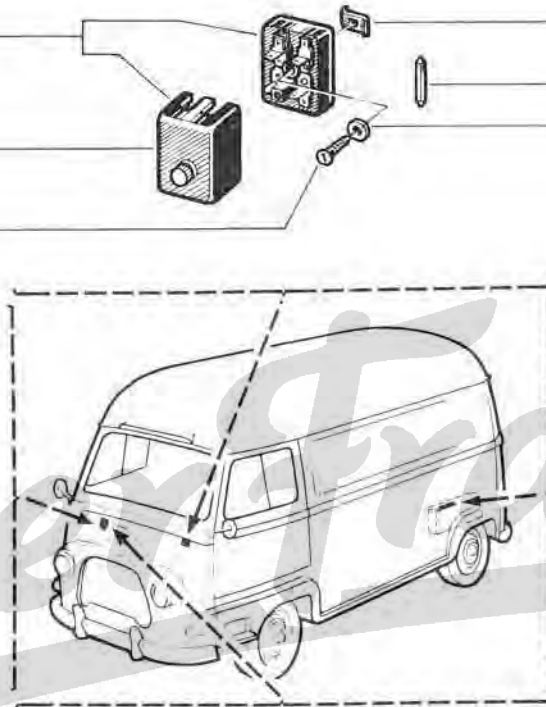

08 54 489 100

[08 54 865 800 †(25A)
[08 55 824 000 (15A)

10 81 110 452

80 72 040 152

10 81 300 452

08 55 066 600 (b)

[08 54 145 500 (a)
[08 54 531 300 (c)

08 33 083 000

10 81 110 452

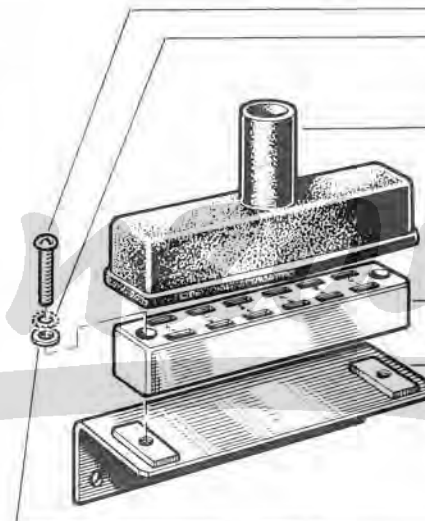

(a)	R 2134	10/11/12/14/18/20/21/22/24/26/27/28/29/30/40/41/42/100/101/103/120
	R 2135	121/130/140/200/201/202/203/204/207/211/220/230/231/240/241/242
		15 VEH n° 1 ⇨ VEH n° 6364

(b)	R 2134	20/21/22/24/26/27/28/29/30/40/41/42/80/81/84/86/88/89/140/200/201/202
	R 2135	203/204/207/211/220/230/231/240/241/242/800/801/803/807/810/811

(c)	R 2134	13/70/80/81/84/86/88/89/102/700/800/801/803/807/810/811
	R 2135	15 VEH n° 6365 ⇨ VEH n° ...
		122

(d) VEH n° 1 ⇨ VEH n° 6364

(e) VEH n° 6365 ⇨ VEH n° ...



62.40
B P.R. 810

62.40
B P.R. 810



{ 08 55 791 100 }
{ 77 00 514 895 }

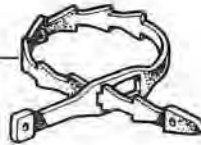

8546945

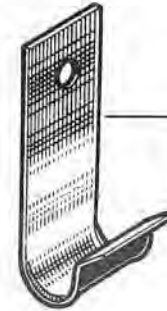

6073215

{ A=6,5 | 06 02 989 600 }
{ A=4,5 | 06 03 871 100 }



8544237



7062042

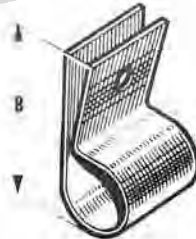

6072392

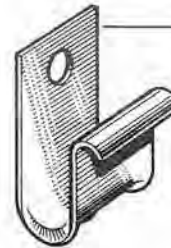

8543572



{ B=40 | 06 03 518 300 }
{ B=52 | 06 03 400 600 }

Der Franzose

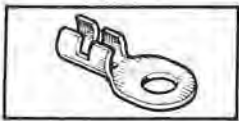

62.43

B P.R. 810

62.43

B P.R. 810



8539912

8539904

08 54 769 200

08 54 769 300

(A=3 ⇨ 4) 08 53 990 700

8539905

(A=2 ⇨ 3) 8539908

(A=3 ⇨ 4) 8539909

(A=4 ⇨ 5) 8539910

8539906

8539911

(A=3, 9) { 08 54 951 400

08 55 651 900

(A=5, 4) { 08 54 951 500

08 55 652 000

8549516

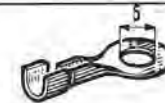
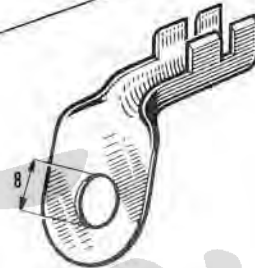
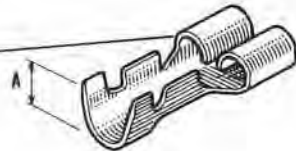
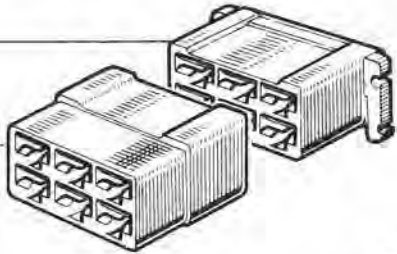

8558447

8544112

8558439

6036908

6070750

6045060

{ 5554378 (B=4) (A=4, 2)

{ 5555061 (B=4) (A=5, 2)

6070749

{ 5555069 (A=5, 2)

{ 5555070 (A=6, 2)

{ 6063038 (A=3, 5)

{ 6063039 (A=5, 5)

6080449

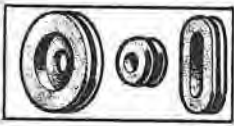

62.46

B P.R. 810

62.46

B P.R. 810

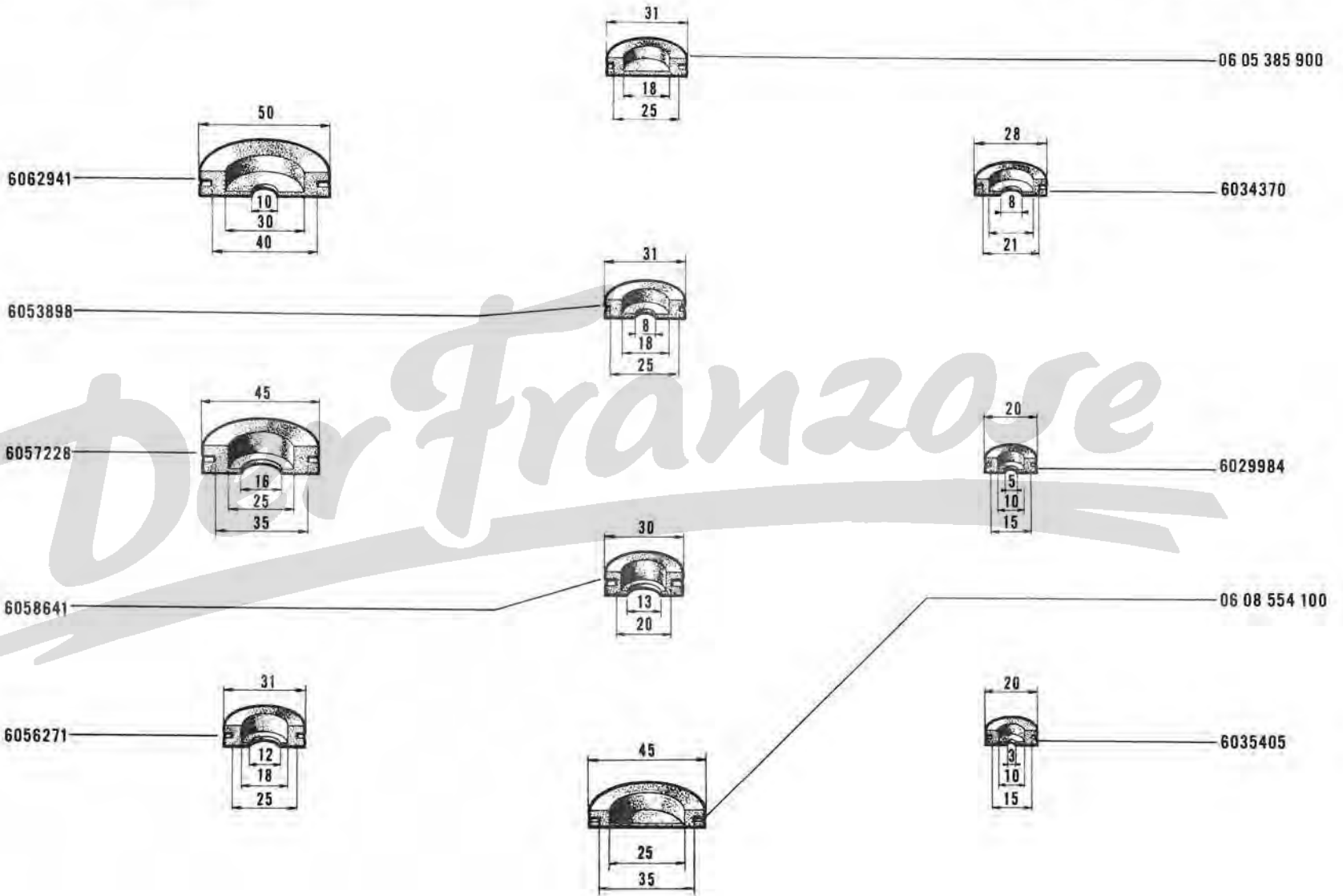
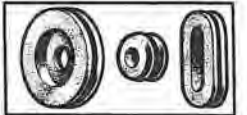

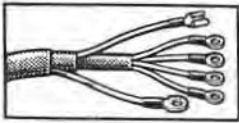

62.50.1

B P.R. 810

 (h)

62.50.1

B P.R. 810

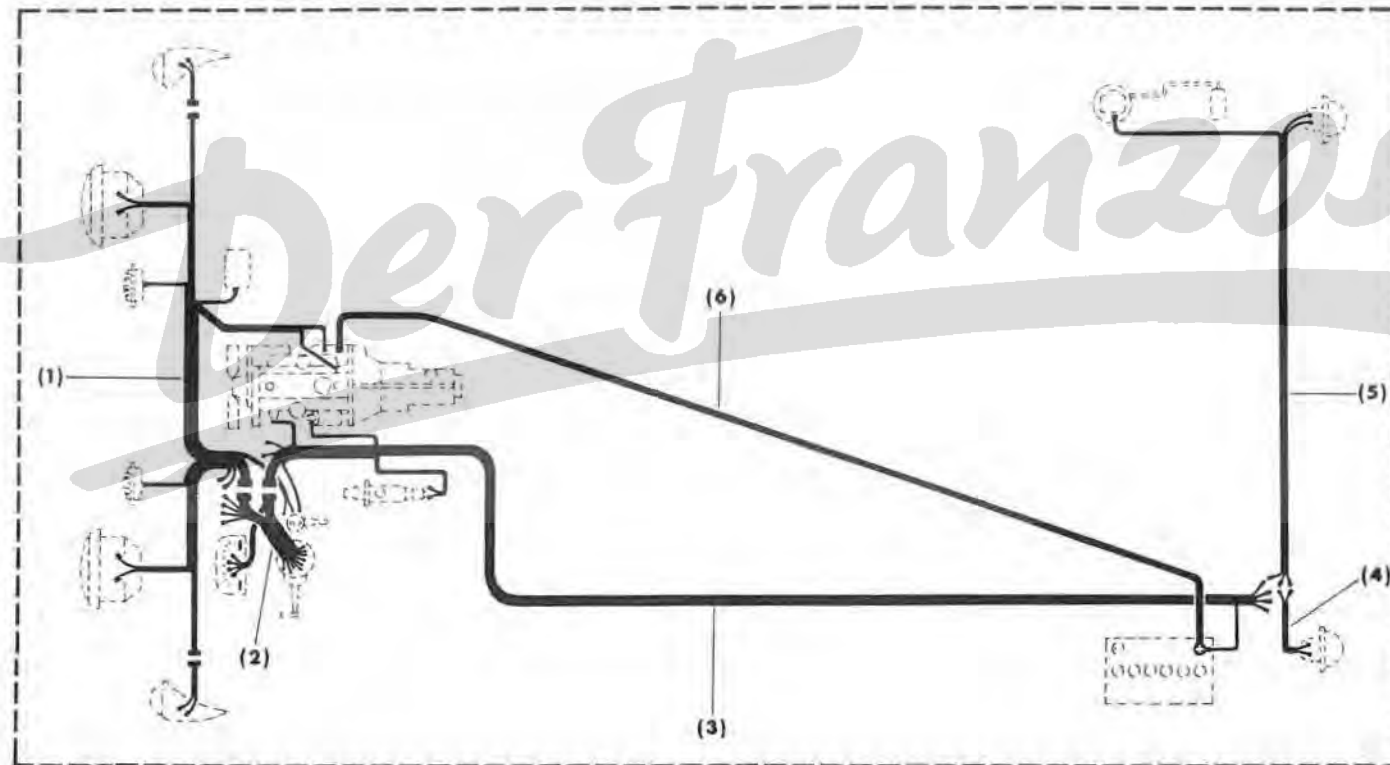
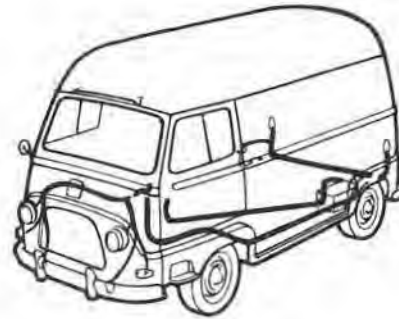
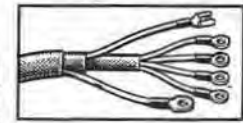

- | | | | |
|-------------|-------------|---|-------------|
| } | (d) 9837344 | } | 9837349 (g) |
| | (b) 9837345 | | 9837350 (a) |
| | (e) 9837346 | | |
| (c) 9837347 | | | |
| (f) 9837348 | | | |

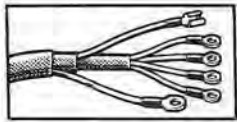
**62.50.2**

B P.R. 810

62.50.2

B P.R. 810

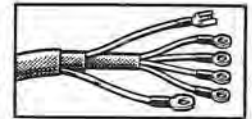

	9837344	9837345	9837346	9837347	9837348	9837349	9837350
(1)	9504972	9504979	9504982	9504972	9505139	9504988	9504998
(2)	9504501	9504501	9504981	9504501	9505138	9504987	9504987
(3)	9505454	9505454	9505457	9505454	9505454	9505458	9505458
(4)	9504221	9504221	9504543	9504221	9504221	9504543	9504543
(5)	9504222	9504222	9504544	9504222	9504222	9504544	9504544
(6)	9505456	9505456	9505456	9505456	9505456	9505456	9505456

	R.2134	/	89
(a)	R.2135	/	80/81/84/86/88 VEH n° 1 ⇨ VEH n° 6364
	R.2134	/	12/14/18 VEH n° 1 ⇨ VEH n° 6364
(b)	R.2135	/	12/14/18 VEH n° 1 ⇨ VEH n° 6364
	R.2134	/	30/40/42 VEH n° 1 ⇨ VEH n° 6364
(c)	R.2135	/	30/40/42 VEH n° 1 ⇨ VEH n° 6364
	R.2134	/	15/29/122
(d)	R.2135	/	10/11/20/21/22/24/26/27/28 VEH n° 1 ⇨ VEH n° 6364
	R.2134	/	13 VEH n° 1 ⇨ VEH n° 6364
(e)	R.2135	/	13 VEH n° 1 ⇨ VEH n° 6364
	R.2134	/	41 VEH n° 1 ⇨ VEH n° 6364
(f)	R.2135	/	41 VEH n° 1 ⇨ VEH n° 6364
	R.2134	/	70 VEH n° 1 ⇨ VEH n° 6364
(g)	R.2135	/	70 VEH n° 1 ⇨ VEH n° 6364
	R.2134	/	10/11/12/13/14/18/20/21/22/24/26/27 VEH n° 1 ⇨ VEH n° 6364
(h)	R.2135	/	28/30/40/41/42/70/80/81/84/86/88 VEH n° 1 ⇨ VEH n° 6364
	R.2135	/	15/29/89/122

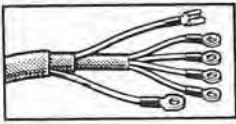

62.51.1

A P.R. 810

 (h)

62.51.1

A P.R. 810

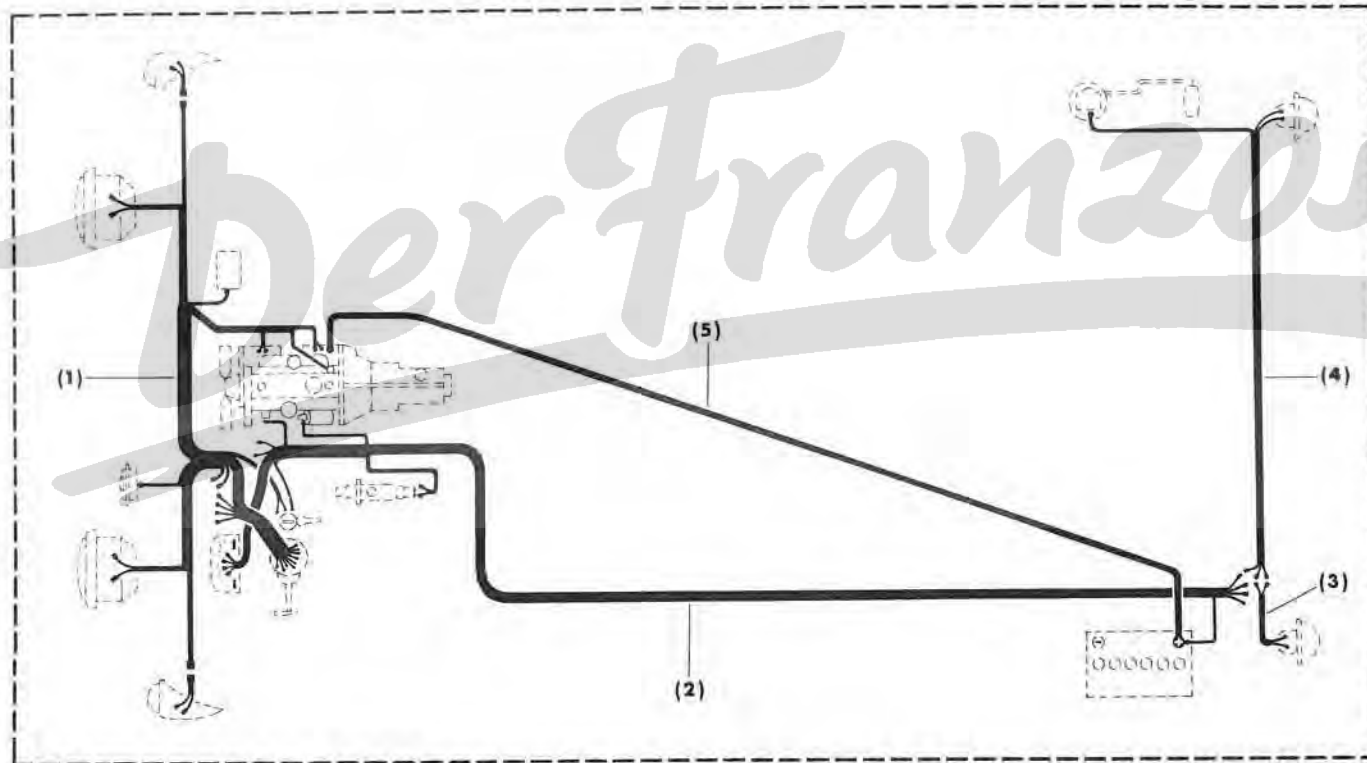
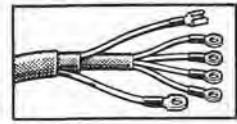

- | | | |
|-------------|-------------|---|
| (a) 9837619 | 9837625 (f) | } |
| (b) 9837620 | 9837626 (g) | |
| (c) 9837621 | | |
| (d) 9837622 | | |
| (e) 9837623 | | |

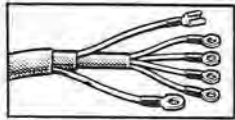

62.51.2

A P.R. 810

62.51.2

A P.R. 810

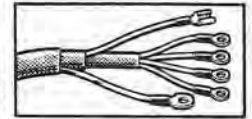

	9837619	9837620	9837621	9837622	9837623	9837625	9837626
(1)	9505757	9505762	9505765	9505770	9505772	9505790	9505796
(2)	9505761	9505761	9505769	9505761	9505761	9505780	9505780
(3)	9504221	9504221	9504543	9504221	9504221	9504543	9504543
(4)	9504222	9504222	9504544	9504222	9504222	9504544	9504544
(5)	9505456	9505456	9505456	9505456	9504257	9505456	9505456

De Franzose

(a)	R.2134	/	10/11/20/21/22/24/26/27/28	VEH n° 6365 ⇨ VEH n° . . .
	R.2135	/	100/101/103/200/201/202/203/204/207/211/220/230/231	
(b)	R.2134	/	12/14/18	VEH n° 6365 ⇨ VEH n° . . .
	R.2135	/	120/121/130	
(c)	R.2134	/	13	VEH n° 6365 ⇨ VEH n° . . .
	R.2135	/	102	
(d)	R.2134	/	30/40/42	VEH n° 6365 ⇨ VEH n° . . .
	R.2135	/	140/241/242	
(e)	R.2134	/	41	VEH n° 6365 ⇨ VEH n° . . .
	R.2135	/	240	
(f)	R.2134	/	70	VEH n° 6365 ⇨ VEH n° . . .
	R.2135	/	700	
(g)	R.2134	/	80/81/84/86/88	VEH n° 6365 ⇨ VEH n° . . .
	R.2135	/	800/801/803/807/810/811	
(h)	R.2134	/	10/11/12/13/14/18/20/21/22/24/26/27	VEH n° 6365 ⇨ VEH n° . . .
	R.2134	/	28/30/40/41/42/70/80/81/84/86/88	
	R.2135	/	100/101/102/103/120/121/130/140/200/201/202/203/204/207/211/220/230/231/240/241/242/700/800/801/803/807/810/811	

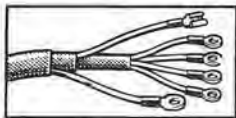

62.52.1



A P.R. 810

R.2134 

62.52.1

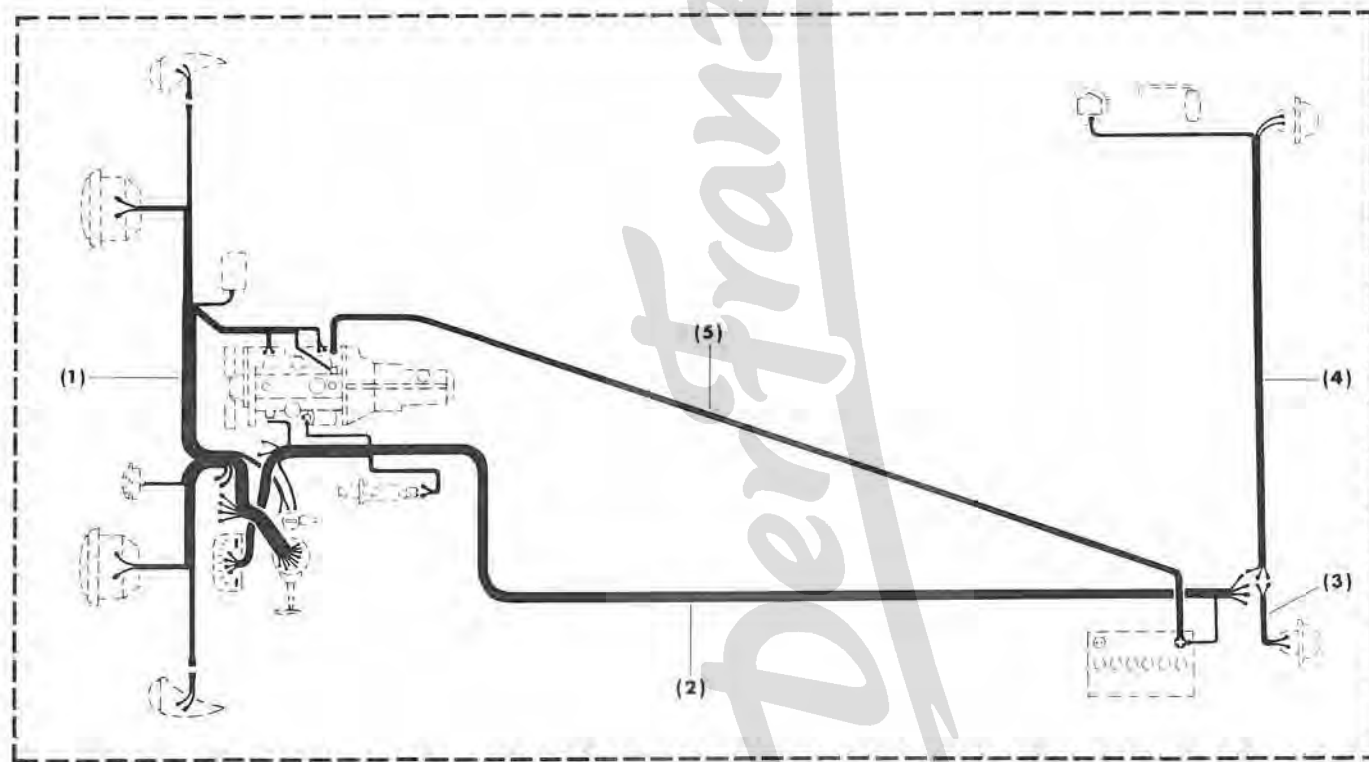
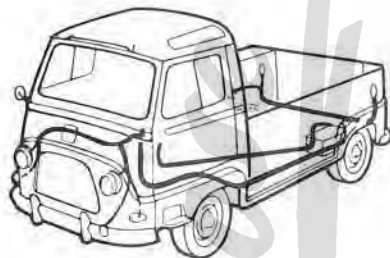
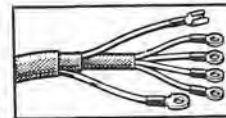
A P.R. 810



- | | | | |
|---|-------------|-------------|---|
|  | (a) 9837706 | 9837720 (g) |  |
| | (b) 9837708 | 9837722 (h) | |
| | (c) 9837710 | | |
| | (d) 9837712 | | |
| | (e) 9837714 | | |
| | (f) 9837716 | | |

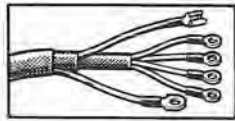

62.52.2

A P.R. 810

62.52.2

A P.R. 810

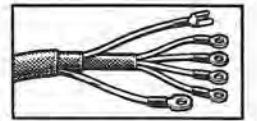

	9837706	9837708	9837710	9837712	9837714	9837716	9837720	9837722
(1)	9505757	9505762	9505765	9505770	9505772	9505774	9505790	9505796
(2)	9505761	9505761	9505761	9505761	9505761	9505769	9505780	9505780
(3)	9504221	9504221	9504543	9504221	9504221	9504543	9504543	9504543
(4)	9504222	9504222	9504544	9504222	9504222	9504544	9504544	9504544
(5)	9505456	9505456	9505456	9505456	9505456	9505456	9505456	9505456

Der Franzose

(a) R.2134/100/101/103/200/201/202/203/204/207/211/220/230/231

(b) R.2134/120/121/130

(c) R.2134/102

(d) R.2134/140/241/242

(e) R.2134/240

(f) R.2134/122

(g) R.2134/700

(h) R.2134/800/801/803/807/810/811

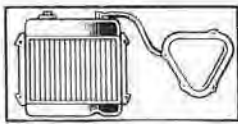

70.01

B P.R. 810

70.01

B P.R. 810

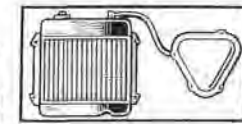

{08 55 720 500 †
08 52 632 000

77 03 001 116
08 53 064 700
10 81 200 662
08 53 064 800
08 53 066 700
08 53 066 400
08 55 079 400
08 54 831 100

06 06 732 602
06 06 732 700
04 28 209 000
10 81 200 662
80 80 100 652

08 53 065 200
80 80 100 852
10 81 300 862
07 05 961 100
08 54 693 400

† 08 54 609 500
† 08 55 959 900
08 55 538 600

☞ (A=760) 06 07 109 900
☞ (A=1155) 06 07 494 800

☞ 06 03 911 700
00 72 572 100
10 81 200 662
77 03 001 122
08 53 065 000
08 53 064 900
77 03 001 158
10 81 200 862
80 80 100 852

{08 55 720 400 †
08 52 631 900

08 52 830 500

08 52 896 600

{08 55 720 600 †
08 02 494 100

05 55 803 500

08 52 830 400

08 53 066 200

{08 55 720 500 †
08 52 632 000

80 80 100 552

10 81 300 552

{02 56 139 700 †
77 00 510 652

80 23 050 102

06 05 381 300

06 05 381 400

05 55 421 000

10 81 110 872

10 81 200 862

80 80 100 852



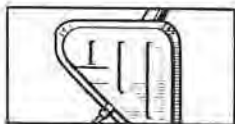

71 .01

B P.R. 810

71 .01

B P.R. 810

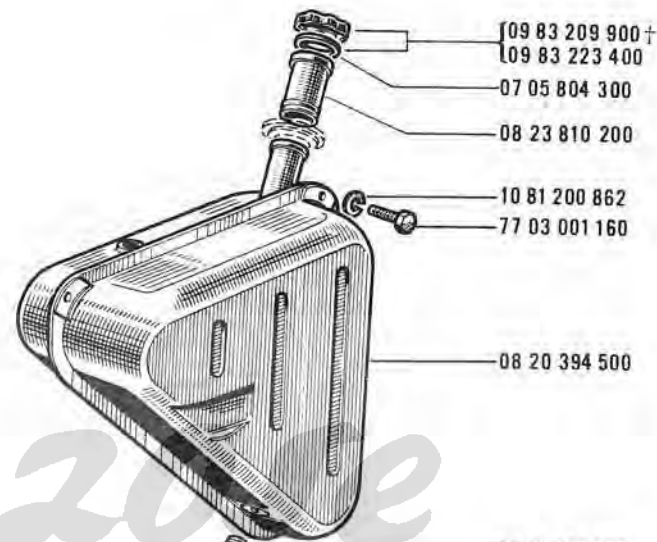

09 83 209 900 †
09 83 223 400

07 05 804 300

08 23 810 200

10 81 200 862

77 03 001 160

08 20 394 500

07 08 178 400

07 03 240 200

05 48 395 700

38 01 834 000 ▶◀ 4m

07 60 432 001 ✂ 1m

07 03 230 200

07 60 432 001 ✂ 1m

07 03 210 200

07 03 200 200

▶◀ 4m 38 01 834 000

06 07 492 300

DeFranzoni

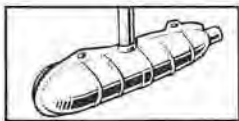

73.01

B P.R. 810

R.2134 / 10/11/15/18/20/21/22/24/26/27/28/29/41/100/101/103
R.2135 / 122/130/200/201/202/203/204/207/211/220/230/231/240

73.01

B P.R. 810

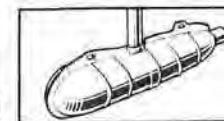

(a) 06 06 007 200 }
(b) 77 00 508 466 }

10 81 110 852

10 81 200 862

80 80 100 852

80 80 100 852

10 81 200 862

(a) 08 22 877 300 }
(b) 77 00 503 633 }

06 05 238 400

77 03 001 174

10 81 110 852

80 80 100 852

10 81 200 862

10 81 110 852

(a) † 08 21 547 700 }
(44)(b) 77 00 504 575 }

(a) 06 07 103 300 }
(b) 77 00 509 345 }

10 81 110 852

77 03 001 158

(a) 06 07 103 400 }
(b) 77 00 503 629 }

80 80 100 852

10 81 200 862

{ 08 21 553 200 (a)
{ 77 00 504 578 (b)

77 03 001 162

80 80 100 852

10 81 300 852

77 03 001 164

10 81 110 872

06 04 844 700

10 81 110 872

80 80 100 852

10 81 300 852

08 52 324 300

77 03 001 160

10 81 200 862

{ 05 54 822 000 (a)
{ 77 00 503 631 (b)

{ 77 03 001 173 (a)
{ 77 03 001 174 (b)

(a) VEH n° 1 ⇨ VEH n° 16401 [2]
(b) VEH n° 16402 ⇨ VEH n° ... [2]

[2] VEH n° 16389,16396
[44] VEH n° 1 ⇨ VEH n° 16401 [2]
77 01 452 152 -1-

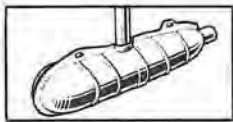

73.10

B P.R. 810

R.2134 / 12/13/14/30/40/42/70/80/81/84/86/88/89/102/120
R.2135 / 121/140/241/242/700/800/801/803/807/810/811

73.10

B P.R. 810

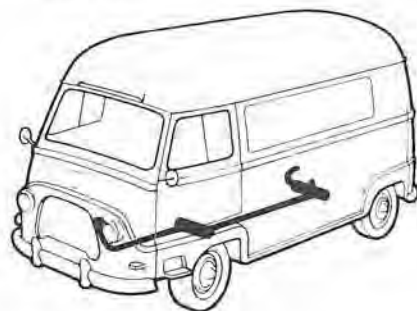
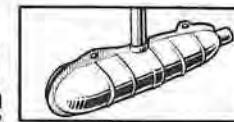

10 81 300 852
80 80 100 852
77 03 001 162
10 81 110 872

80 80 100 852
10 81 200 862
08 21 670 800
06 05 737 400
06 05 737 400
10 81 200 862
80 80 100 852
77 03 001 158

(c) 08 20 515 100 |
(45) (d) 77 00 504 801 |

10 81 200 862
80 80 100 852
(d) 77 00 508 389
(c) 05 55 687 400
10 81 110 852
77 03 001 174

(a)	VEH n°	1	⇨	VEH n° 2020
(b)	VEH n°	2021	⇨	VEH n°...
(c)	VEH n°	1	⇨	VEH n° 16401 (2)
(d)	VEH n°	16402	⇨	VEH n°... (2)

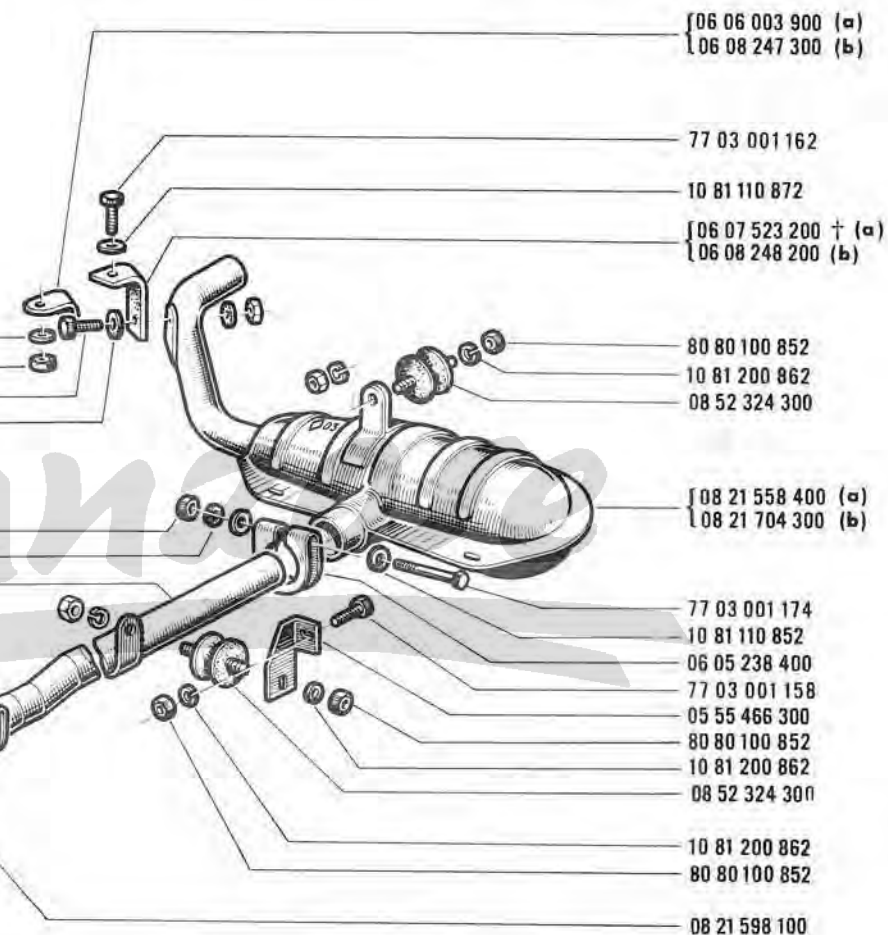

(2)	VEH n°	16389,16396
(45)	VEH n°	1 ⇨ VEH n° 16401 (2)
		77 00 508 387 -1-
		77 00 508 389 -1-
		77 00 509 485 -1-

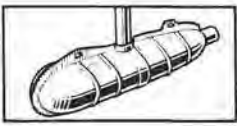

73.20

A P.R. 810

73.20

A P.R. 810

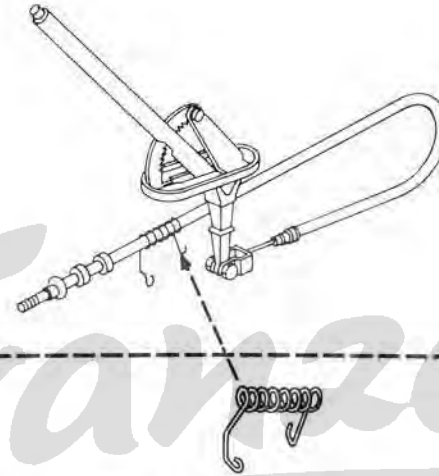
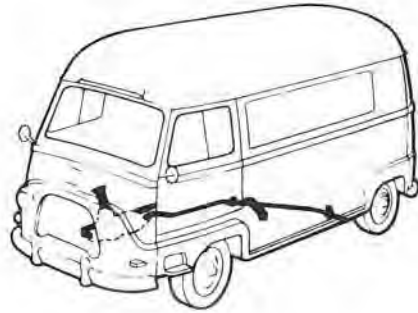
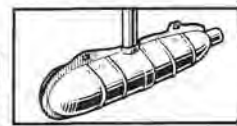

Der Franzose

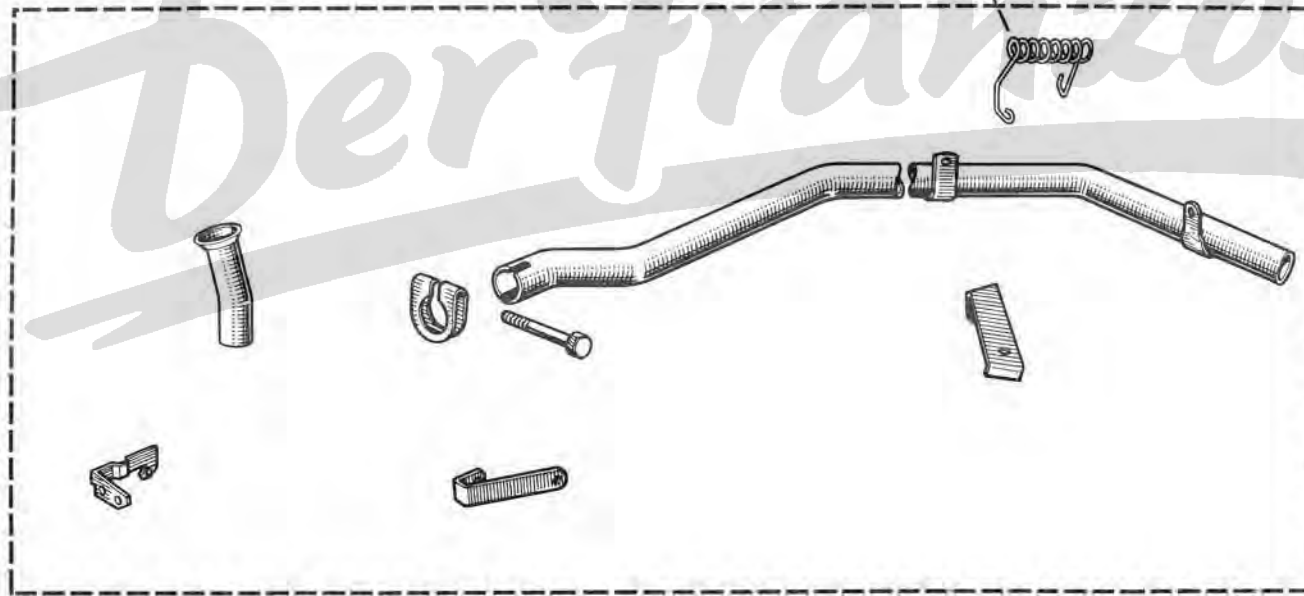

77 01 452 152

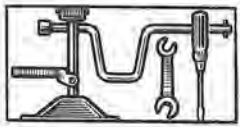

78.01

B P.R. 810

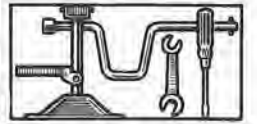

78.01

B P.R. 810

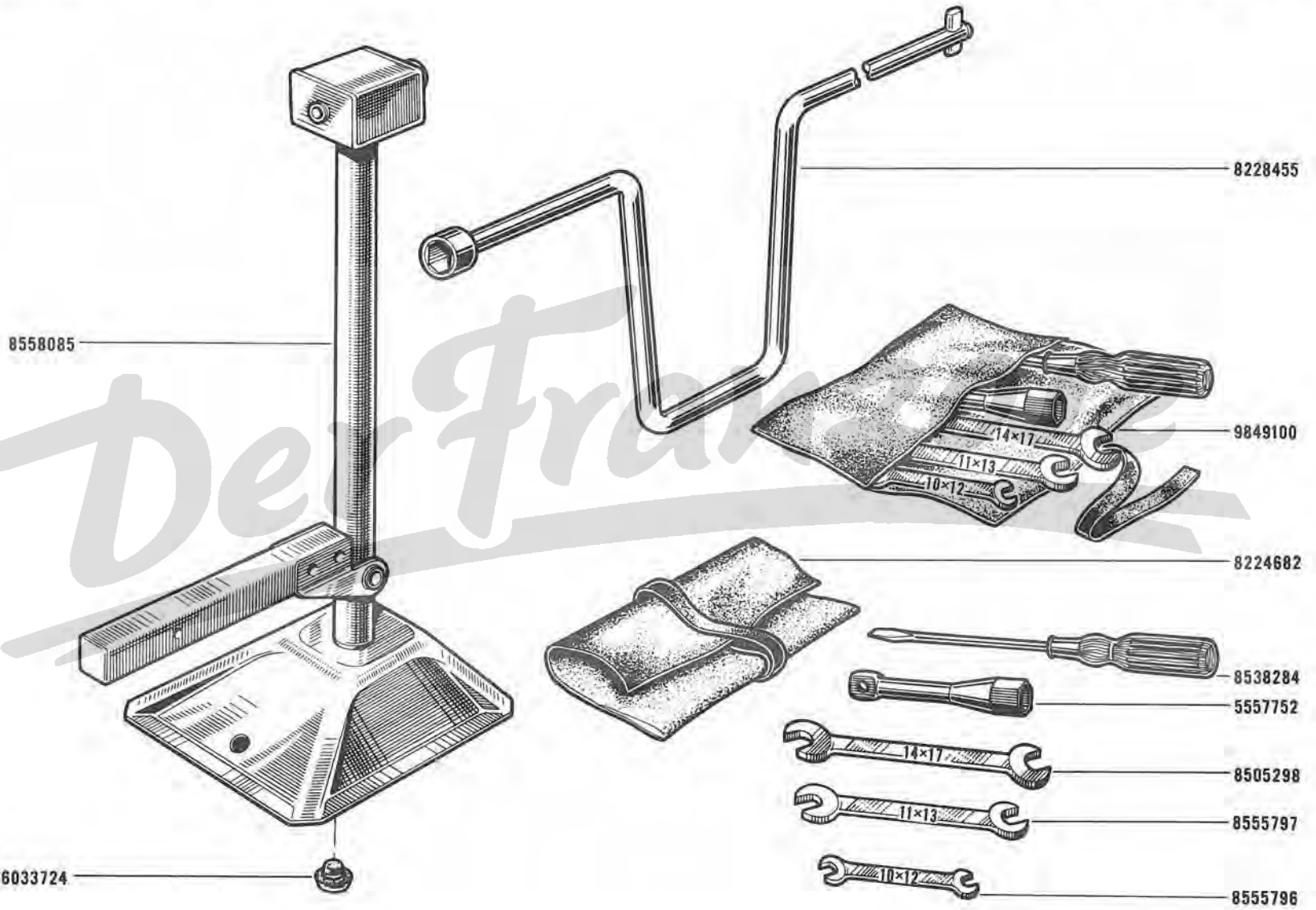



81.02.1

B P.R.810

81.02.1

B P.R.810



- 09 88 512 301 †
- 77 01 503 877 † (j)
- 77 01 508 141 (k)
- 09 88 512 300 †
- 77 01 503 876 † (m)
- 77 01 508 140 (n)
- 09 88 512 302 †

Der Franzose

- (a) { +09 88 505 300
- + 77 01 451 677
- (b) 77 01 453 026
- (c) { +09 88 505 301
- + 77 01 451 678
- (d) 77 01 453 027
- (e) { +09 88 505 304
- + 77 01 451 679
- (f) 77 01 453 028
- (g) 09 88 505 302
- (h) 09 88 505 303

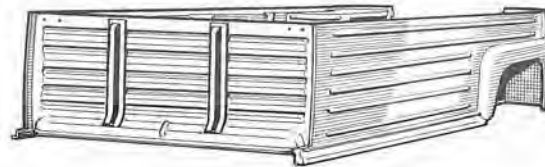

- [77 01 450 148 †
- [77 01 453 025 †



81.02.2

B P.R. 810

81.02.2

B P.R. 810



		?
(a)	R 2134 / 100/101/102/103/120/121/122/130 140/230/231/241/242	
	R 2134 /100/101/103/120/122/130/230/231	(63)(64)(67)
(b)	R 2134 /102	(63)(65)(67)
	R 2134 /121	(63)(64)(69)
	R 2134 /140/241/242	(63)(64)(68)
(c)	R 2134 /200/201/202/203/204/207/211/220	
(d)	R 2134 /200/201/202/203/204/207/211/220	(63)(64)(67)
(e)	R 2134 /240	
(f)	R 2134 /240	(63)(66)(68)
(g)	R 2134 /700	
(h)	R 2134 /800/801/803/807/810/811	
(j)	R 2134, R 2135 /41/240	
(k)	R 2134, R 2135 /41/240	(63)(66)(68)
(m)	R 2134 /10/11/12/13/14/15/18/20/21/22/24/26/27/28/29/30/40/42 R 2135 /100/101/102/103/120/121/122/130/140/200/201/202/203 204/207/211/220/230/231/241/242	
	R 2134 /10/11/12/15/18/20/21/22/24/26/27 R 2135 /28/29/100/101/103/120/122/130/200	(63)(64)(67)
(n)	R 2134, R 2135 /201/202/203/204/207/211/220/230/231 R 2134, R 2135 /13/102	(63)(65)(67)
	R 2134, R 2135 /14/121	(63)(64)(69)
	R 2134, R 2135 /30/40/42/140/241/242	(63)(64)(68)

- (63)
- (64)
- (65)
- (66) 06.01 ...
- (67)
- (68)
- (69)





81.05

B P.R. 810



81.05

B P.R. 810



† 09 92 018 600]
77 01 503 894]

04 27 751 500
† 08 21 331 000]
† 08 20 684 300]
77 00 505 090]

06 06 152 700
† 08 21 441 800]
77 00 505 883]

† 08 21 329 000]
† 08 21 736 200]
77 00 504 131]

08 24 408 800

08 20 514 200

08 24 426 900

1081 350852
77 03 001 160

† 08 21 482 300]
03 54 257 500]

08 21 396 200

† 08 21 327 900]
77 00 504 717]

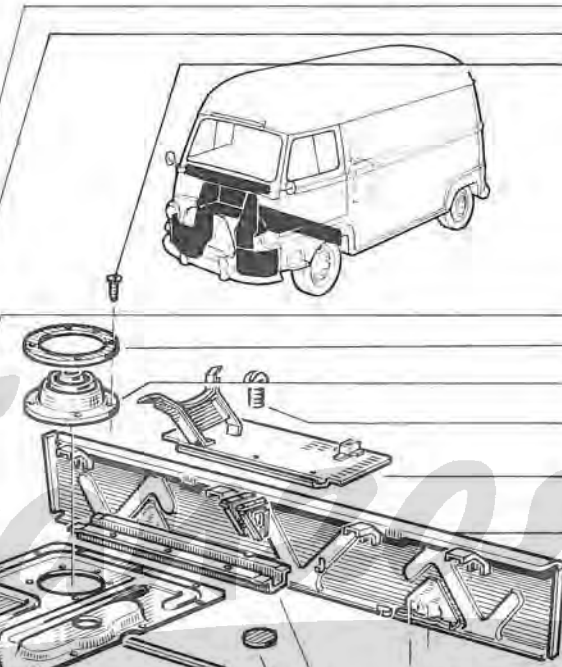
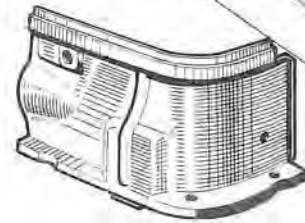
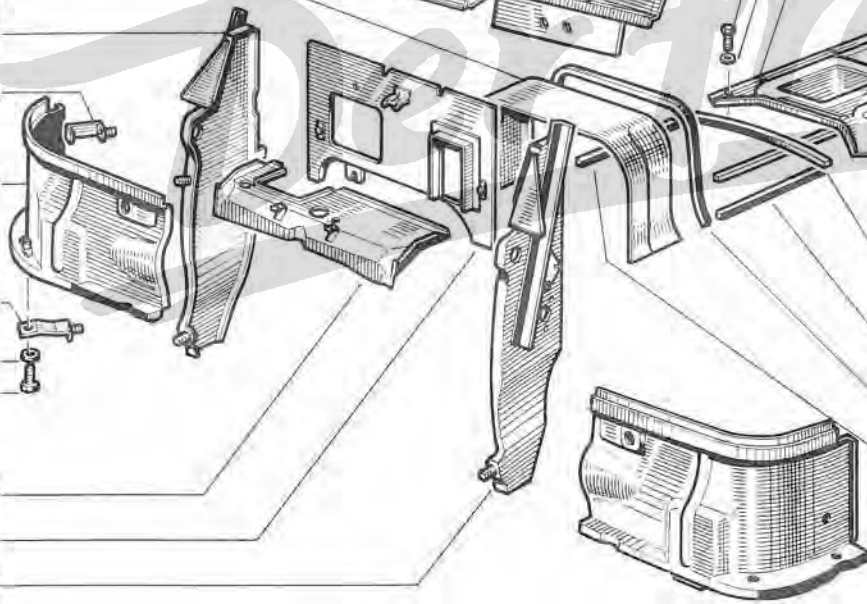
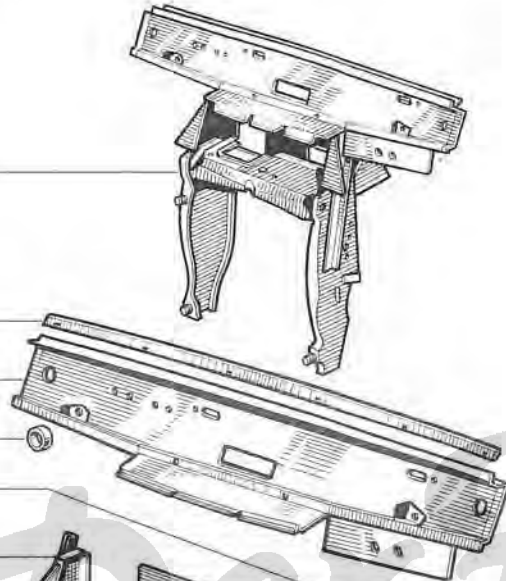

77 03 001 118
1081 340652
10 98 335 132

08 20 441 800
05 55 270 200
04 27 786 400
07 06 313 200

[04 27 689 200]
[08 21 670 000]

[08 21 411 600 (a)]
[08 21 757 500 (b)]

77 03 001 202
06 06 694 500
10 81 111 262
80 83 101 242

08 21 329 200
08 10 008 000
06 06 472 400
05 55 544 300
03 53 730 100
03 53 730 300
03 53 730 200
08 20 345 100

(a) VEH n° 1 ⇨ VEH n° 7264
(b) VEH n° 7265 ⇨ VEH n°



81.17

B P.R. 810

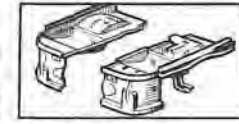

81.17

B P.R. 810

(a) 04 27 816 000
(b) 04 28 908 000

(a) 03 53 676 100
+ 03 54 323 511
(b) + 08 20 754 600
77 00 506 027

[07 06 271 900 †
77 03 001 122

1081 300652

[6046655 02 †
6075441 02

9926757

9926756

1098 542 132

[04 27 840 700 †
77 00 513 659

06 06 412 500

03 53 906 300

9930079

[0820 512 700 (a)
0820 741 400 (b)

[8204307
8203481

8213305

6057228

9930304

6064334

8206147

6063001

6063102

8242852

8206152

8205144

8213306

3537159

9930522

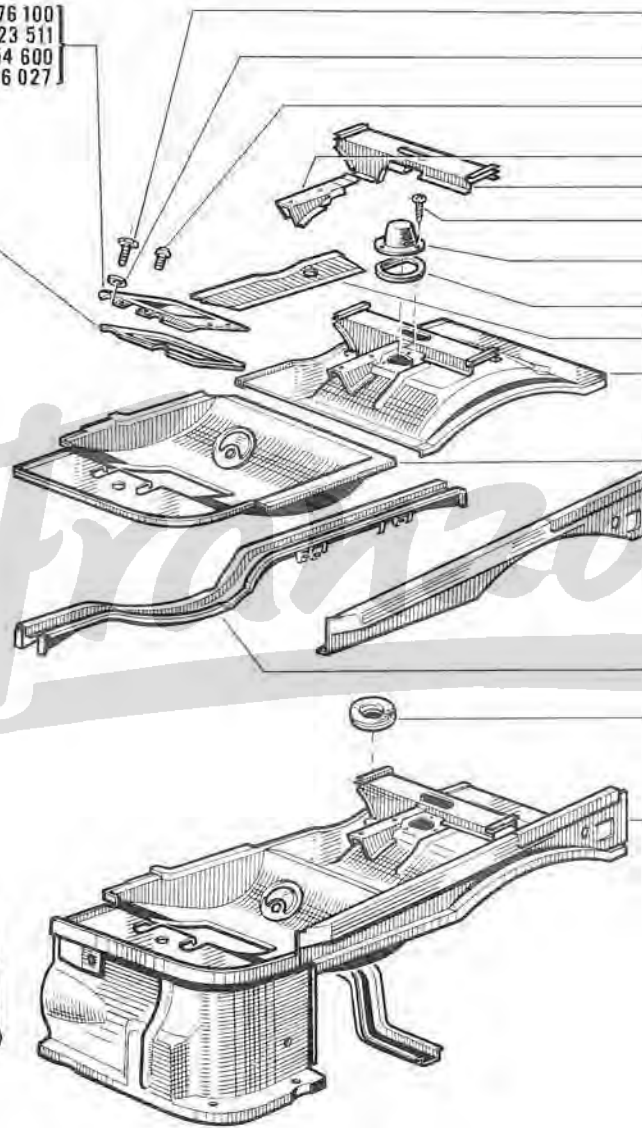

(a) VEH n° 1 ⇨ VEH n° 11966 [1]

(b) VEH n° 11967 ⇨ VEH n° ... [1]

[1] VEH n° 11915, 11921, 11934, 11948, 11949, 11952 ⇨ 11964



81.20

B P.R. 810



81.20

B P.R. 810

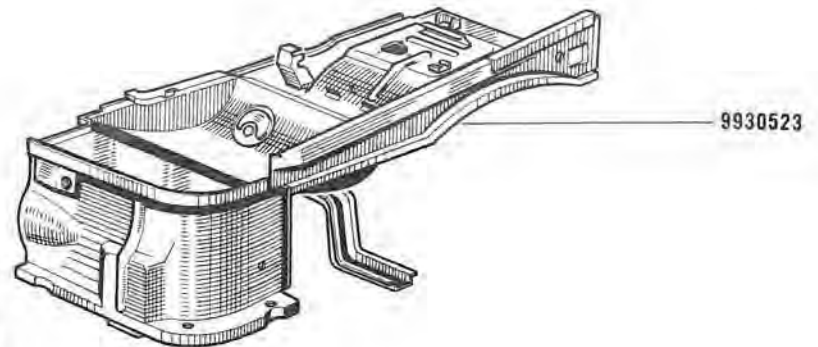
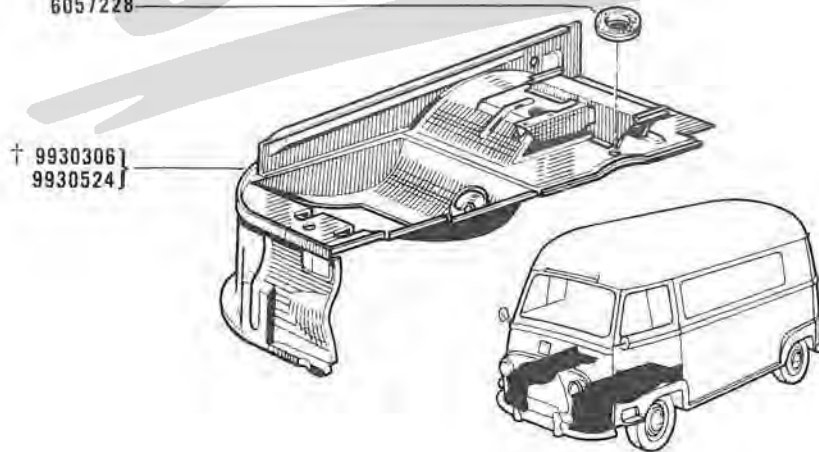
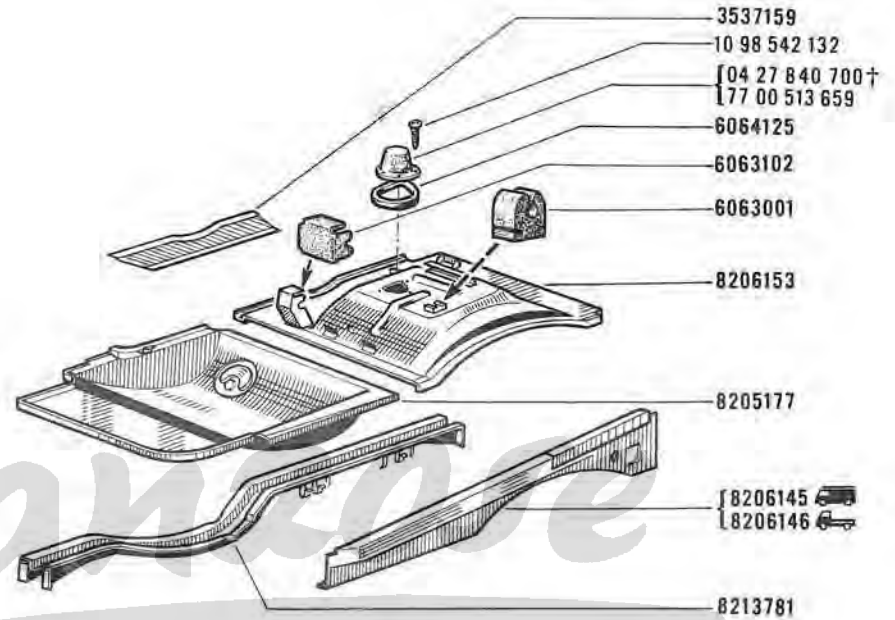
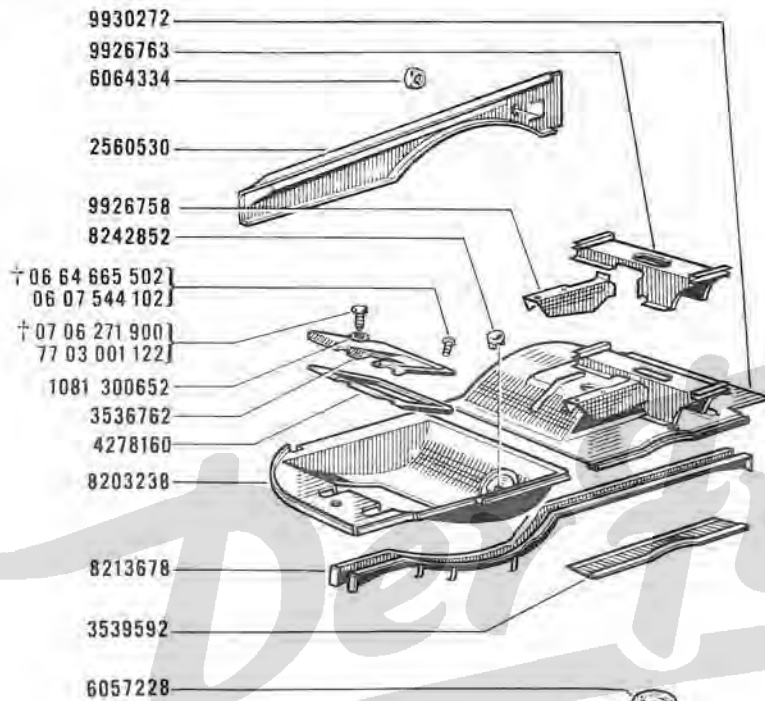



81.25

B P.R. 810



81.25

B P.R. 810

- 77 03 001 369
- 1081 350552
- 6073918
- 8227238

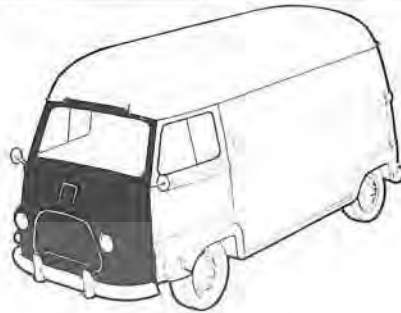

- 8080 100 452
- 1081 300 452
- 8023 040 102

- 6060514
- 8226054
- 5540876
- 8527202

- †08 21 476 300 |
- 77 00 504 718 |

- 1081 110 662
- 8080 200 652
- 1081 300652

8214764

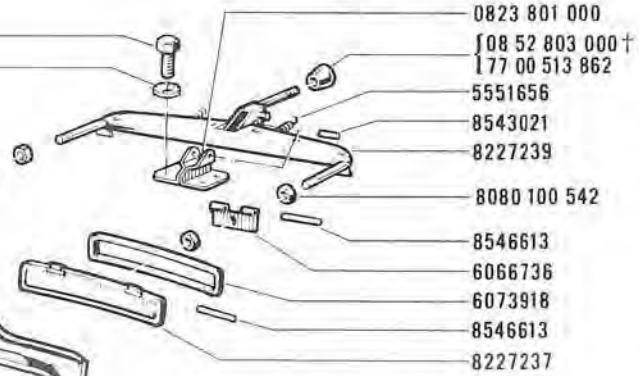

- 0823 801 000
- †08 52 803 000 †
- 177 00 513 862
- 5551656
- 8543021
- 8227239
- 8080 100 542
- 8546613
- 6066736
- 6073918
- 8546613
- 8227237

- 08 20 324 500
- 08 21 406 400 †
- 08 21 701 000 † (53) (a)
- 77 00 507 928
- 08 20 383 800 †
- 08 21 701 400 † (53) (b)
- 77 00 507 925
- 08 21 688 400 †
- 08 20 383 900
- 08 21 688 000 †
- 08 21 442 900 †
- 77 00 505 886 † (53) (c)
- 77 00 507 929
- 08 21 689 000 †
- 08 20 393 100 †
- 08 21 701 100 † (53) (d)
- 77 00 507 921

6062438

(a) R 2134 /240

(b) R 2134 /100/101/102/103/120/121/122/130/140/200/201
202/203/204/207/211/220/230/231/241/242

(c) R 2134 /41/240
R 2135

(d) R 2134 /10/11/12/13/14/15/18/20/21/22/24/26/27/28/29
R 2135 /30/40/42/100/101/102/103/120/121/122/130/140
200/201/202/203/204/207/211/220/230/231/241/242

(53) 77 01 001 149 -2-
77 01 001 150 -2-
77 01 005 248 -2-

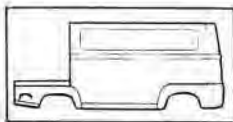

81.30

B P.R. 810



81.30

B P.R. 810

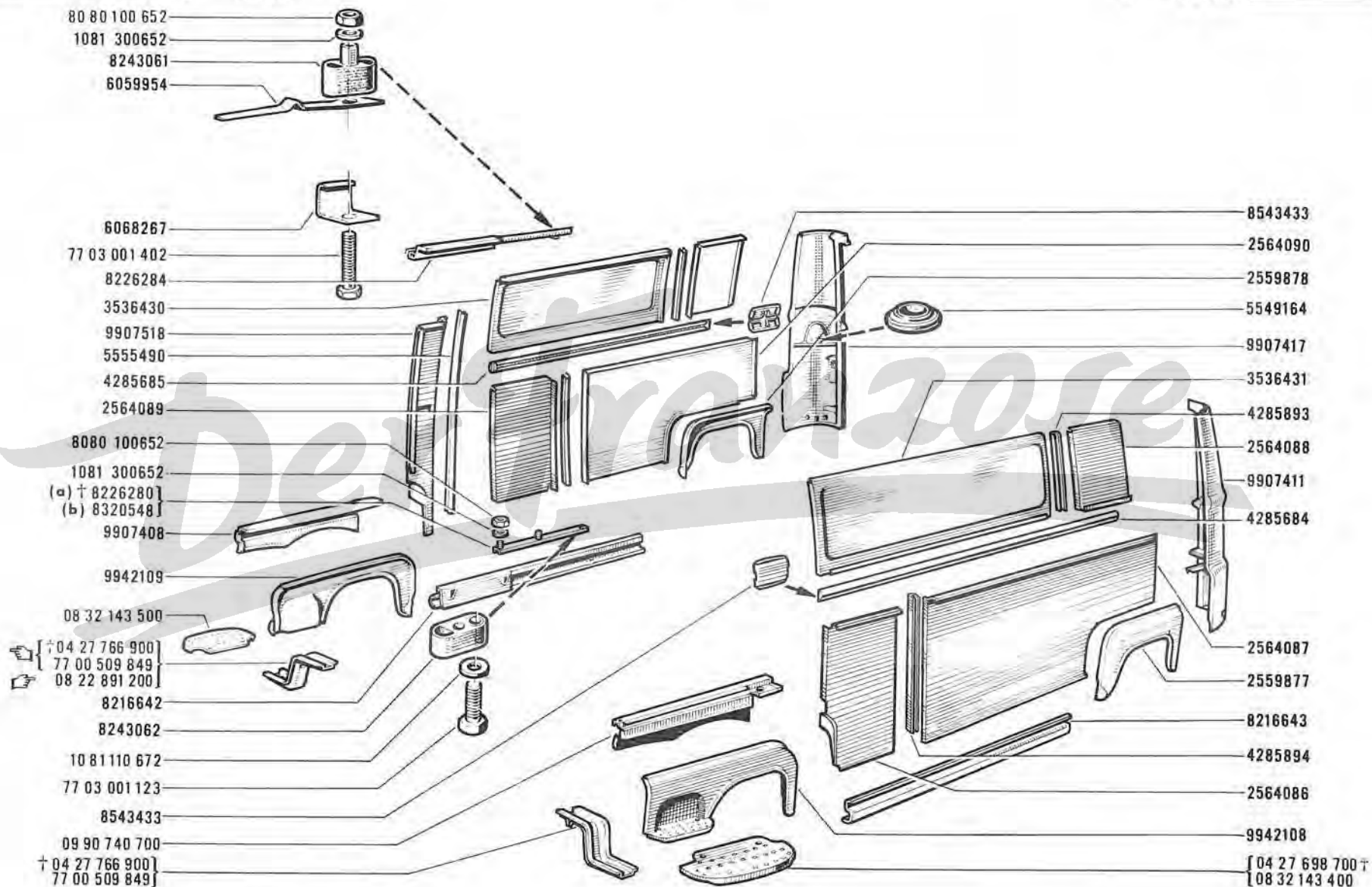
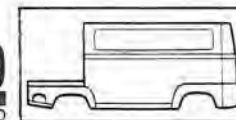

(a) VEH n° 1 ⇨ VEH n° 2122
 (b) VEH n° 2123 ⇨ VEH n°

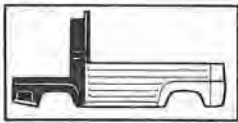

81.35

A P.R. 810

R.2134 

81.35

A P.R. 810

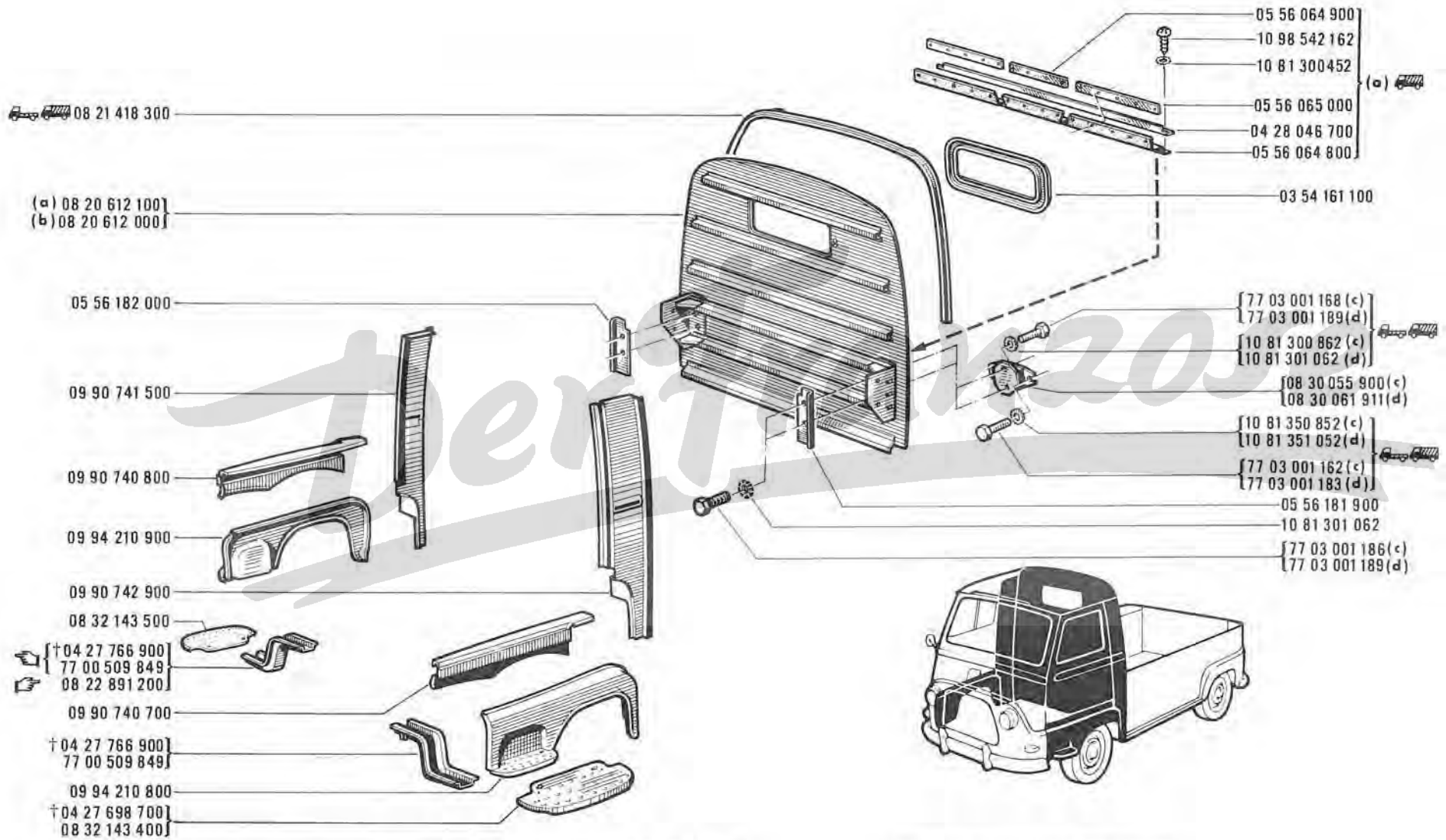
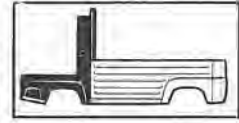

(a) R.2134/200/201/202/203/204/206/207/211/800/801/803/807/810/811



(b) R.2134/100/101/102/120/121/122/130/140/230/240/241/242/700

(c) VEH n° 1 ⇨ VEH n° 13195

(d) VEH n° 13196 ⇨ VEH n°...



81.36
A P.R. 810

R.2134  

81.36
A P.R. 810

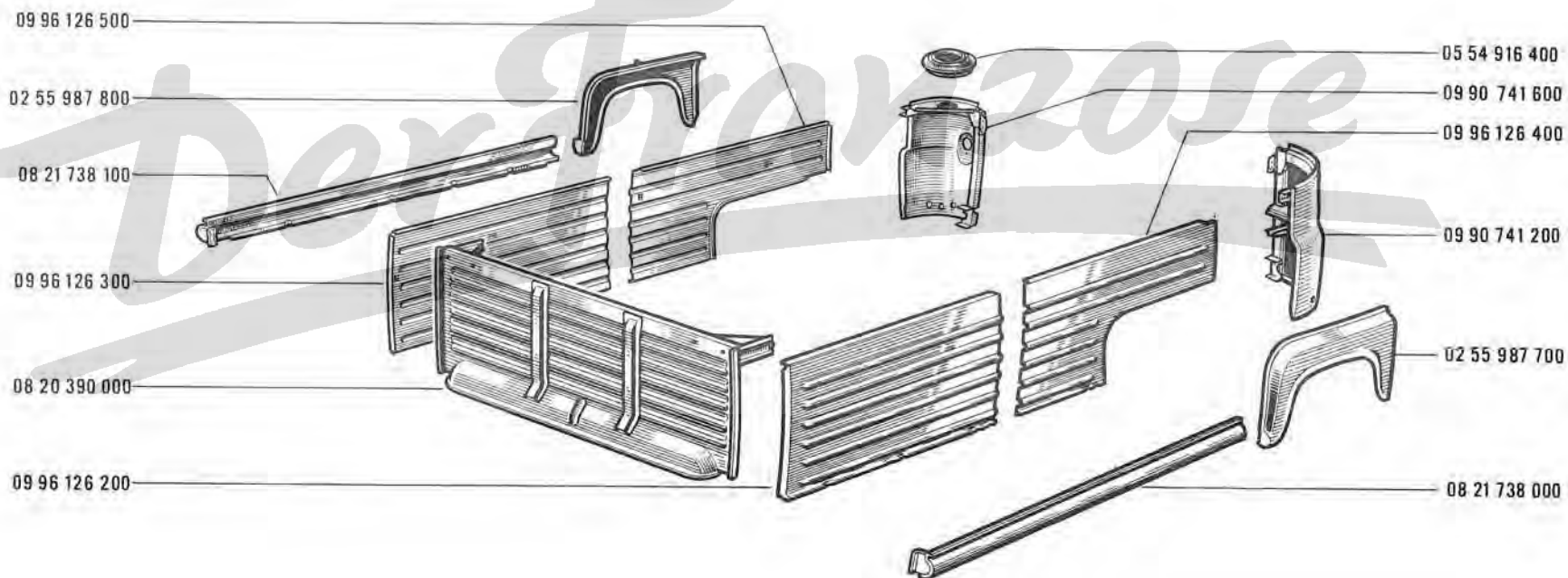
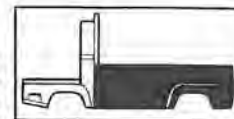

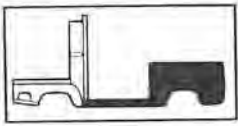

81.38

A P.R. 810

R 2134 

81.38

A P.R. 810

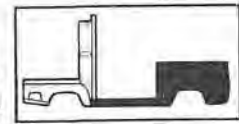

09 90 742 800

08 21 738 300

02 55 987 800

08 21 738 200

05 54 916 400

09 90 748 600

09 90 741 300

09 90 742 700

02 55 987 700

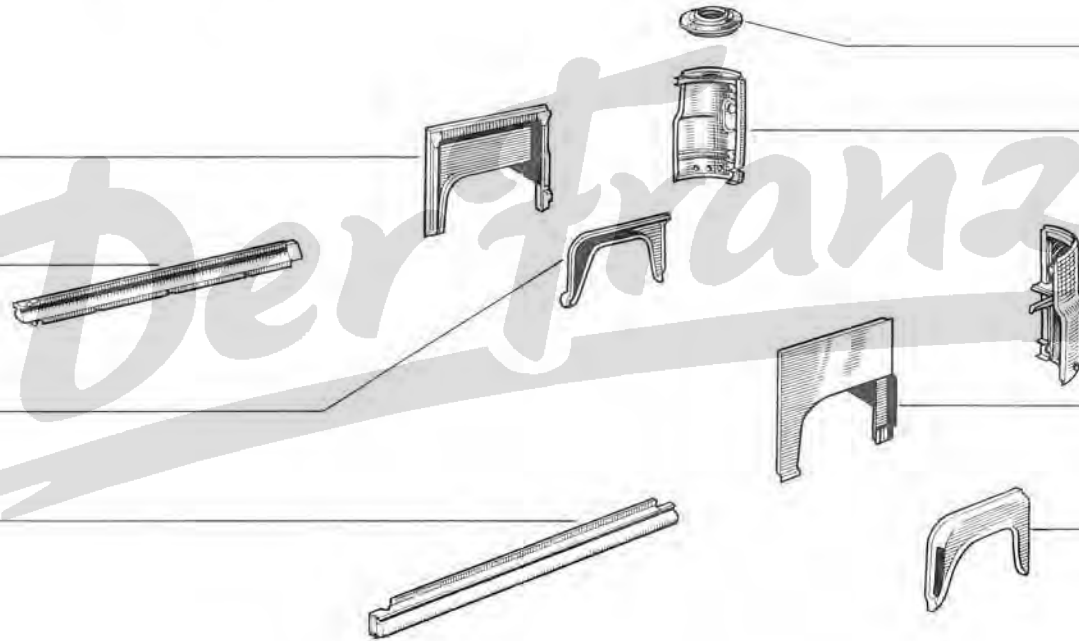

Derfranzose

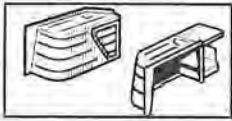

81.40

B P.R.810

81.40

B P.R.810

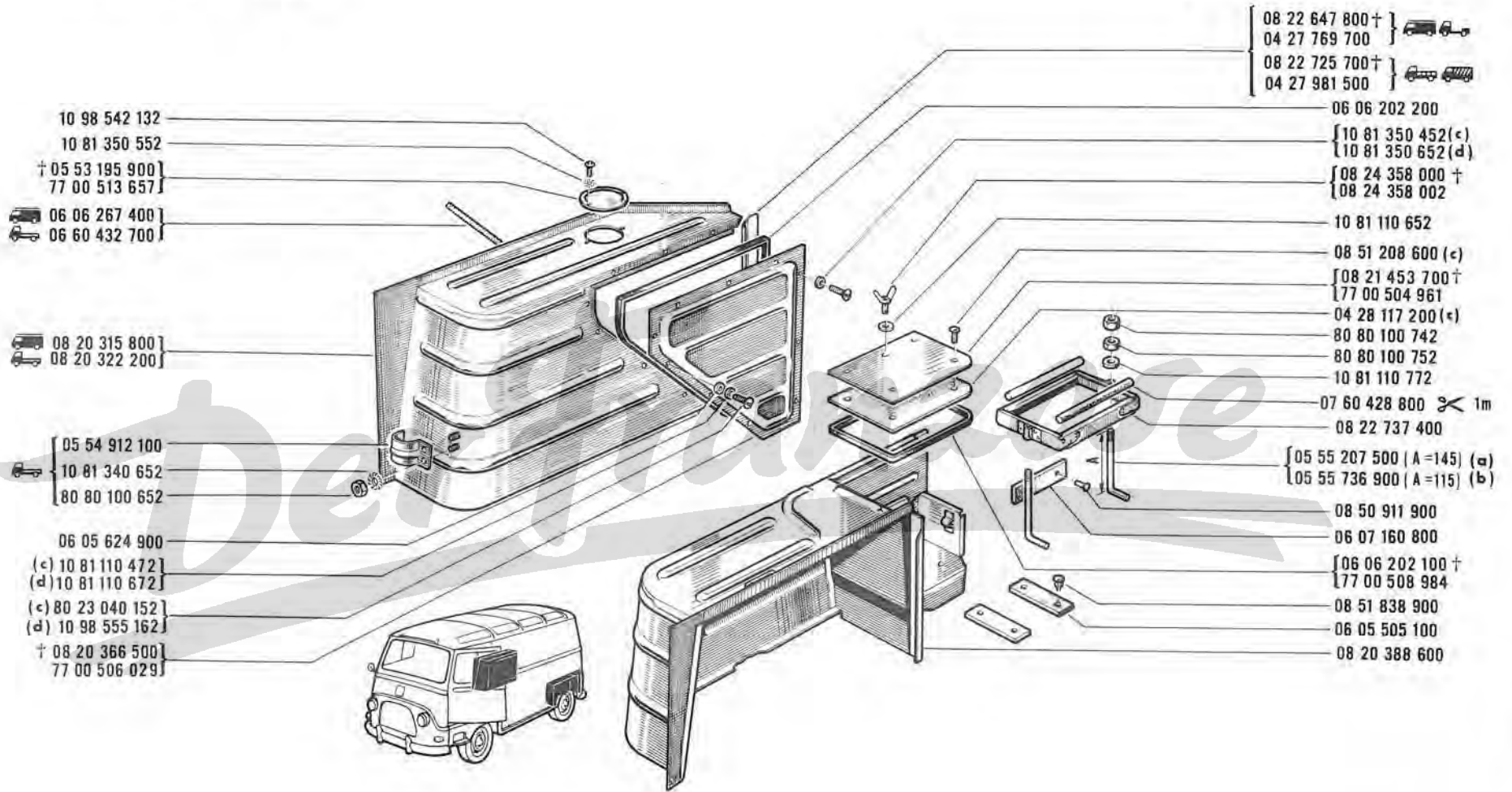

(a)	/30/40/41/42/140/240/241/242
(b)	10/11/12/13/14/15/18/20/21/22/24/26/27/28/29/70/80/81/84 86/88/89/100/101/102/103/120/121/122/130/200/201/202/203 204/207/211/220/230/231/700/800/801/803/807/810/811

(c)	VEH n° 1 ⇨ VEH n° 15245
(d)	VEH n° 15246 ⇨ VEH n° ...

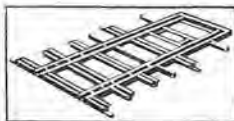

81.45

B P.R. 810

81.45

B P.R. 810

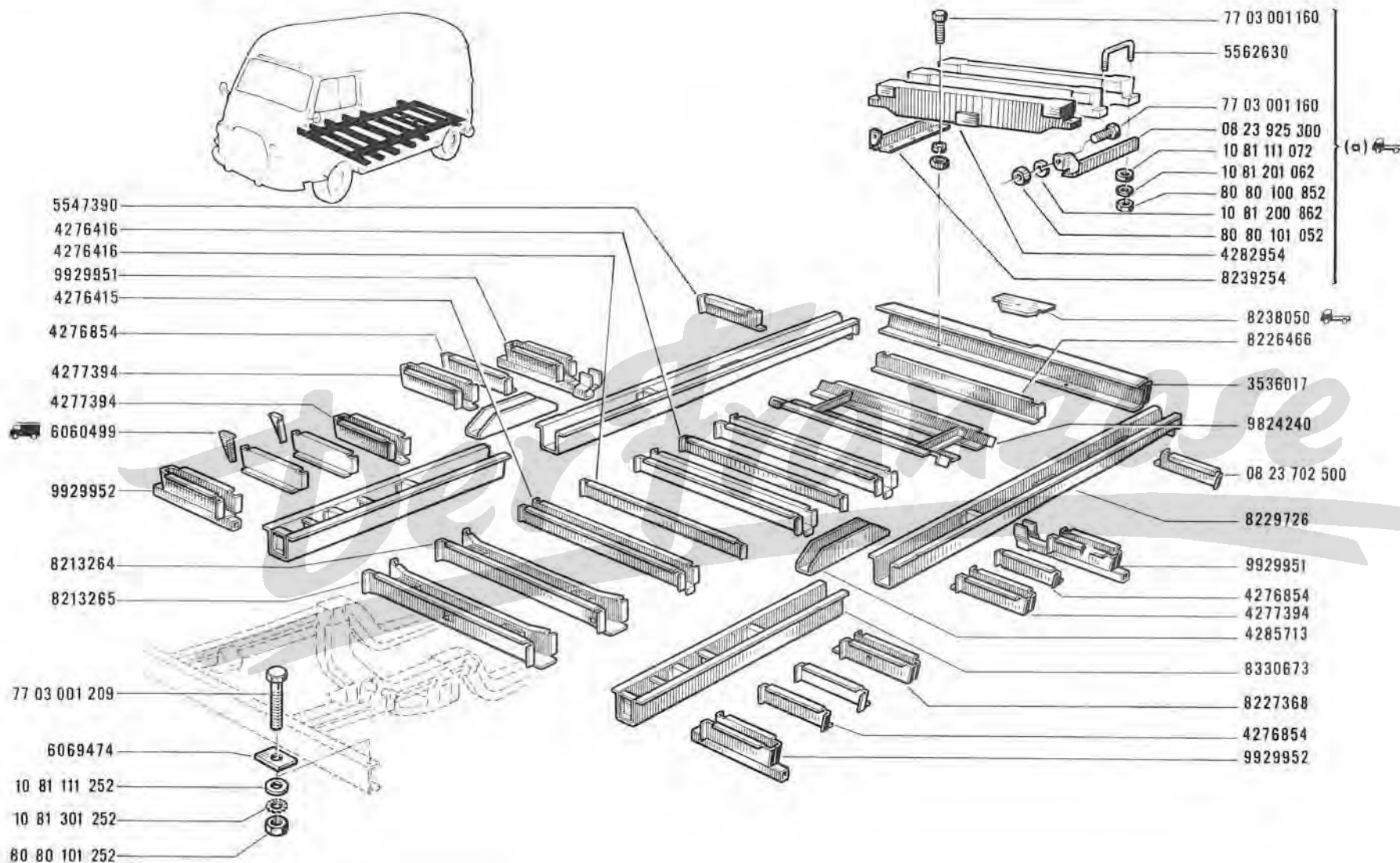
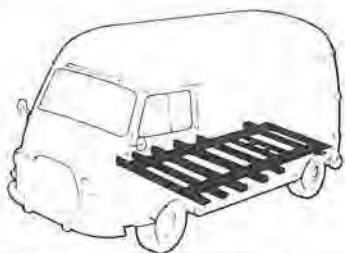
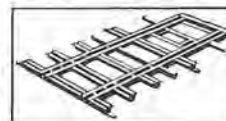

(a) R. 2134/140



81.46

B P.R. 810

81.46

B P.R. 810

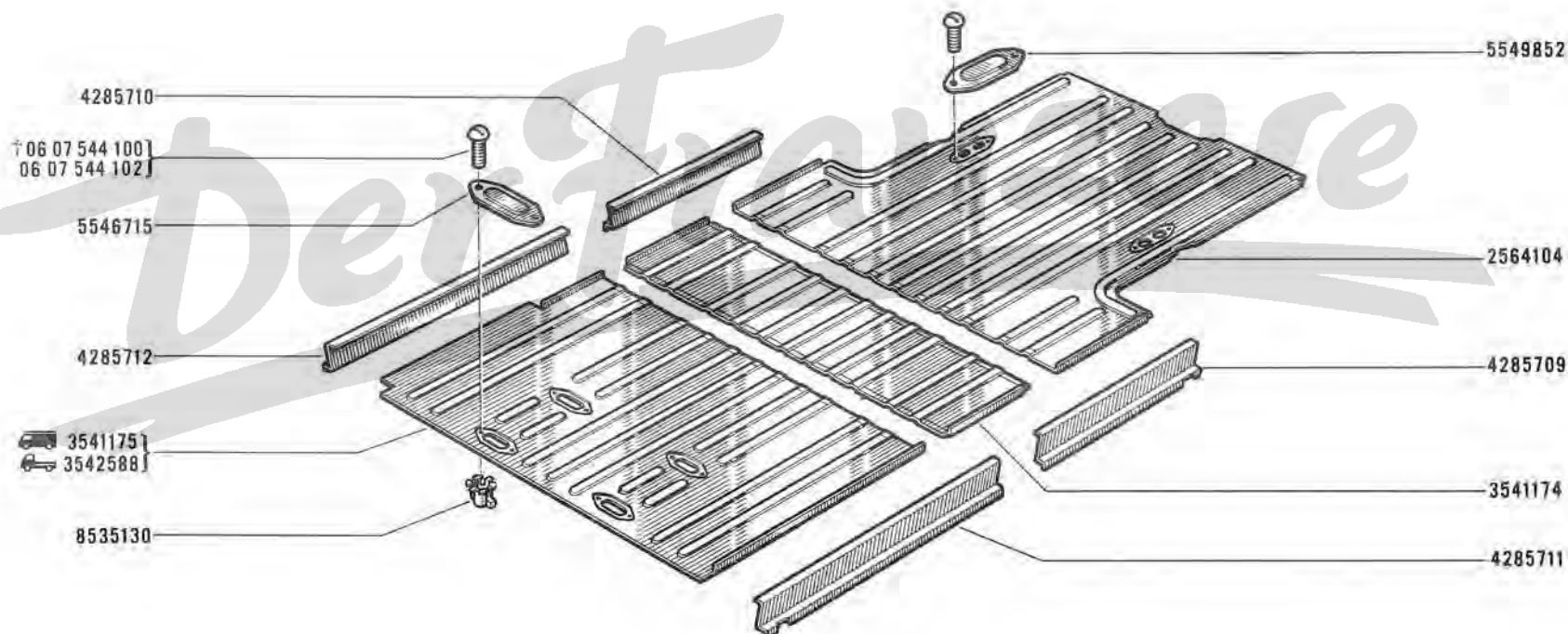
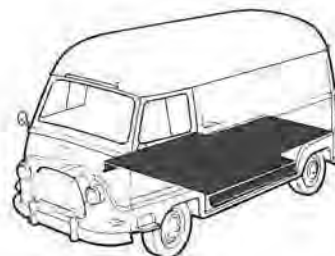

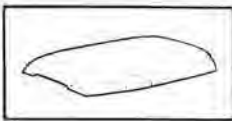

81.50

B P.R. 810



81.50

B P.R. 810

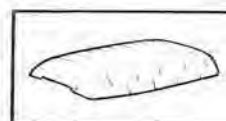

09 90 741 800

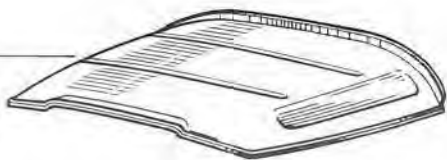

8546060

8546059

2563882

2564083

10 81 110 572

3541151

3540856

3540854

3540855

3540853

05 55 131 100

05 55 131 200

2563949

3537962

3541149

9907421

2561188

3541150

3541148

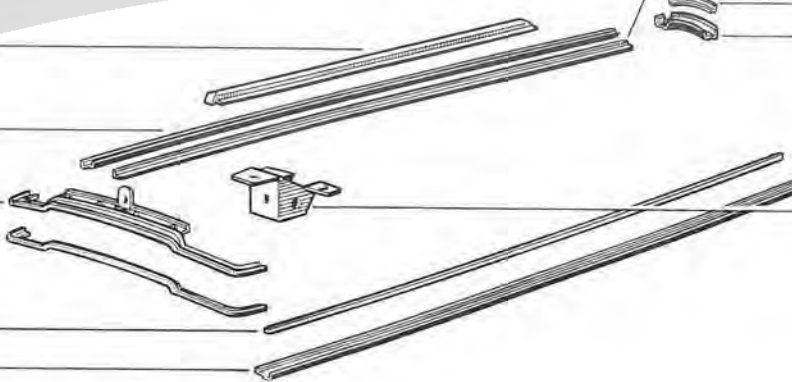
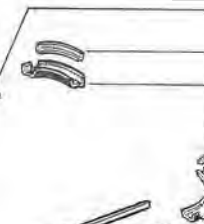
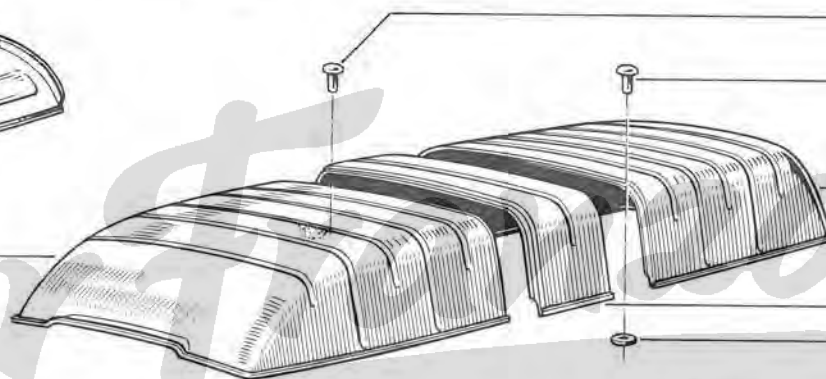



81.52

A P.R. 810

R 2134 

81.52

A P.R. 810

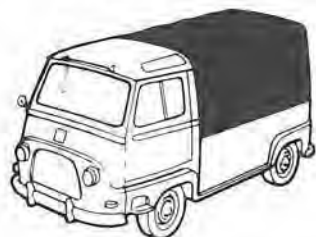

8214164

8320915

77 03 001 162

10 81 300 852

77 03 001 017

06 06 704 800

10 81 300 552

80 80 100 542

09 98 774 700

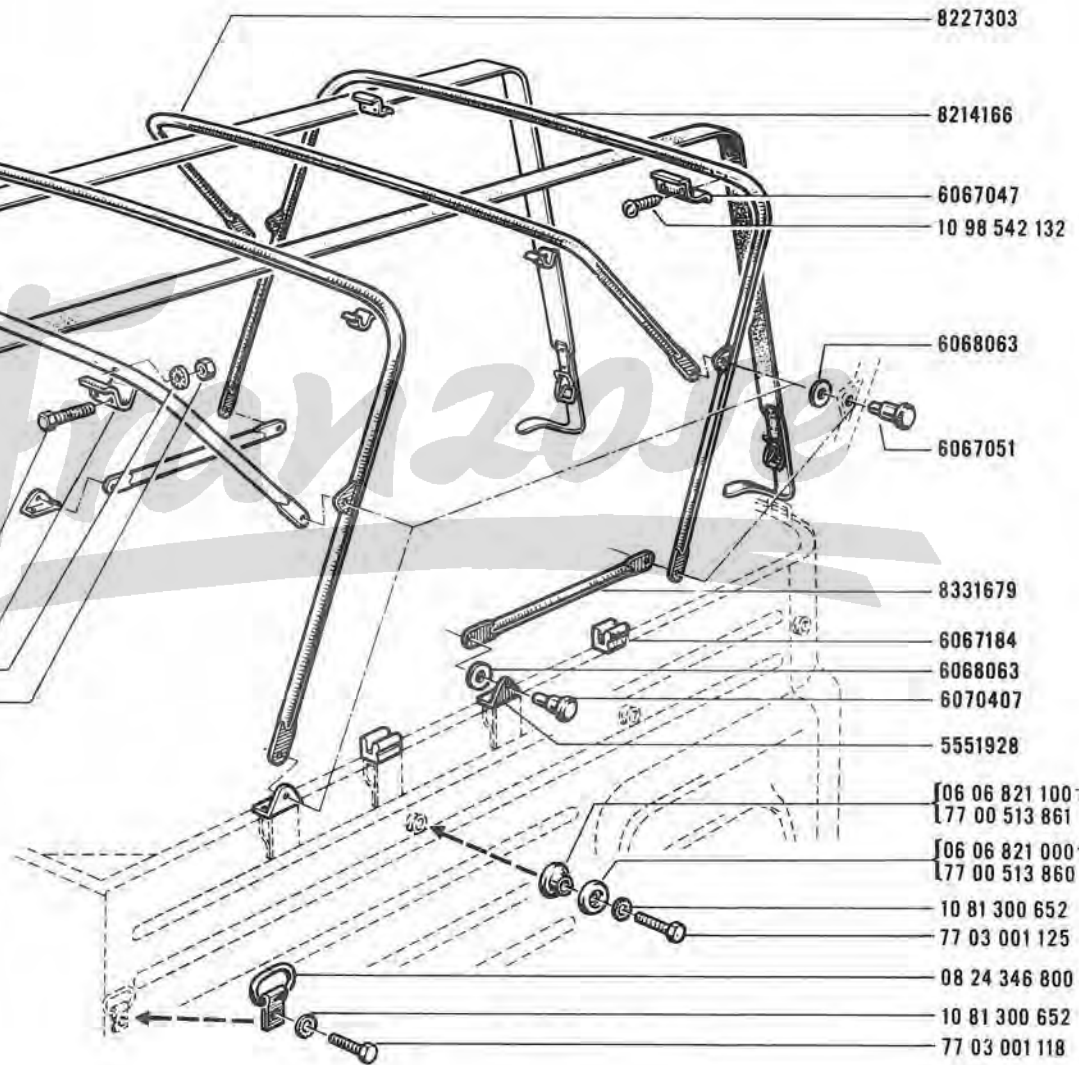
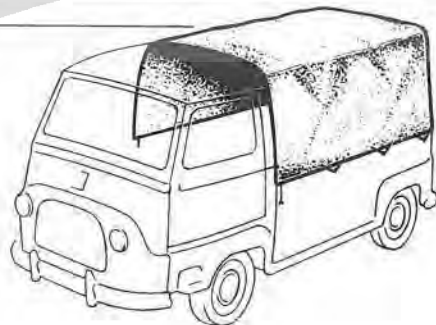

8227303

8214166

6067047

10 98 542 132

6068063

6067051

8331679

6067184

6068063

6070407

5551928

[06 06 821 100+

[77 00 513 861

[06 06 821 000+

[77 00 513 860

10 81 300 652

77 03 001 125

08 24 346 800

10 81 300 652

77 03 001 118

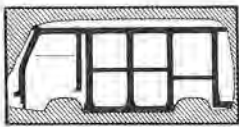

81.67

B P.R.810



81.67

B P.R.810

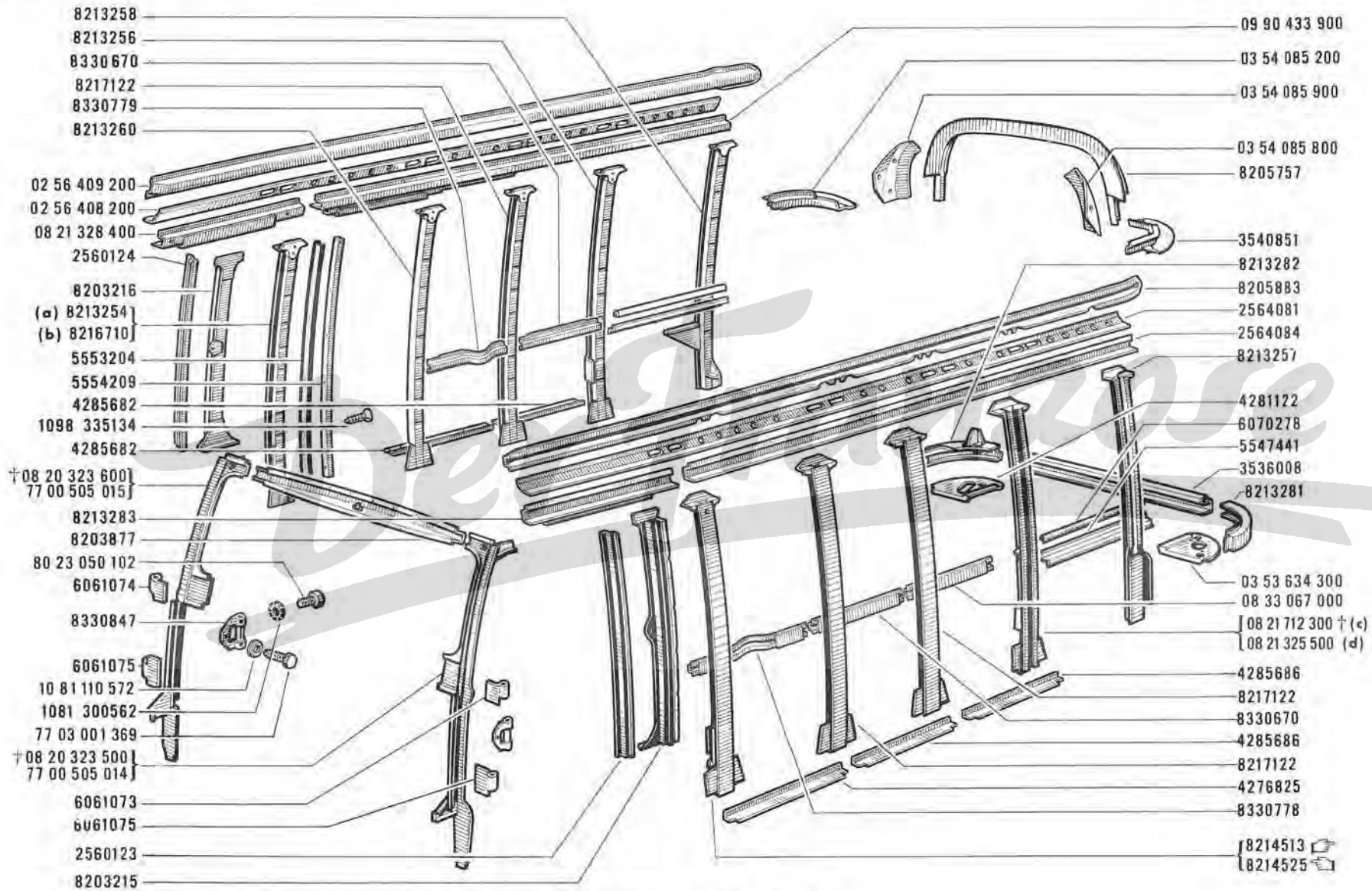
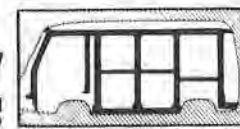

- (a) VEH n° 1 ⇨ VEH n° 7264
(b) VEH n° 7265 ⇨ VEH n° ...
(c) VEH n° 1 ⇨ VEH n° 14262
(d) VEH n° 14263 ⇨ VEH n° ...



81.70

A P.R. 810

R 2134 

81.70

A P.R. 810



2560124

8203877

† 08 20 323 600 |
77 00 505 015 |

6061074

6061075

8330847

1081 300562

80 23 050 102

10 81 110 572

77 03 001 369

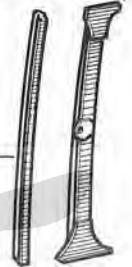

8213284

8203216

8213938

8213283

8213937

8203215

2560123

6061073

6061075

† 08 20 323 500 |
77 00 505 014 |

Der Franzose

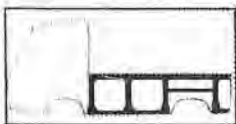

81.75

A P.R. 810

R 2134  

81.75

A P.R. 810

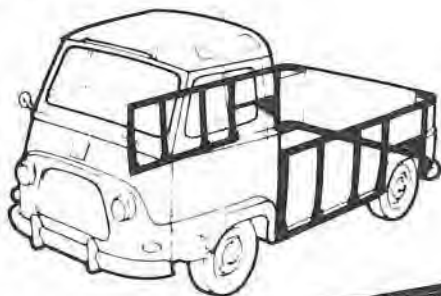
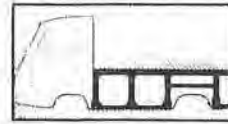

(a) 08 21 748 200
(b) 08 21 795 600

8214087

8214086

8217369

8213378

8213380

(a) 08 21 748 100
(b) 08 21 795 500

8214087

8214087

8214085

4288111

4277916

8213282

4281122

6029382

6066786

4277101

8528292

6066787

8213259

8213281

3536343

05 53 195 900 +
77 00 513 657

10 98 542 132

5483957

8213379

6070278

5547441

8213377

4288113

4288113

(a) VEH n° 1 ⇨ VEH n° 13195

(b) VEH n° 13196 ⇨ VEH n° ...

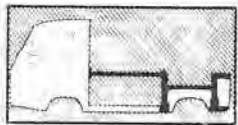

81.77

A P.R. 810

R 2134 

81.77

A P.R. 810

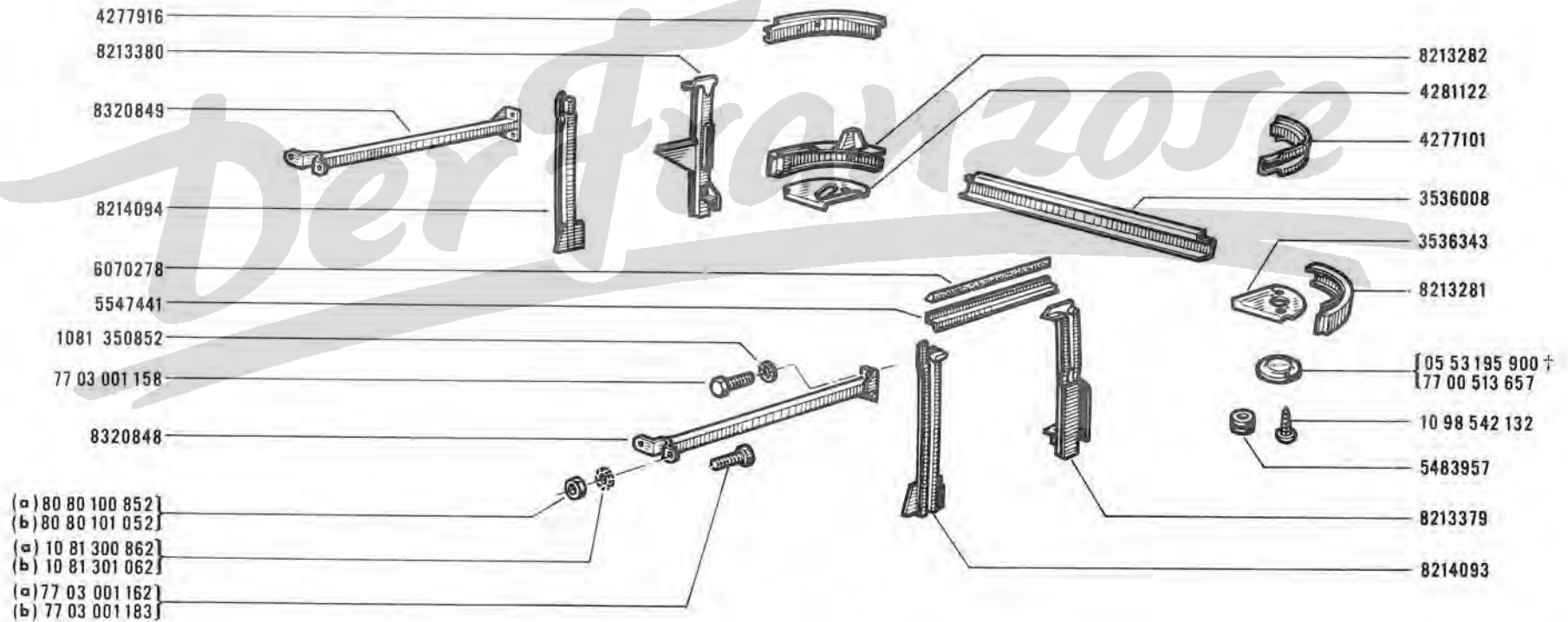
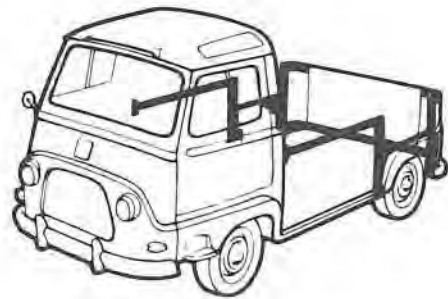
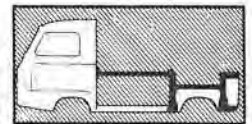

(a) VEH n° 1 ⇨ VEH n° 13195

(b) VEH n° 13196 ⇨ VEH n° ...



81.80

B P.R.810



81.80

B P.R.810

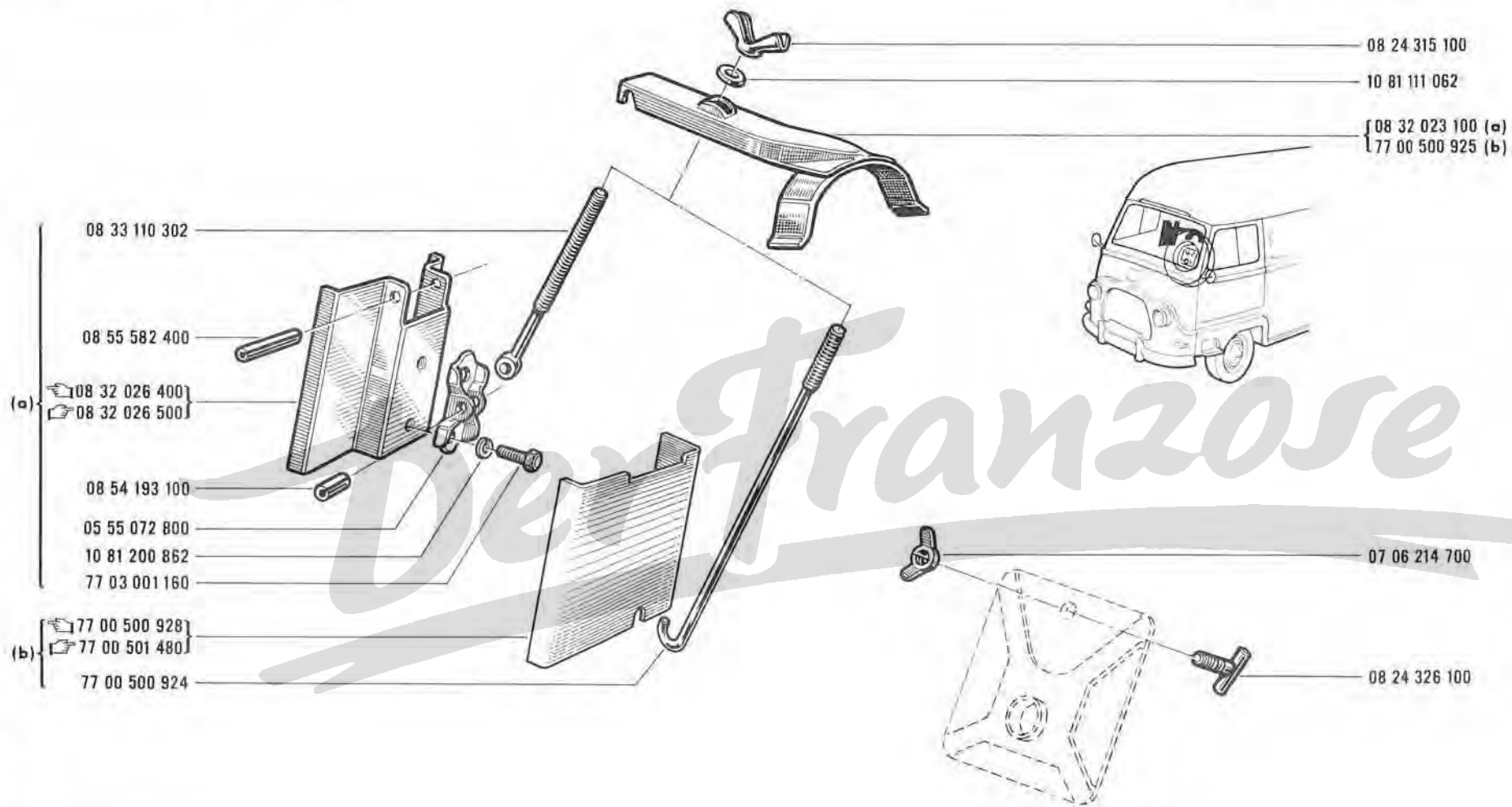
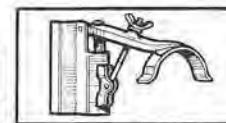

(a) VEH n° 1 ⇨ VEH n° 16750

(b) VEH n° 16751 ⇨ VEH n° ...



81.90

A P.R. 810

R 2134  

81.90

A P.R. 810

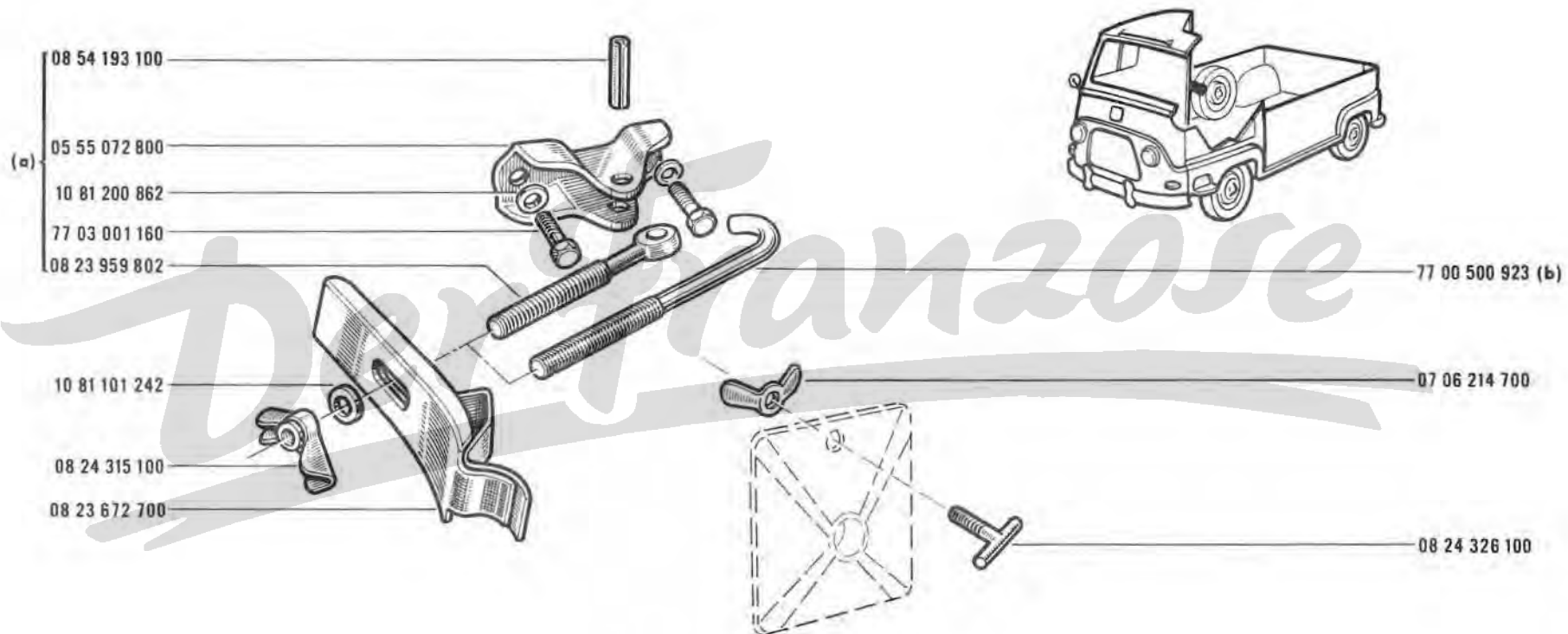

(a) VEH n° 1 ⇨ VEH n° 16750

(b) VEH n° 16751 ⇨ VEH n° ...



82.05

B P.R. 810



82.05

B P.R. 810

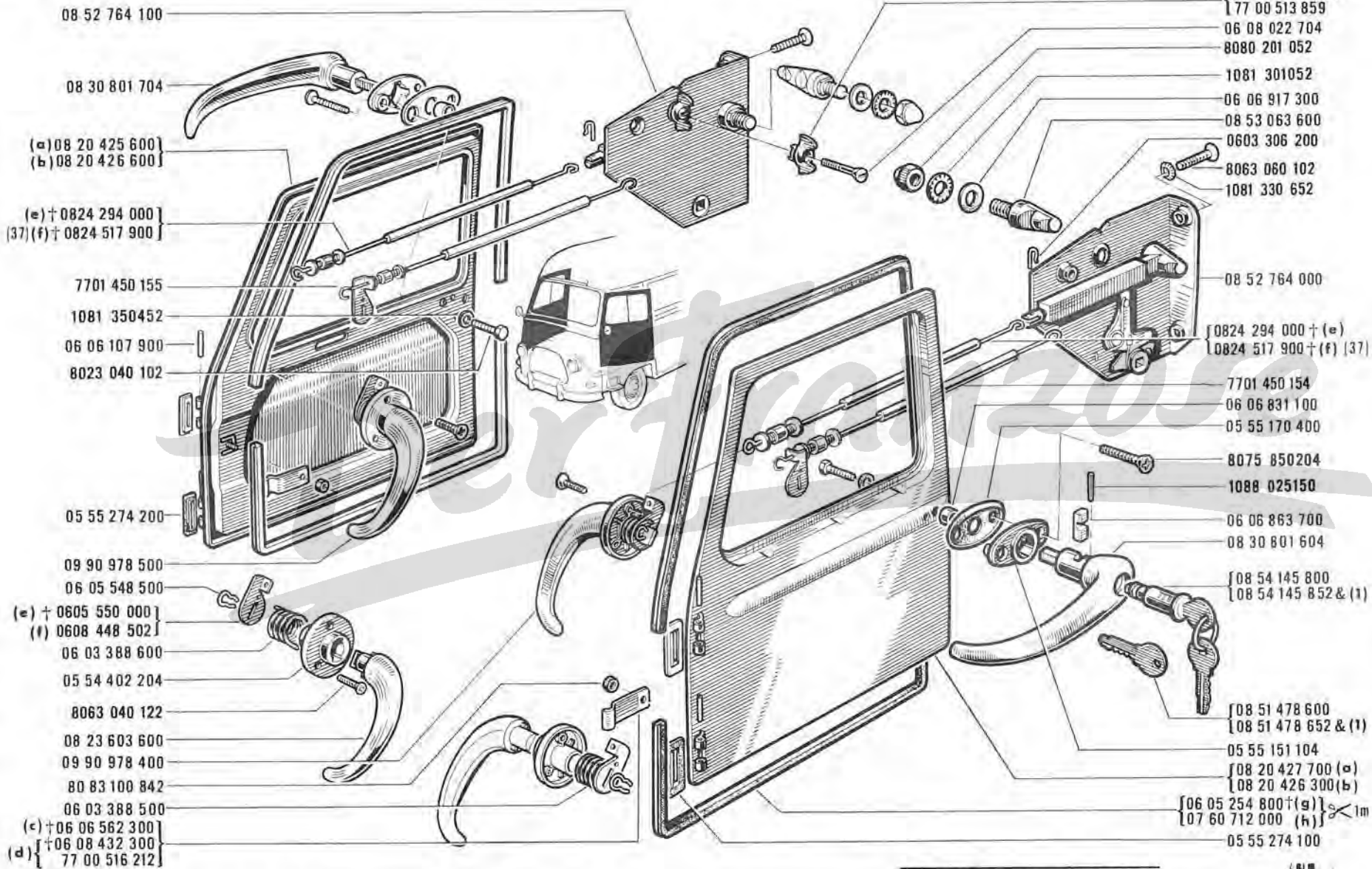

(a) /15/30/40/41/42/122/140/240/241/242

(b) /10/11/12/13/14/18/20/21/22/24/26/27/28/29/100/101/102/103
120/121/130/200/201/202/203/204/207/211/220/230/231

(c) VEH n° 1 ⇨ VEH n° 9743

(d) VEH n° 9744 ⇨ VEH n° ...

(e) VEH n° 1 ⇨ VEH n° 12172

(f) VEH n° 12173 ⇨ VEH n° ...

(g) VEH n° 1 ⇨ VEH n° 13149

(h) VEH n° 13150 ⇨ VEH n° ...

(37) VEH n° 1 ⇨ VEH n° 12172

06 08 448 502 -1-

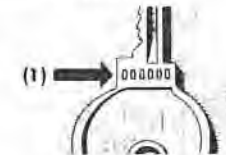



82.10
B PR 810



82.10
B PR 810

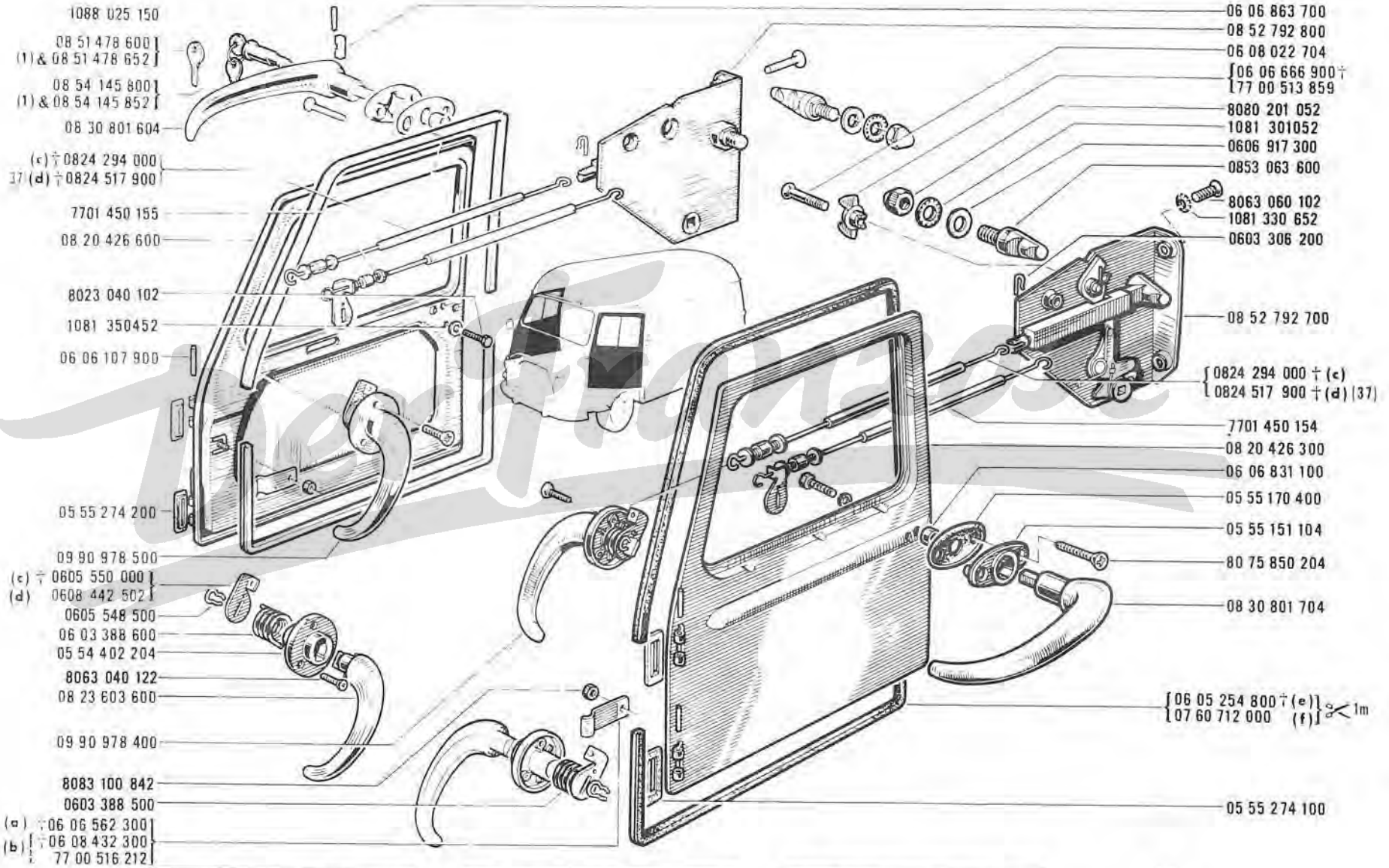

(a) VEH n° 1 ⇨ VEH n° 9743
 (b) VEH n° 9744 ⇨ VEH n° ...
 (c) VEH n° 1 ⇨ VEH n° 12172

(d) VEH n° 12173 ⇨ VEH n° ...
 (e) VEH n° 1 ⇨ VEH n° 13149
 (f) VEH n° 13150 ⇨ VEH n° ...

(37) VEH n° 1 ⇨ VEH n° 12172
 ⇨ 06 08 448 502 -1-





82.15

B P.R. 810



82.15

B P.R. 810

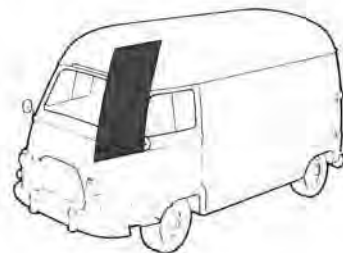

08 20 331 800

08 30 018 300

80 75 850 204

05 55 151 104

(a) † 06 06 512 200

(b) 08 30 052 900

08 23 685 100

06 06 180 200

06 04 407 700

10 81 110 652

80 80 100 642

10 81 310 652

† 06 05 995 309

06 05 995 302

08 22 660 000

05 55 020 400

06 06 430 000

80 75 060 202

10 81 320 652

10 81 110 852

(a) VEH n° 1 ⇨ VEH n° 4129

(b) VEH n° 4130 ⇨ VEH n° ...



82.21

B P.R. 810



82.21

B P.R. 810



- 08 33 050 400
- 05 55 898 800
- 08 20 571 600



- 08 52 949 900

- 8083 100 552

- (a) 0853 971 1001
- (b) 0857 697 6001

- 77 03 001 009
- 1081 300 552
- 08 54 380 500
- 1081 350552
- 8023 050 102
- 77 03 001 369
- 1081 300552
- 08 54 380 400
- 1081 111 052
- 8080 101 052

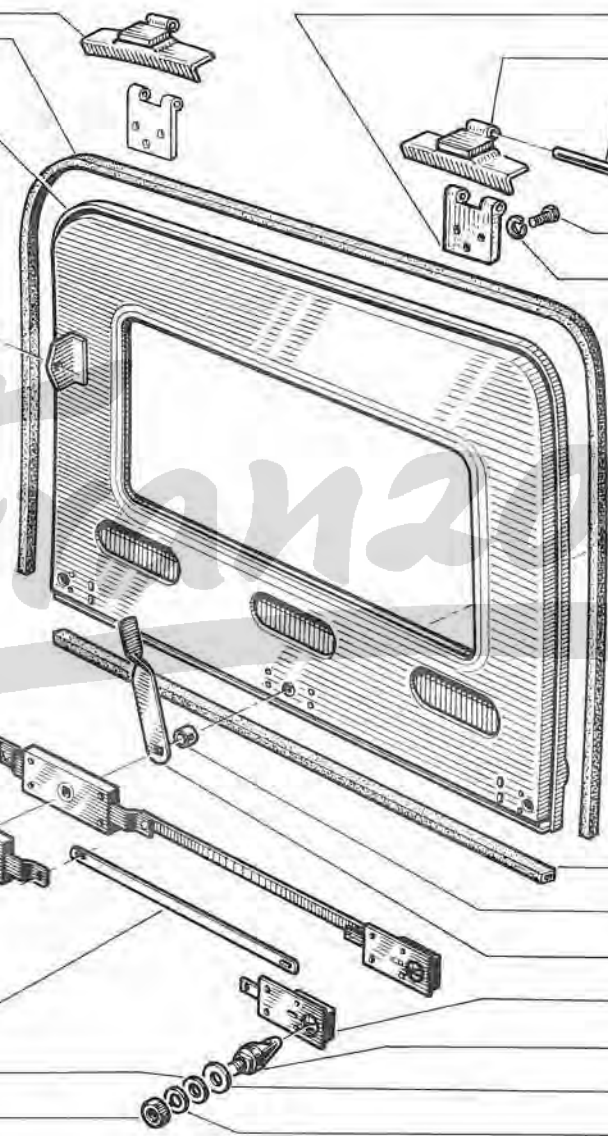

- 05 55 897 100
- 08 33 050 300
- 06 05 374 702
- 08 52 939 600
- 77 03 001 120
- 1081 200 646
- [08 51 478 600
- [08 51 478 652 & (1)
- 08 52 860 300
- [08 53 828 700
- [08 53 828 752 & (1)
- 8061 050 152
- 09 92 409 400
- 05 55 324 100
- 06 06 417 200
- 05 55 549 600
- [0854 380 600 (a)
- [7701 000 441 (b)
- 08 52 801 500
- 06 06 917 300
- 10 81 201 062

(a) VEH n° 1 ⇨ VEH n° 9743

(b) VEH n° 9744 ⇨ VEH n° ...

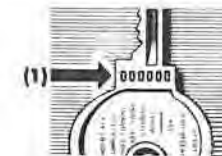



82.25

B P.R. 810



82.25

B P.R. 810

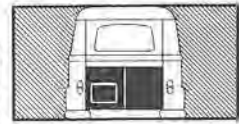

(▶◀ 2900) 06 60 432 700

05 54 963 900

08 54 367 000

08 21 473 600

06 06 360 800

10 98 342 132

(▶◀ 2900) 06 60 432 700

06 03 281 900

10 81 300 452

80 23 040 102

08 52 737 900

10 81 300 452

80 23 040 102

08 52 670 900

06 06 932 900

08 23 736 900

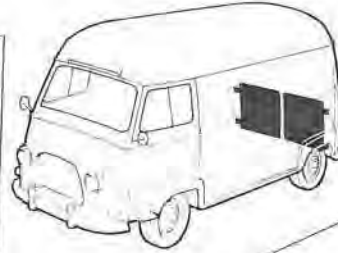

06 06 899 200

06 06 899 100

06 05 987 600

06 05 374 702

80 61 060 202

06 06 000 300

{ 08 20 330 900 (a)

08 21 443 900

05 55 799 700

06 05 925 300

{ 08 54 026 602 (b)

08 54 547 802 (c)

{ 05 55 380 600 (c)

77 00 512 603

05 54 685 600

(a)	R 2134	10/20/100/200
	R 2135	102 - VEH n° 9047 ⇔ VEH n° . . .
(b)	R 2134	10/20/21/22/24/26/27/28/29/30/40/41/42/100/140/200
	R 2135	201/202/203/204/207/211/220/230/231/240/241/242
(c)	R 2134	11/12/13/14/15/18/70/80/81/84/86/88/89/101/102/103
	R 2135	120/121/122/130/700/800/801/803/807/810/811



82.30

A P.R. 810

R 2134  

82.30

A P.R. 810

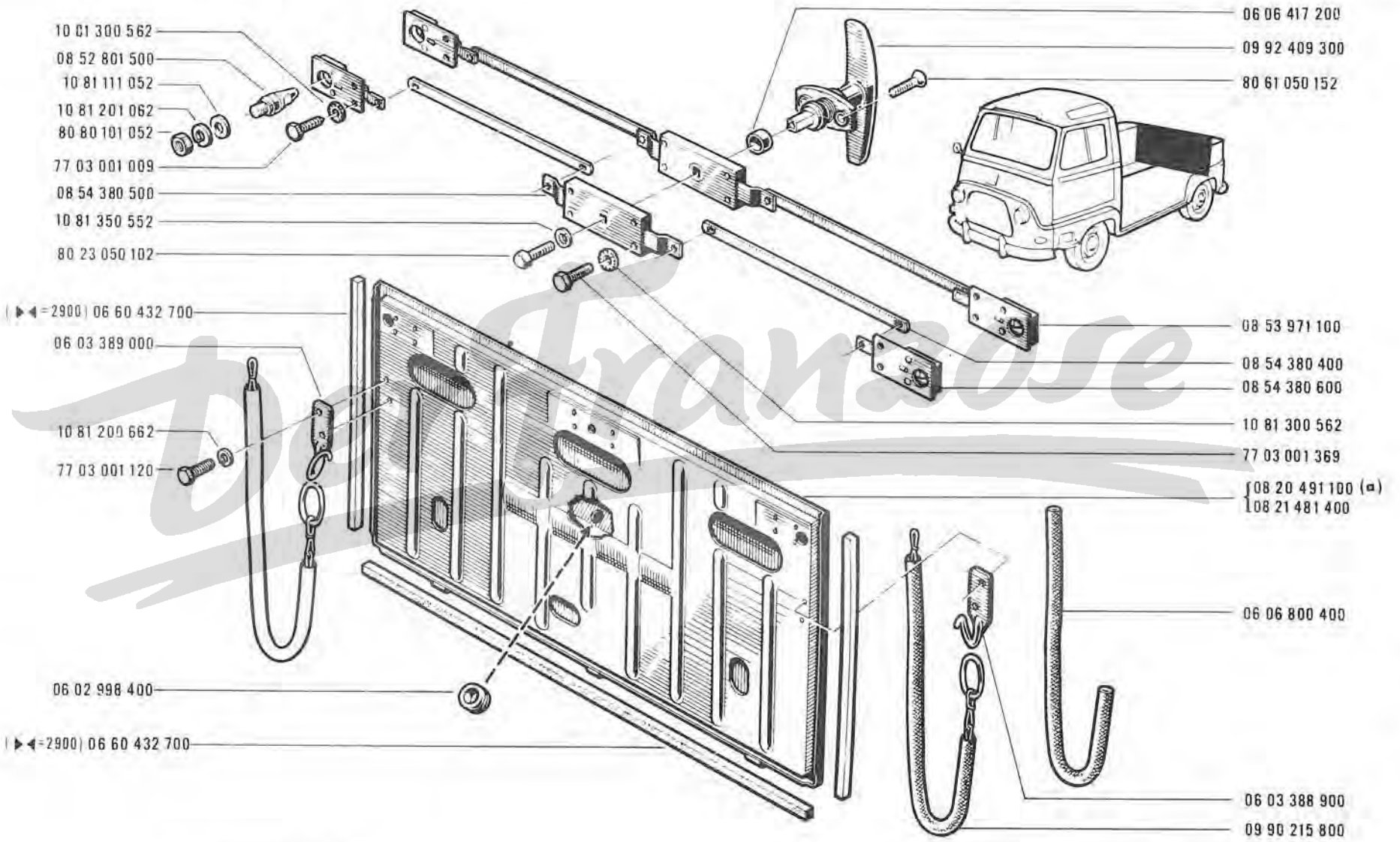
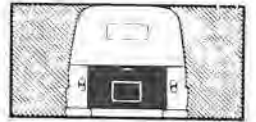

(a) R 2134 /100/102/200

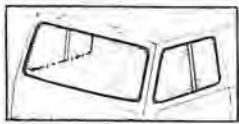

82.40

B P.R. 810

82.40

B P.R. 810

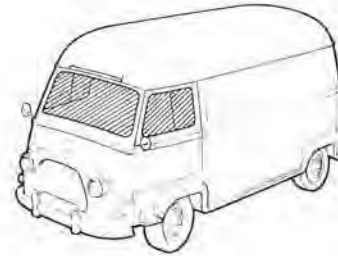

† 08 20 365 000
 77 00 506 031
 06 07 308 200
 08 52 819 600
 80 72 060 202
 08 52 819 500

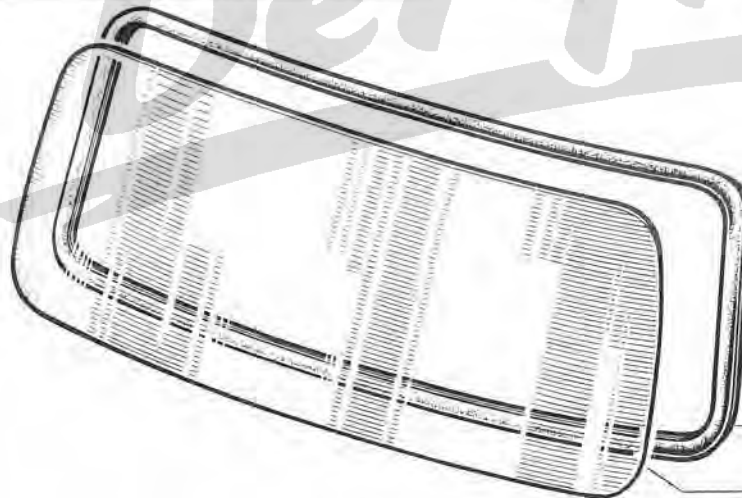
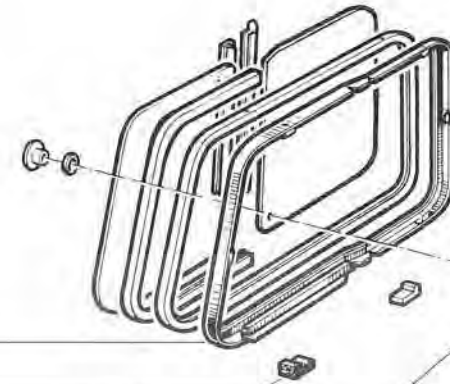

{ 08 20 364 900 †
 77 00 506 030
 { 8527856 (b)
 8527440
 { 8527581 (2) } (b)
 8528014 (4)
 8527580 (2)
 8528013 (4)
 6064525
 6071193
 6078052
 { 6068754 (b)
 6064526
 { 8527588 (2) } (b)
 8528012 (4)
 8527587 (2)
 8528011 (4)
 { 6064529 (b)
 6064528
 10 98 328 162
 6073082
 5555622
 { 8527269 (1) } (a)
 8528288 (4)
 8529245 (3)

(a) R 2134, R 2135 /41/86/240/803
 (b) R 2134, R 2135 /41/240

(1) TRIPLEX
 (2) SECURIT
 (3) LUXRIT BS
 (4) SPLINTEX



82.50

B P.R. 810

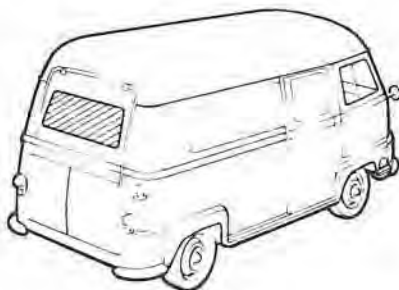

82.50

B P.R. 810



(a) 5559002 }
5558970 }

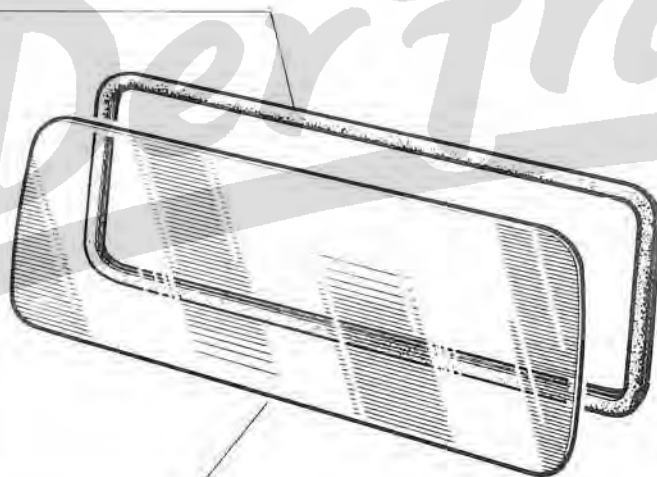

(a) { (1) 8529526 }
{ (2) 8529527 }
{ (1) 8529500 }
{ (2) 8529501 }

(a) R 2134, R 2135 / 41 / 240

(1) SECURIT

(2) SPLINTEX



8528126 (d) (1)
8528125 (c) (2)

5552990 (d)
5549796 (c)

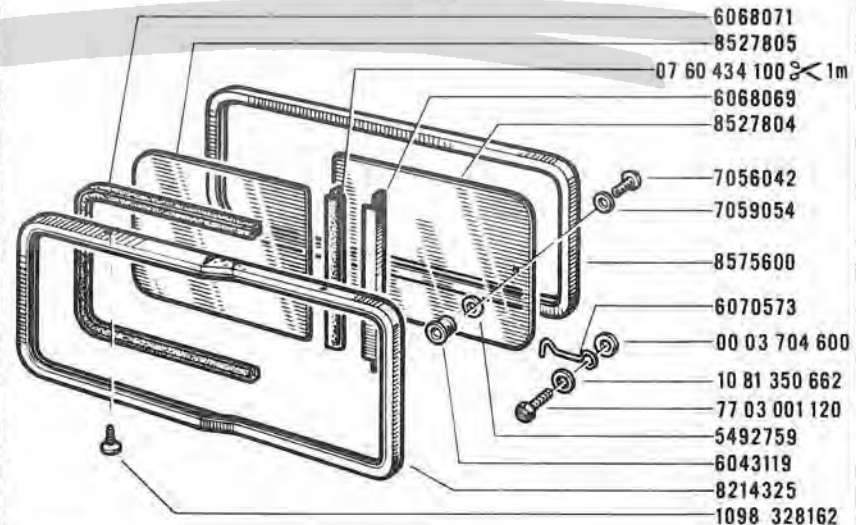

6068071
8527805
07 60 434 100 < 1m
6068069
8527804
7056042
7059054
8575600
6070573
00 03 704 600
10 81 350 662
77 03 001 120
5492759
6043119
8214325
1098 328162

(b)

(b) R 2134 / 200 / 201 / 202 / 203 / 204 / 207 / 211 / 220 / 800 / 801 / 803 / 807 / 810 / 811

(c) R 2134 / 100 / 101 / 102 / 103 / 120 / 121 / 122 / 130 / 140 / 230 / 231 / 241 / 242 / 700

(d) R 2134 / 240



82.55
B P.R. 810

82.55
B P.R. 810

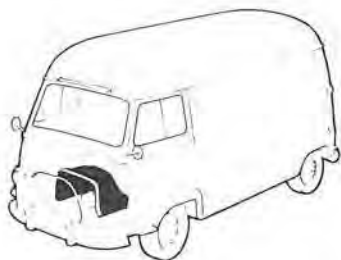

80 72 060 152

08 54 309 900

Der Franzose

02 56 210 200

06 06 538 000

10 81 300 652

80 80 100 642



84.01

A P.R. 810

84.01

A P.R. 810

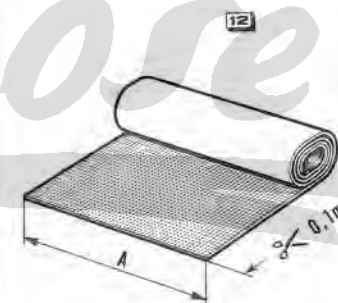
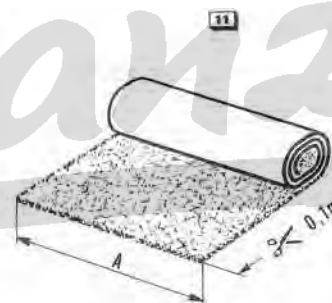
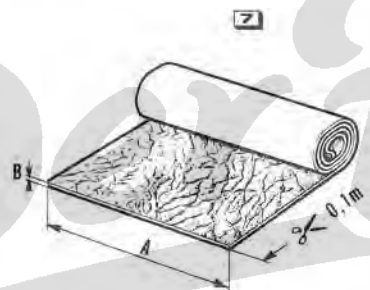
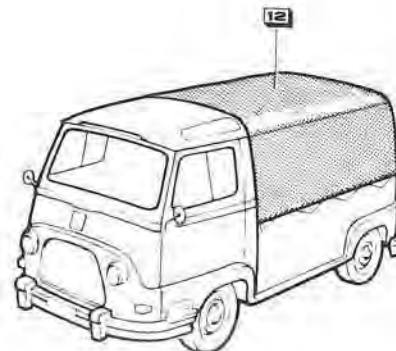

47 54 634 067 (B=1,5) }
47 54 734 235 (B=2) } (A=1400) 100

47 54 534 132 (B=0,4) (a) }
47 54 634 066 (B=1,5) } (A=1400) 100
47 54 734 234 (B=2) }

47 54 534 140 (A=1500) (B=0,4) }
47 54 634 400 (A=1400) (B=0,7) } (b) 100
47 54 734 351 (A=1440) (B=1,2) }

47 54 534 401 (A=1500) (B=0,4) }
47 54 634 397 (A=1400) (B=0,7) } (b) 100
47 54 734 388 (A=1440) (B=1,2) }

48 47 011 478 (A=1800)

47 57 721 994 † } (A=1400)
47 57 711 994 }

(a) VEH n° 1 ⇔ VEH n° 13001

(b) VEH n° 13002 ⇔ VEH n° ...



84.02

B P.R. 810

84.02

B P.R. 810

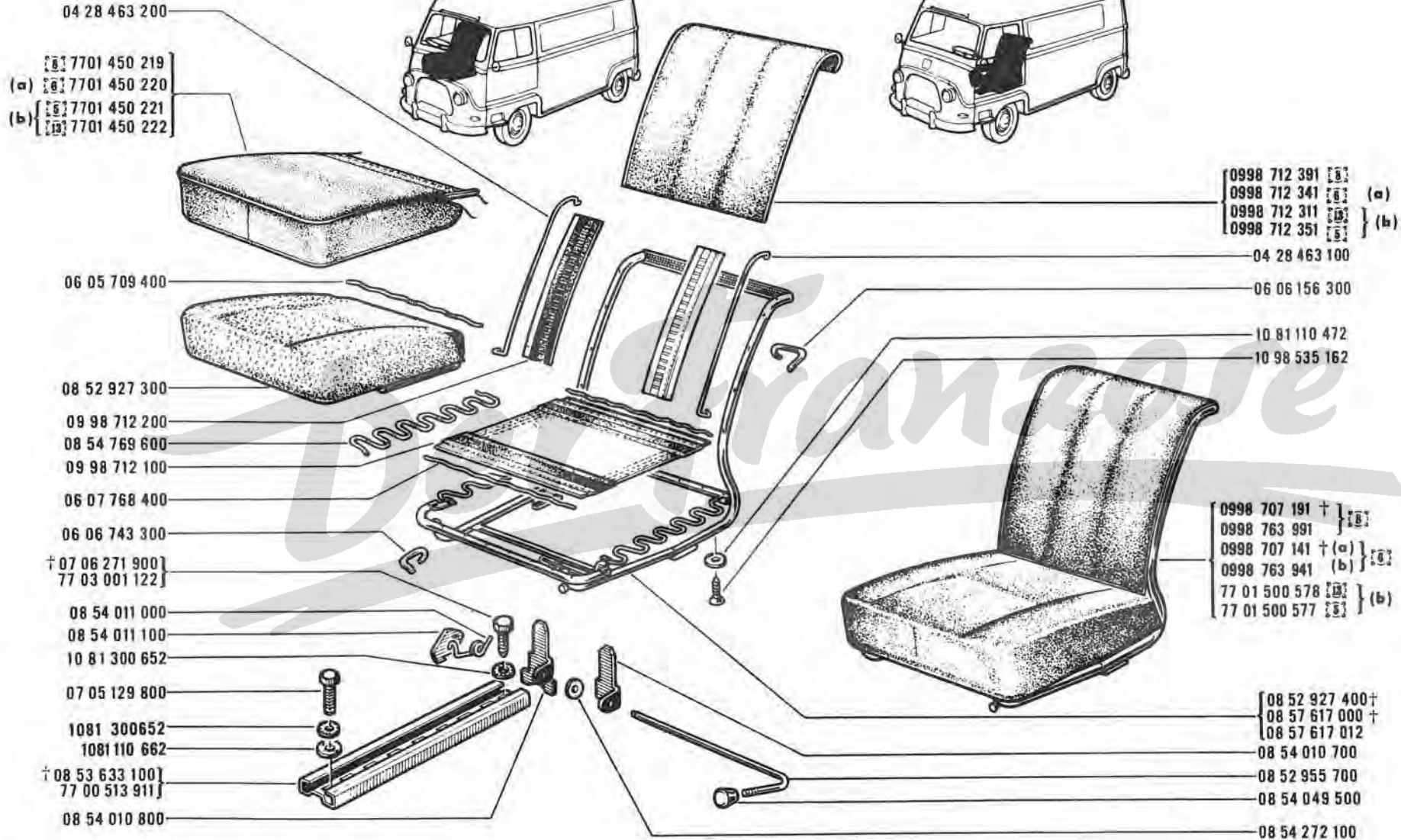

(a) VEH n° 1 ⇨ VEH n° 13001

(b) VEH n° 13002 ⇨ VEH n° ...



84.05

B P.R. 810



84.05

B P.R. 810



- (a) [8] 0998 632 841
- (b) { [8] 0998 632 811
- [8] 0998 632 851
- [8] 0998 632 892

- (a) [8] 0998 632 741
- (b) { [8] 0998 632 711
- [8] 0998 632 751
- [8] 0998 632 792

08 54 406 800

8080 310 852

1081 200 862

- [8] 08 57 531 200
- [8] 08 57 531 300

- 0998 743 941 [8] (a)
- 7701 500 584 [8] (b)
- 7701 500 583 [8] (b)
- 0998 743 991 [8]
- 0998 744 041 [8] (a)
- 7701 500 585 [8] (b)
- 7701 500 586 [8] (b)
- 0998 744 091 [8]

08 30 037 800

06 06 156 300

08 30 037 800

06 06 743 300

(a) VEH n° 13001

(b) VEH n° 13002 VEH n° ...



84.10

A P.R. 810



84.10

A P.R. 810



- | | | | | |
|--------------|------|-----|---|---|
| 0998 632 441 | [6] | (a) | } | ☞ |
| 7701 500 580 | [13] | (b) | | |
| 7701 500 579 | [5] | | | |
| 0998 632 492 | [8] | | | |
| 0998 639 941 | [6] | (a) | } | ☞ |
| 7701 500 582 | [13] | (b) | | |
| 7701 500 581 | [5] | | | |
| 0998 639 992 | [8] | | | |

- | | | | |
|-----|------|--------------|---|
| (a) | [6] | 0998 632 841 | } |
| (b) | [13] | 0998 632 811 | |
| | [5] | 0998 632 851 | |
| | [8] | 0998 632 892 | |

- | | | | |
|-----|------|--------------|---|
| (a) | [6] | 0998 632 741 | } |
| (b) | [13] | 0998 632 711 | |
| | [5] | 0998 632 751 | |
| | [8] | 0998 632 792 | |

08 54 406 800

8080 310 852

1081 200 862

- | | |
|---|---------------|
| ☞ | 08 52 784 600 |
| ☞ | 08 52 784 700 |

08 30 037 800

06 06 156 300

08 30 037 800

06 06 743 300

(a) VEH n° 1 ⇨ VEH n° 13001

(b) VEH n° 13002 ⇨ VEH n° . . .



84.30

B P.R. 810

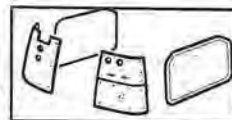

84.30

B P.R. 810

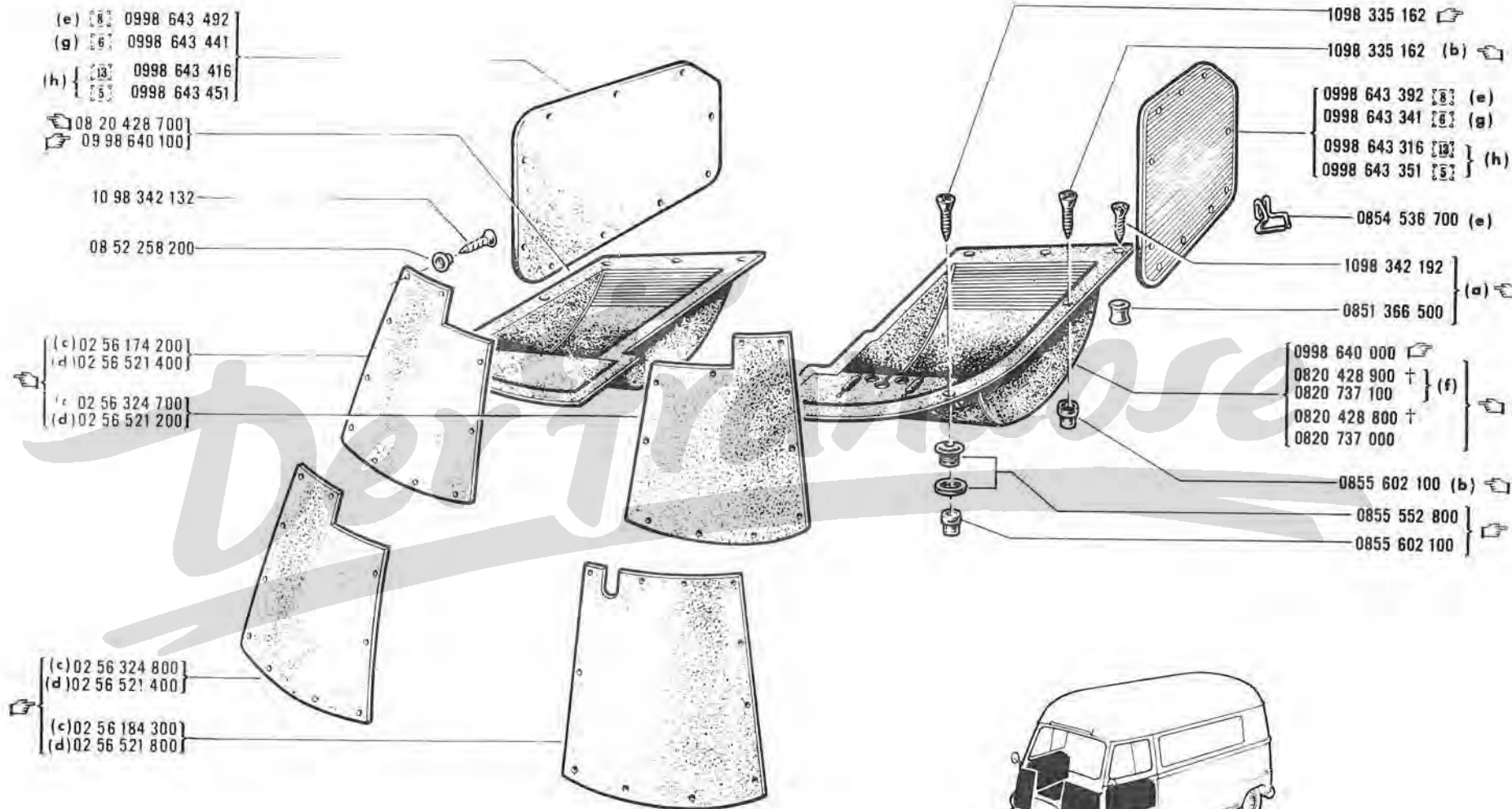

(a) VEH n°	1	⇨	VEH n°	1990
(b) VEH n°	1991	⇨	VEH n°	...
(c) VEH n°	1	⇨	VEH n°	6364
(d) VEH n°	6365	⇨	VEH n°	...

(e) R 2134, R 2135 /15/30/40/41/42/122/140/240/241/242				
(f) R 2134, R 2135 /41/240				
(g) R 2134, R 2135 /15/30/40/41/42/122/140/240/241/242 VEH n°	1	⇨	VEH n°	13001
(h) R 2134, R 2135 /122/140/240/241/242 VEH n°	13002	⇨	VEH n°	...



85.01
B P.R. 810



85.01
B P.R. 810

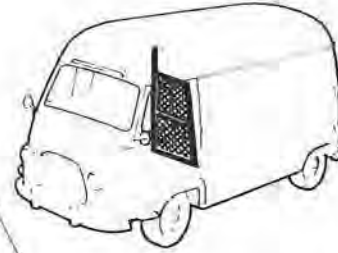
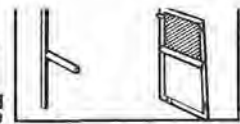

77 03 001 167
(d) { †06 07 215 200 }
06 07 475 500
80 80 100 852
10 81 200 842
(d) 08 30 059 300

(b) { (c) †08 22 926 300 }
(d) { (36) †08 32 113 400 }
77 00 504 361
(c) †08 22 926 500
(36) (d) 08 32 114 100

8080 100 852
1081 200 842
77 03 001 167

77 03 001 129

1081 350652

8080 100 652

06 05 313 500

08 21 644 700

1081 350652

77 03 001 118

(a)	R 2134, R 2135	/13/14/102/121
(b)	R 2134	10/11/12/15/18/20/21/22/24/26/27/28/29/30/40
	R 2135	41/42/100/101/103/120/122/130/140/200/201/202
(c)	VEH n°	1 ⇨ VEH n° 12741
	VEH n° 12742	⇨ VEH n° ...

VEH n°	1	⇨ VEH n° 12741
(36)		0830 059 300 -1-
		06 07 475 500 -1-



85.20

B P.R. 810

85.20

B P.R. 810

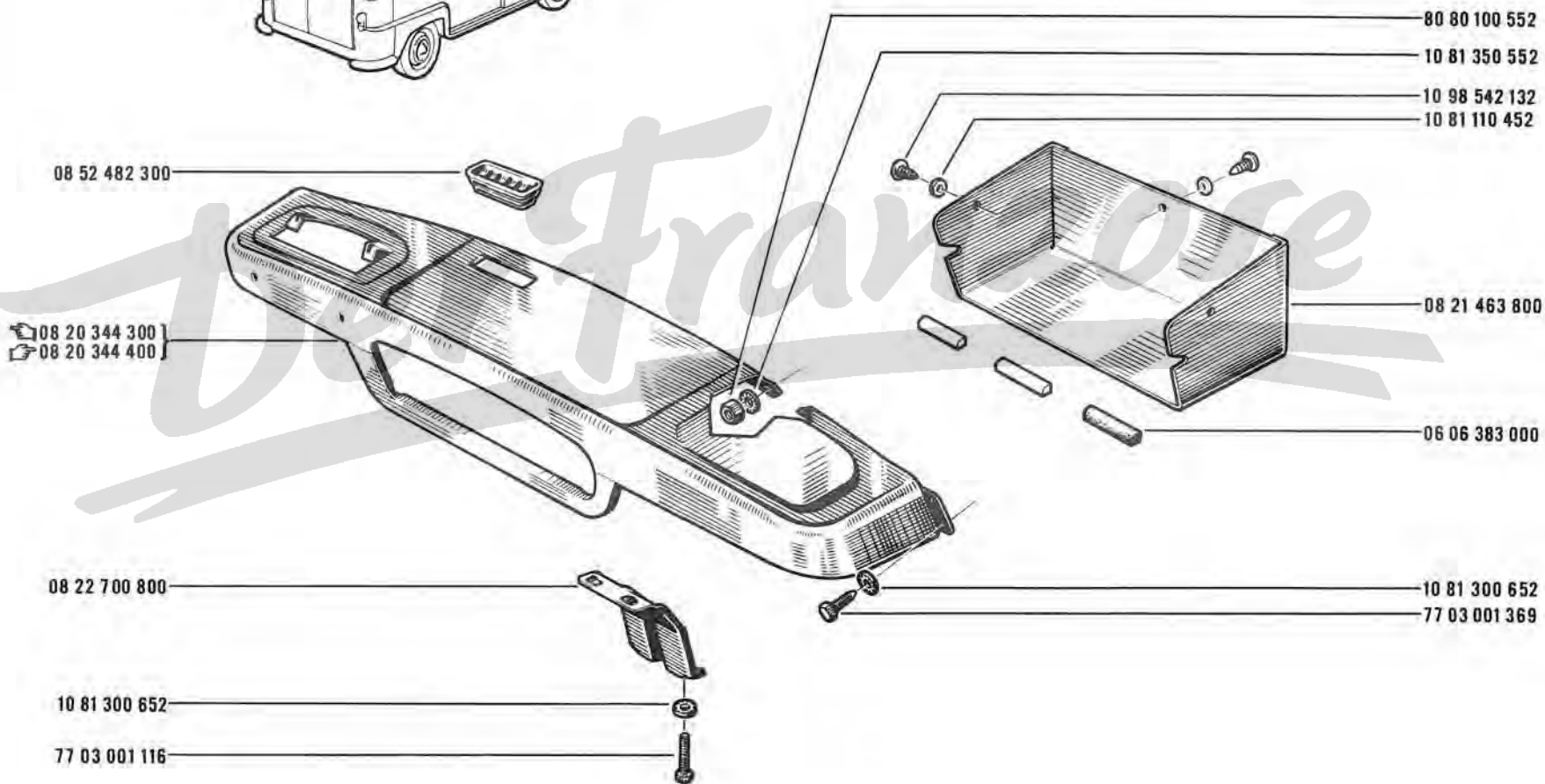
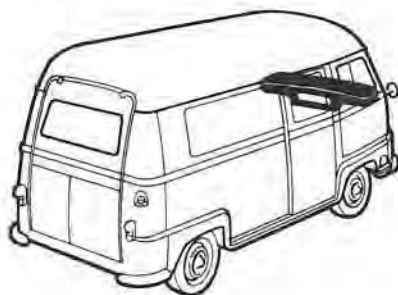



85.40

B P.R. 810

85.40

B P.R. 810

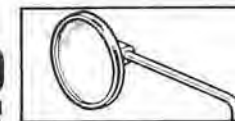

(a) 08 54 886 600
(b) 08 54 264 400

(a) 08 54 886 500
(b) 08 54 707 500



08 54 707 400

08 54 264 300

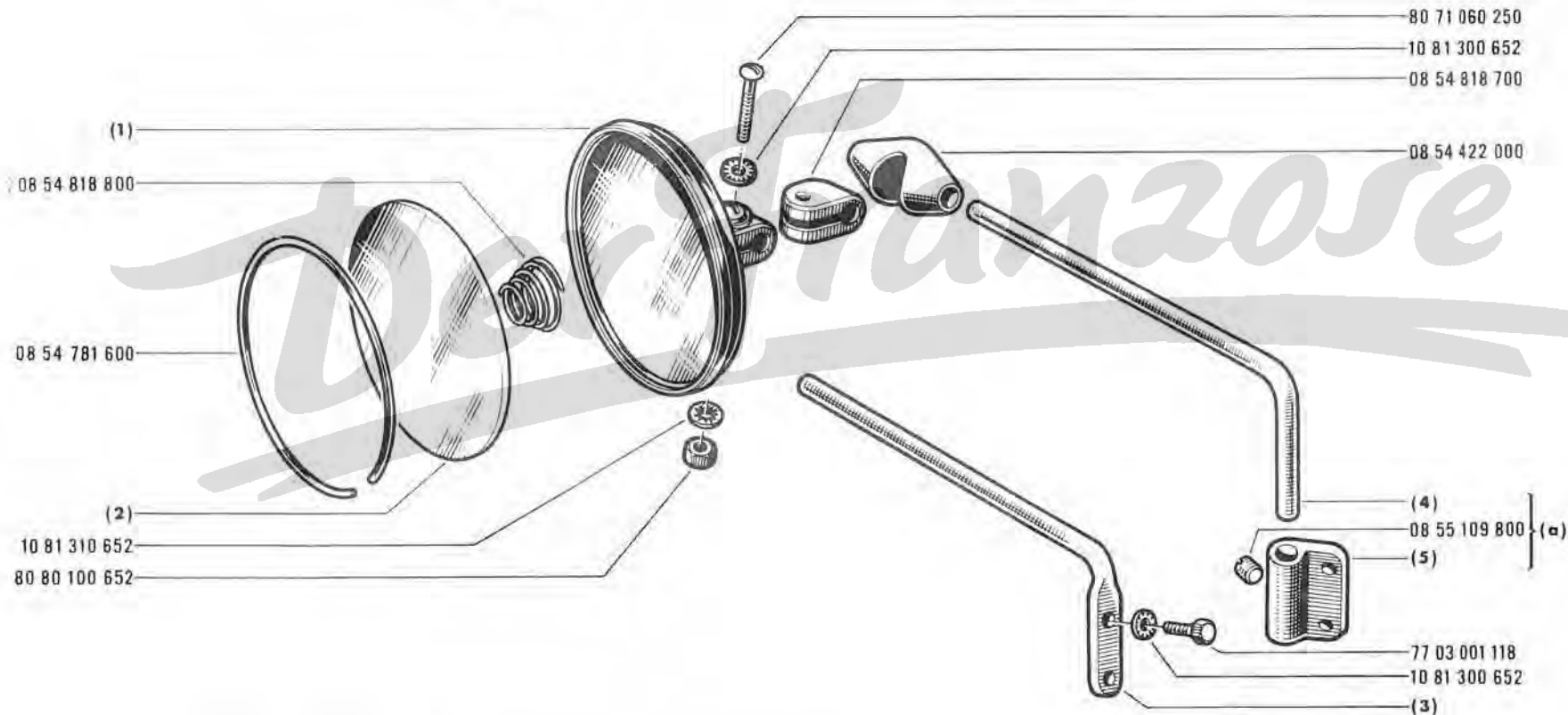

	8542643	8542644	8547074	8547075	8548865	8548866
(1)	8543443	8543443	8547814	8547814	8543443	8543443
(2)	8543444	8543444	8547815	8547815	8543444	8543444
(3)	8542647	8542646	8542646	8542647		
(4)					8551099	8551099
(5)					8551100	8551101

(a)	R 2134, R 2135	/12/14/18/120/121/130
	R 2134	/10/11/13/15/20/21/22/24/26/27/28/29/30/40
(b)	R 2135	/41/42/100/101/102/103/122/140/200/201/202 203/204/207/211/220/230/231/240/241/242



85.45
B F.R. 810



85.45
B P.R. 810

R 2135 { +08 52 894 300 }
08 55 765 200



08 54 302 900

R 2134 { +08 57 576 200 }
08 55 765 100



07 06 263 300



08 52 816 300

08 52 807 800

(a) +06 07 042 400

(b) 08 55 914 600



08 55 548 400

08 52 661 100

08 52 923 200

08 52 661 100

08 55 266 500

08 54 302 900 (a)

08 54 302 900

06 03 756 100

06 07 113 900

(a)	VEH n°	1	⇨	VEH n°	8873
(b)	VEH n°	8874	⇨	VEH n°	...



85.50
B P.R. 810

85.50
B P.R. 810



08 53 523 300

10 98 342 192

{ 08 52 754 500 †
77 00 510 599

77 03 001 005
10 81 300 452
10 81 110 472
08 21 332 000
08 21 339 900
06 05 520 600
06 06 251 400
08 55 509 400

05 54 736 713
10 81 300 652
77 03 001 120

Derfranzose





85.55
A P.R. 810

R 2134 / 11/30/40/41/42/101/103/140/240/241/242
R 2135

85.55
A P.R. 810

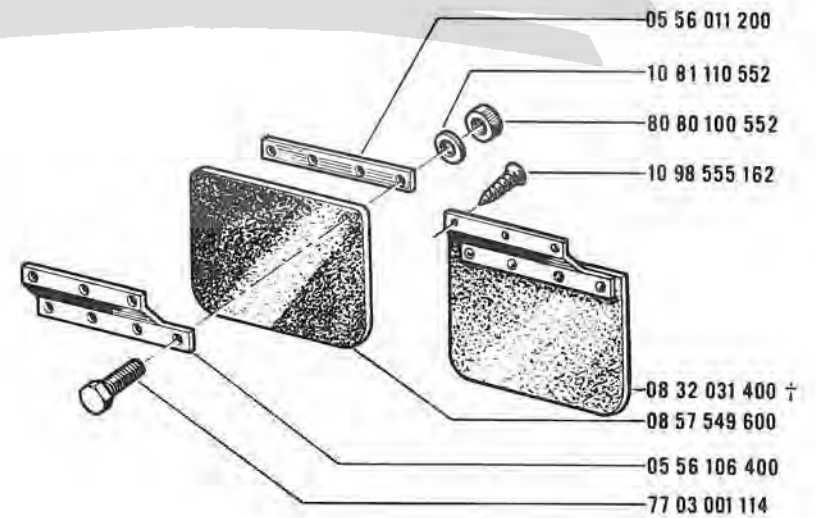
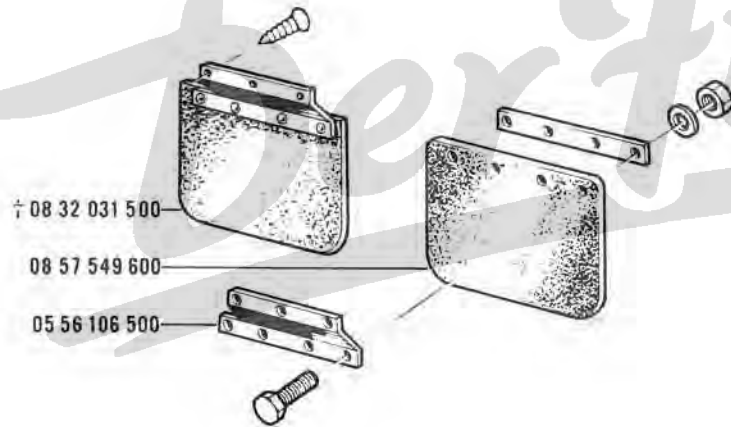
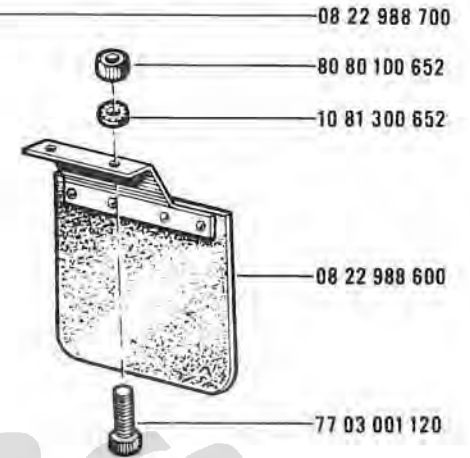
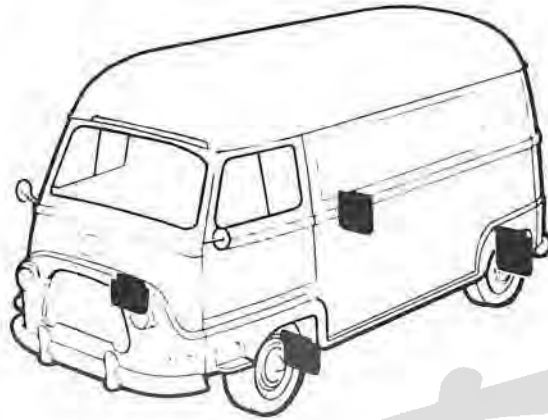

Der Franzose

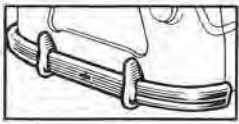

85.80

B P.R. 810

85.80

B P.R. 810

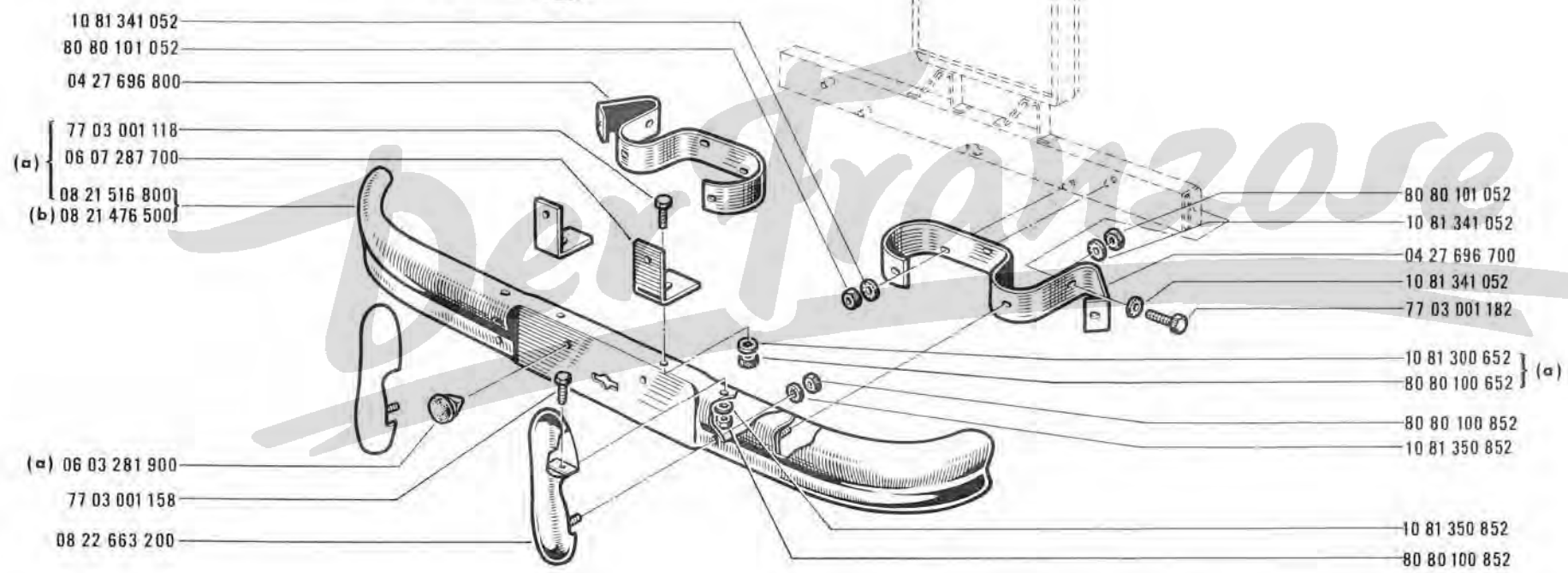
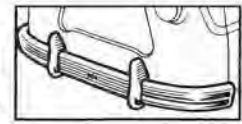

(a)	R 2134	11/12/13/14/15/18/21/22/24/26/27/28/29/30/40/41/42/70/80/81/84/86
	R 2135	88/89/101/102/103/120/121/122/130/140/201/202/203/204/207/211/220
(b)	R 2134, R 2135	230/231/240/241/242/700/800/801/803/807/810/811
		10/20/100/200



85.85

B P.R. 810

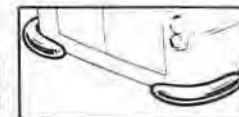

85.85

B P.R. 810



80 80 100 852

10 81 340 852

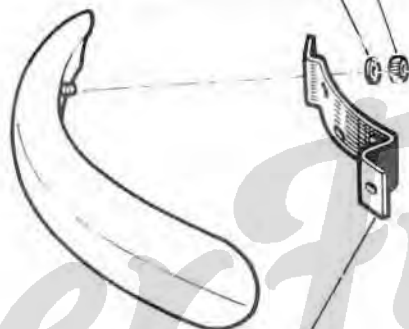

04 27 692 700

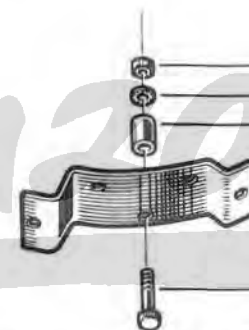

80 80 101 052

10 81 341 052

06 06 018 500

04 27 692 800

77 03 001 190



{ 08 22 604 900 †
08 22 604 902

Der Franzose

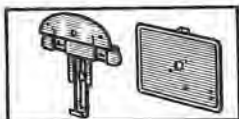

85.90

B P.R. 810

85.90

B P.R. 810



(a)

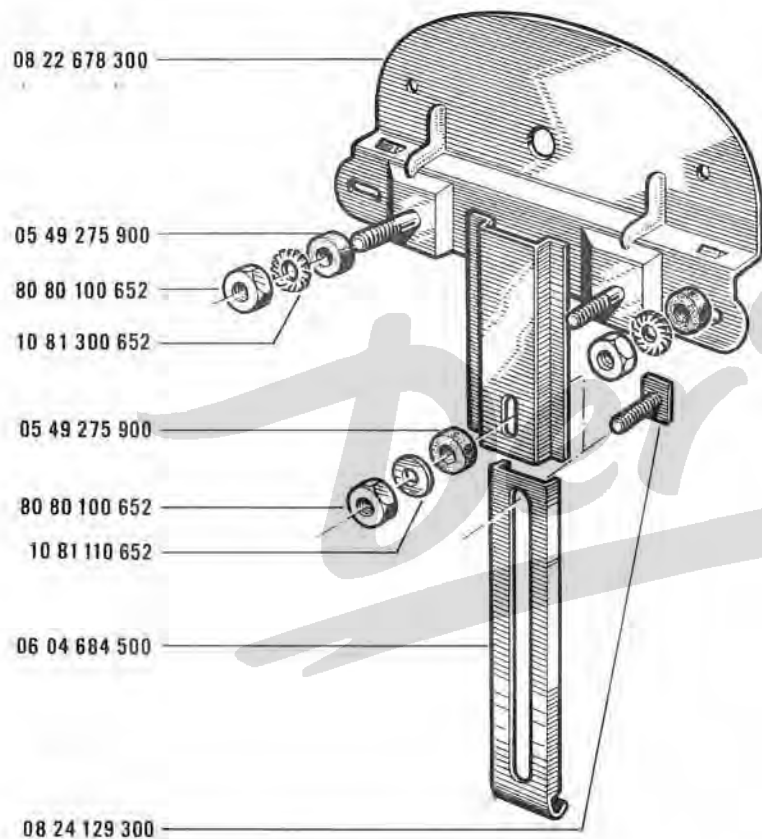

(b)

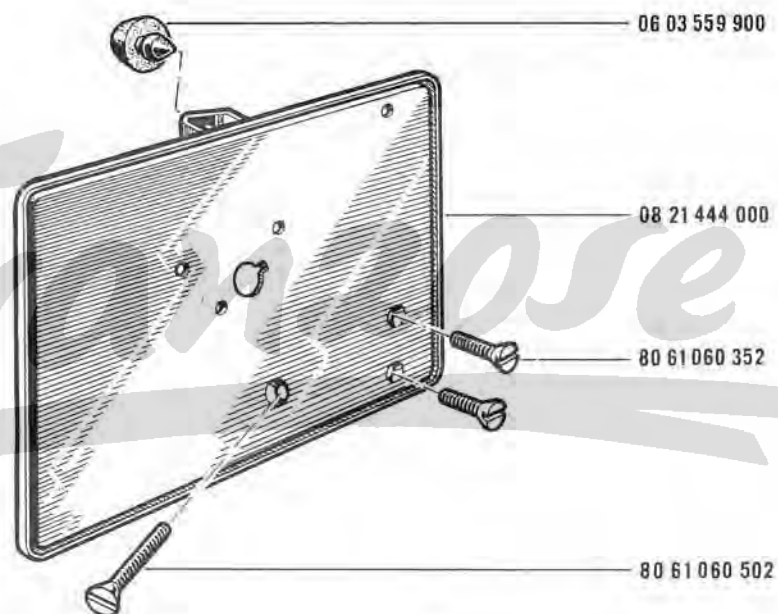

(a)	R 2134	11/12/13/14/15/18/21/22/24/26/27/28/29/30/40
	R 2135	41/42/70/80/81/84/86/88/89/101/103/120/121
		122/130/140/201/202/203/204/207/211/220/230
		231/240/241/242/700/800/801/803/807/810/811
	102 VEH n°	1 ⇨ VEH n° 9046

(b) R.2134/100/200



89.01

B P.R. 810

89.01

B P.R. 810

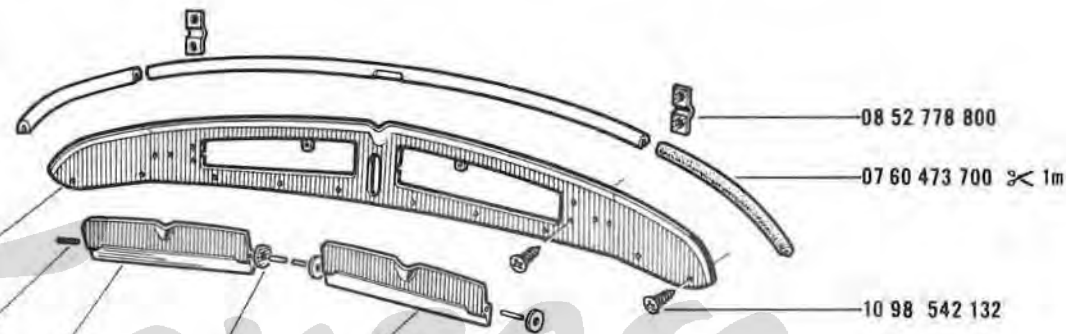

† 08 21 411 100]
77 00 505 997]

08 55 132 700

04 27 969 500

06 07 203 300

04 27 969 600

08 52 778 800

07 60 473 700 < 1m

10 98 542 132

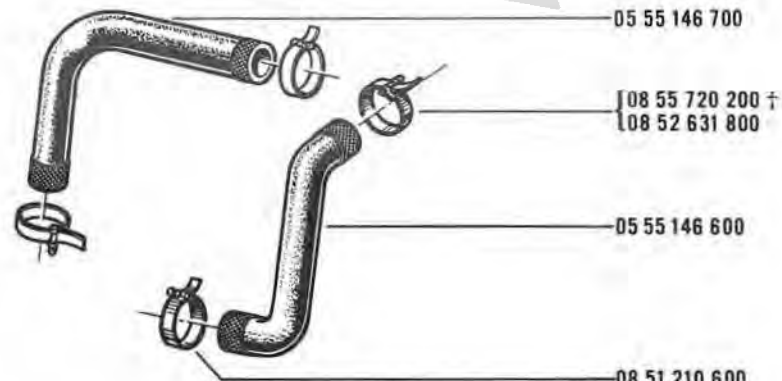
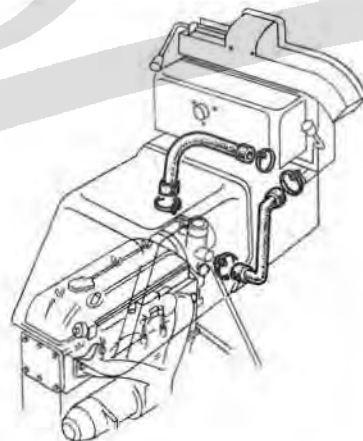

05 55 146 700

[08 55 720 200 †
08 52 631 800

05 55 146 600

08 51 210 600

Der Franzone



100.01

100.01



1



2

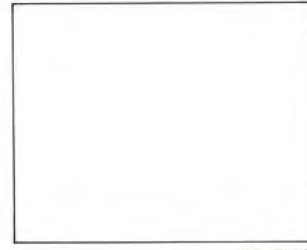

3



4

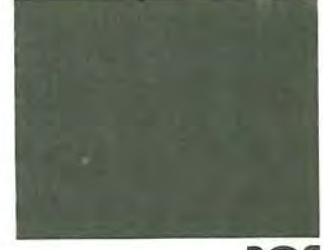

5



6



7



8

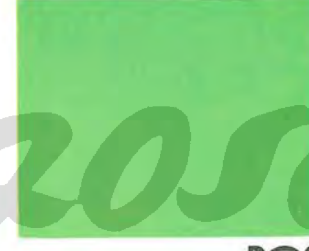

9



10



11



12



13



14



15



16



17



18



19



20

Der Franze

1 Numéro des pièces - Delnumre - Ersatzteilnummer - Part Number - Numeros de las piezas - Numero del pezzo - Nummers der onderdelen - Reservedelsnummer

2 Numéro des planches - Planche-Numre - Bildtafelnummer - Plate Number - Numeros de las laminas - Numero della tavola - Nummers der afbeeldingen - Bildnummer

3 Quantité par véhicule - Antal pr. vogn - Menge pro fahrz - Quantity per vehicle - Cantidad por vehículo - Quantita per veicolo - Aant. per wagen - Antal per bil

			1			2			3			1			2			3											
00	01	713	800	1430	01	02	56	521	400	8430	01	03	54	161	100	8135	01	04	27	816	000	8120	01	04	28	571	100	8146	01
00	03	704	600	8250	02	02	56	521	800	8430	01	03	54	257	500	8105	01	04	27	840	700	8117	02	04	28	571	200	8146	01
00	72	572	100	7001	02	03	53	600	800	8167	01	03	54	257	500	8110	01	04	27	840	700	8120	02	04	28	571	300	8145	02
00	75	120	400	5801	01	03	53	600	800	8177	01	03	54	258	800	8146	01	04	27	913	600	4010	01	04	28	589	300	8130	02
00	75	120	400	5803	01	03	53	601	700	8145	01	03	54	323	511	8117	01	04	27	969	500	8901	01	04	28	589	400	8130	02
02	54	608	400	4235	02	03	53	634	300	8167	01	04	25	111	700	4201	02	04	27	969	600	8901	01	04	28	624	700	4301	02
02	55	587	700	8130	01	03	53	634	300	8175	01	04	25	293	300	1860	04	04	27	981	500	8140	01	04	28	625	000	4301	02
02	55	587	700	8136	01	03	53	634	300	8177	01	04	25	344	300	1833	01	04	28	046	700	8135	01	04	28	625	100	4201	02
02	55	587	700	8138	01	03	53	643	000	8130	01	04	27	430	100	5101	02	04	28	065	100	5101	02	04	28	629	500	4210	02
02	55	587	800	8130	01	03	53	643	100	8130	01	04	27	521	900	3120	02	04	28	105	200	4010	01	04	28	630	800	3130	01
02	55	587	800	8136	01	03	53	676	100	8117	01	04	27	522	000	3120	02	04	28	112	200	8167	01	04	28	633	500	5101	02
02	55	587	800	8138	01	03	53	676	200	8120	01	04	27	641	500	8145	03	04	28	112	200	8175	01	04	28	636	200	3140	01
02	56	012	300	8167	01	03	53	715	900	8117	01	04	27	641	600	8145	02	04	28	112	200	8177	01	04	28	636	300	3140	01
02	56	012	300	8170	01	03	53	715	900	8120	01	04	27	682	500	8167	01	04	28	117	200	8140	01	04	28	738	200	4301	02
02	56	012	400	8167	01	03	53	730	100	8105	01	04	27	685	400	8145	06	04	28	209	000	7001	01	04	28	738	300	4210	02
02	56	012	400	8170	01	03	53	730	100	8110	01	04	27	686	300	4401	12	04	28	225	200	3130	01	04	28	765	400	3150	01
02	56	053	000	8120	01	03	53	730	200	8105	01	04	27	689	200	8105	01	04	28	225	700	3120	01	04	28	811	100	8175	02
02	56	118	800	8150	01	03	53	730	200	8110	01	04	27	692	700	8585	01	04	28	225	800	3120	01	04	28	811	300	8175	04
02	56	139	700	7001	01	03	53	730	300	8105	01	04	27	692	800	8585	01	04	28	233	200	3150	01	04	28	885	200	3120	02
02	56	174	200	8430	01	03	53	730	300	8110	01	04	27	696	700	8580	01	04	28	255	000	1430	01	04	28	908	000	8117	01
02	56	184	300	8430	01	03	53	747	800	5010	01	04	27	696	800	8580	01	04	28	259	300	3130	01	05	48	395	700	6138	01
02	56	201	900	4210	01	03	53	747	800	5020	01	04	27	698	700	8130	01	04	28	279	000	3120	01	05	48	395	700	7101	01
02	56	202	000	4210	01	03	53	796	200	8150	01	04	27	698	700	8135	01	04	28	295	400	8145	02	05	48	395	700	8175	01
02	56	210	200	8255	01	03	53	875	000	1510	01	04	27	710	100	8175	01	04	28	343	700	5010	01	05	48	395	700	8177	01
02	56	324	700	8430	01	03	53	906	300	8117	01	04	27	710	100	8177	01	04	28	343	700	5020	01	05	49	034	700	5805	01
02	56	324	800	8430	01	03	53	959	200	8120	01	04	27	739	100	8110	01	04	28	343	800	5010	01	05	49	275	900	8250	01
02	56	388	200	8150	01	03	54	085	100	8167	01	04	27	739	400	8145	01	04	28	343	800	5020	01	05	49	275	900	8590	03
02	56	394	900	8150	01	03	54	085	200	8167	01	04	27	739	400	8145	02	04	28	380	800	4020	01	05	52	539	500	1830	01
02	56	408	100	8167	01	03	54	085	300	8150	01	04	27	751	500	8105	01	04	28	398	900	4210	02	05	52	539	500	1833	02
02	56	408	200	8167	01	03	54	085	400	8150	01	04	27	751	500	8110	01	04	28	449	300	1501	01	05	52	658	900	4315	02
02	56	408	300	8150	01	03	54	085	500	8150	01	04	27	766	900	8130	01	04	28	463	100	8402	01	05	52	659	000	4235	02
02	56	408	400	8167	01	03	54	085	600	8150	01	04	27	766	900	8130	02	04	28	463	200	8402	01	05	52	659	000	4315	02
02	56	408	600	8130	01	03	54	085	800	8167	01	04	27	766	900	8135	01	04	28	496	400	3120	01	05	52	676	400	5830	04
02	56	408	700	8130	01	03	54	085	900	8167	01	04	27	766	900	8135	02	04	28	496	600	3120	01	05	53	195	900	8140	01
02	56	408	800	8130	02	03	54	114	800	8150	01	04	27	769	700	8140	01	04	28	568	200	8167	02	05	53	195	900	8175	01
02	56	408	900	8130	01	03	54	114	900	8150	01	04	27	786	400	8105	01	04	28	568	400	8130	01	05	53	195	900	8177	01
02	56	409	000	8130	01	03	54	115	000	8150	01	04	27	736	400	8110	01	04	28	568	500	8130	01	05	53	430	500	4010	01
02	56	409	200	8167	01	03	54	115	100	8150	01	04	27	791	600	8175	01	04	28	568	600	8167	02	05	53	539	900	5810	01
02	56	410	400	8146	01	03	54	117	400	8146	01	04	27	791	600	8177	01	04	28	570	900	8146	01	05	53	539	900	5815	01
02	56	521	200	8430	01	03	54	117	500	8146	01	04	27	816	000	8117	01	04	28	571	000	8146	01	05	53	637	900	4010	01

1 Numéro des pièces - Delnumre - Ersatzteilnummer - Part Number - Numeros de las piezas - Numero del pezzo - Nummers der onderdelen - Reservedelsnummer

2 Numéro des planches - Planche-Numre - Bildtafelnummer - Plate Number - Numeros de las laminas - Numero della tavola - Nummers der afbeeldingen - Bildnummer

3 Quantité par véhicule - Antal pr. vogn - Menge pro fahrzg - Quantity per vehicle - Cantidad por vehículo - Quantita per veicolo - Aant. per wagen - Antal per bil

			1			2			3			1			2			3																																																																																																																																																																																																																																																																																																																																																																																													
05 54 087 600 8125	01	05 55 165 600 8125	02	05 55 486 224 1510	04	05 55 845 100 1430	01	06 03 388 500 8205	01	05 54 402 204 8205	02	05 55 170 400 8205	02	05 55 491 300 3150	01	05 55 897 000 8250	01	06 03 388 500 8210	01	05 54 402 204 8210	02	05 55 170 400 8210	02	05 55 491 400 3113	01	05 55 897 100 8221	02	06 03 388 600 8205	01	05 54 499 000 5810	01	05 55 192 800 8152	04	05 55 491 800 3113	01	05 55 898 800 8221	01	06 03 388 600 8210	01	05 54 617 100 3120	02	05 55 207 500 8140	02	05 55 493 100 5101	02	05 55 900 200 8250	01	06 03 388 900 8230	01	05 54 671 500 8146	04	05 55 254 100 6142	01	05 55 497 400 1501	01	05 56 011 200 8555	02	06 03 389 000 8230	01	05 54 685 600 8225	02	05 55 264 100 4301	02	05 55 502 400 3130	01	05 56 047 800 3140	02	06 03 400 600 6240	01	05 54 689 700 4201	02	05 55 270 200 8105	01	05 55 506 100 6243	XX	05 56 049 500 3140	01	06 03 437 000 6246	01	05 54 711 700 3120	02	05 55 270 200 8110	01	05 55 506 900 6243	XX	05 56 049 600 3140	01	06 03 450 100 3130	01	05 54 720 900 5201	02	05 55 274 100 8205	02	05 55 507 000 6243	01	05 56 064 800 8135	01	06 03 450 100 3130	01	05 54 736 713 8550	02	05 55 274 100 8210	02	05 55 518 300 1430	01	05 56 064 900 8135	01	06 03 518 300 6240	06	05 54 739 000 8145	01	05 55 274 200 8205	02	05 55 540 600 5825	01	05 56 065 000 8135	02	06 03 532 400 5830	12	05 54 741 500 4401	12	05 55 274 200 8210	02	05 55 542 600 3140	01	05 56 106 400 8555	02	06 03 540 500 6246	01	05 54 741 502 4401	12	05 55 292 800 1430	01	05 55 542 700 3140	01	05 56 106 500 8555	01	06 03 559 900 8590	01	05 54 744 100 8167	02	05 55 292 800 1430	02	05 55 542 900 1510	04	05 56 158 800 5805	01	06 03 690 800 6243	XX	05 54 744 100 8175	01	05 55 299 000 8250	01	05 55 544 300 8105	01	05 56 181 900 8135	01	06 03 756 100 8545	02	05 54 744 100 8177	01	05 55 320 400 8167	01	05 55 544 300 8110	01	05 56 182 000 8135	01	06 03 871 100 6240	02	05 54 766 600 5830	01	05 55 324 100 8221	01	05 55 544 700 3113	01	05 56 200 200 4201	02	06 03 900 300 4301	02	05 54 822 000 7301	01	05 55 380 600 8225	02	05 55 544 702 3113	01	05 56 255 200 3120	01	06 03 911 700 7001	01	05 54 862 100 4201	01	05 55 405 100 5805	01	05 55 544 800 3113	01	05 56 263 000 8145	02	06 03 917 600 6138	01	05 54 862 200 4201	01	05 55 420 900 8167	01	05 55 544 802 3113	01	05 56 276 800 5830	01	06 03 936 600 4235	01	05 54 912 100 8140	01	05 55 421 000 7001	02	05 55 549 000 8130	01	05 56 350 300 5801	01	06 03 936 600 4235	02	05 54 916 400 8130	01	05 55 429 900 4401	12	05 55 549 600 8221	01	05 56 418 200 3120	02	06 03 936 600 4315	01	05 54 916 400 8136	01	05 55 434 900 4030	01	05 55 562 200 8240	01	06 00 353 723 5803	01	06 04 194 800 4235	02	05 54 916 400 8138	01	05 55 435 000 4030	01	05 55 568 700 1510	04	06 02 322 500 1430	01	06 04 194 800 4315	02	05 54 957 200 4010	01	05 55 437 800 6243	XX	05 55 627 400 1575	01	06 02 322 500 1430	02	06 04 221 000 4301	02	05 54 963 900 8225	01	05 55 466 300 7310	01	05 55 657 900 4201	02	06 02 322 500 1430	10	06 04 227 200 1501	06	05 54 964 000 4010	01	05 55 482 400 1440	01	05 55 657 900 4301	02	06 02 349 600 1920	02	06 04 270 600 5810	01	05 54 979 600 8250	01	05 55 483 600 3120	01	05 55 658 000 4201	02	06 02 938 200 8175	01	06 04 270 600 5815	01	05 54 985 200 8146	02	05 55 485 000 1701	01	05 55 658 000 4301	02	06 02 982 900 1510	01	06 04 305 800 5801	02	05 55 020 400 8215	01	05 55 485 100 1701	01	05 55 687 400 7310	01	06 02 989 600 6240	01	06 04 305 800 5803	02	05 55 072 800 8180	01	05 55 485 200 1701	01	05 55 698 500 6118	01	06 02 998 400 6246	03	06 04 311 900 8250	01	05 55 072 800 8150	01	05 55 485 400 1510	04	05 55 703 600 4210	06	06 02 998 400 8230	01	06 04 319 900 3130	01	05 55 131 100 8150	01	05 55 485 500 1510	01	05 55 703 600 4301	06	06 03 186 800 5810	01	06 04 407 700 8215	02	05 55 131 200 8150	01	05 55 485 600 1880	01	05 55 736 900 8140	02	06 03 186 800 5815	01	06 04 446 400 4315	02	05 55 146 600 8901	01	05 55 485 700 1601	01	05 55 740 900 4201	02	06 03 281 900 8225	03	06 04 506 000 6243	XX	05 55 146 700 8901	01	05 55 485 800 1601	01	05 55 775 200 7801	01	06 03 281 900 8580	02	06 04 575 900 1440	01	05 55 151 104 8205	02	05 55 486 100 1510	04	05 55 709 700 8225	02	06 03 306 200 8205	02	06 04 665 502 8117	02	05 55 151 104 8210	02	05 55 486 124 1510	04	05 55 803 500 7001	01	06 03 306 200 8210	02	06 04 665 502 8120	02	05 55 151 104 8215	01	05 55 486 200 1510	04	05 55 844 900 1430	01	06 03 372 400 7801	01	06 04 684 500 8590	01

1 Numéro des pièces - Delnumre - Ersatzteilnummer - Part Number - Numeros de las piezas - Numero del pezzo - Nummers der onderdelen - Reservedelsnummer

2 Numéro des planches - Planche-Numre - Bildtafelnummer - Plate Number - Numeros de las laminas - Numero della tavola - Nummers der afbeeldingen - Bildnummer

3 Quantité par véhicule - Antal pr. vogn - Menge pro fahrzg - Quantity per vehicle - Cantidad por vehículo - Quantita per veicolo - Aant. per wagen - Antal per bil

				1			2			3			1			2			3																																																																																																																																																																																																																																																																																																																																																																																												
06 04 685 100 4010	01	06 05 550 000 8210	02	06 05 987 600 8225	01	06 06 202 100 8140	01	06 06 472 400 8105	01	06 04 743 100 3120	03	06 05 563 200 4210	02	06 05 991 400 4235	02	06 06 202 200 8140	01	06 06 472 400 8110	01	06 04 827 600 5803	01	06 05 563 300 4210	02	06 05 991 400 4315	02	06 06 225 100 3150	01	06 06 512 200 8215	02	06 04 844 700 7301	01	06 05 573 500 5805	01	06 05 994 902 5810	01	06 06 233 800 4201	08	06 06 512 900 5810	02	06 04 852 400 6142	02	06 05 573 700 5805	01	06 05 994 902 5815	01	06 06 238 600 4301	02	06 06 512 900 5815	02	06 04 514 500 5801	01	06 05 624 900 8140	02	06 05 995 302 8215	02	06 06 243 800 8125	02	06 06 519 200 5101	02	06 04 514 500 5803	01	06 05 627 100 6246	01	06 05 995 309 8215	02	06 06 251 400 6132	04	06 06 538 000 8255	01	06 04 585 500 5810	01	06 05 678 600 4301	02	06 05 995 400 8130	01	06 06 251 400 8550	04	06 06 551 400 1501	01	06 04 585 500 5815	01	06 05 681 100 4210	04	06 06 000 300 8225	02	06 06 267 400 8140	01	06 06 562 300 8205	02	06 05 217 800 3120	01	06 05 698 900 3150	01	06 06 003 900 7310	01	06 06 268 300 1440	08	06 06 562 300 8210	02	06 05 217 900 3120	01	06 05 709 400 8402	01	06 06 007 100 4020	02	06 06 273 800 4010	02	06 06 666 900 8205	01	06 05 238 400 7301	01	06 05 722 800 6246	01	06 06 007 200 7301	01	06 06 293 300 4220	02	06 06 666 900 8210	01	06 05 238 400 7310	01	06 05 722 800 6246	02	06 06 007 302 4020	01	06 06 293 300 4225	02	06 06 673 600 8125	02	06 05 254 800 8205	XX	06 05 722 800 6246	04	06 06 015 200 4010	03	06 06 294 100 6246	01	06 06 678 600 8175	01	06 05 254 800 8210	XX	06 05 722 800 8117	01	06 06 015 202 4010	03	06 06 294 100 6246	02	06 06 678 700 8175	01	06 05 256 600 5201	02	06 05 722 800 8120	01	06 06 018 500 8585	06	06 06 294 100 6246	03	06 06 694 500 8105	02	06 05 257 200 4201	04	06 05 737 400 7310	02	06 06 049 900 8145	02	06 06 300 100 8117	03	06 06 694 500 8110	02	06 05 313 500 8501	02	06 05 753 600 4210	02	06 06 051 400 8125	01	06 06 300 100 8120	03	06 06 698 400 5201	02	06 05 345 100 4301	02	06 05 769 502 4210	04	06 06 051 800 5810	01	06 06 303 800 6243	XX	06 06 704 700 8152	02	06 05 352 800 5810	01	06 05 774 500 3120	01	06 06 079 800 5803	01	06 06 303 900 6243	XX	06 06 704 800 8152	06	06 05 352 800 5815	01	06 05 774 600 3120	XX	06 06 079 900 5803	01	06 06 310 200 8117	01	06 06 705 100 8152	08	06 05 354 600 5101	02	06 05 774 700 3120	XX	06 06 097 300 4010	01	06 06 310 200 8120	01	06 06 715 000 1860	01	06 05 374 702 8221	02	06 05 774 800 3120	XX	06 06 107 300 8167	01	06 06 326 700 5201	01	06 06 718 400 8152	04	06 05 374 702 8225	02	06 05 774 900 3120	02	06 06 107 300 8170	01	06 06 326 702 5201	01	06 06 732 602 7001	01	06 05 381 300 7001	02	06 05 775 000 3120	02	06 06 107 400 8167	01	06 06 360 800 8225	01	06 06 732 700 7001	01	06 05 381 400 7001	02	06 05 785 200 3120	03	06 06 107 400 8170	01	06 06 370 000 4210	04	06 06 743 300 8402	14	06 05 385 900 6246	01	06 05 789 900 3130	03	06 06 107 500 8167	02	06 06 383 000 8520	03	06 06 743 300 8405	14	06 05 389 800 6246	01	06 05 801 002 5801	01	06 06 107 500 8170	02	06 06 391 100 3150	01	06 06 743 300 8410	14	06 05 389 800 6246	03	06 05 821 700 4315	02	06 06 107 900 8205	04	06 06 391 200 3150	01	06 06 800 400 8230	02	06 05 427 100 3150	01	06 05 825 700 4210	04	06 06 107 900 8210	04	06 06 412 500 8117	02	06 06 806 300 8152	10	06 05 478 200 1510	08	06 05 825 802 4210	04	06 06 120 000 5805	01	06 06 412 500 8120	02	06 06 806 900 8250	01	06 05 451 500 4210	02	06 05 850 300 4235	01	06 06 123 600 4301	08	06 06 417 200 8221	01	06 06 807 100 8250	01	06 05 505 100 8140	02	06 05 850 300 4315	01	06 06 152 700 8105	02	06 06 417 200 8230	01	06 06 821 000 8152	10	06 05 520 600 6132	02	06 05 864 100 6246	01	06 06 152 700 8110	02	06 06 430 000 8215	01	06 06 821 100 8152	10	06 05 520 600 8550	02	06 05 870 400 4210	04	06 06 156 300 8402	12	06 06 433 400 8117	02	06 06 826 700 8130	01	06 05 530 102 5201	02	06 05 915 600 4315	01	06 06 156 300 8405	12	06 06 433 400 8120	02	06 06 831 100 8205	02	06 05 530 123 5201	02	06 05 921 100 5805	01	06 06 156 300 8410	12	06 06 452 500 8240	02	06 06 831 100 8210	02	06 05 548 500 8205	02	06 05 921 100 5805	02	06 06 162 800 5805	01	06 06 452 600 8240	02	06 06 863 700 8205	01	06 05 548 500 8210	02	06 05 925 300 8225	02	06 06 162 900 5805	01	06 06 452 800 8240	02	06 06 863 700 8210	01	06 05 550 600 8205	02	06 05 982 800 3140	10	06 06 180 200 8215	02	06 06 452 900 8240	02	06 06 875 400 8240	02

1 Numéro des pièces - Delnumre - Ersatzteilnummer - Part Number - Numeros de las piezas - Numero del pezzo - Nummers der onderdelen - Reservdelnummer

2 Numéro des planches - Planche-Numre - Bildtafelnummer - Plate Number - Numeros de las laminas - Numero della tavola - Nummers der afbeeldingen - Bildnummer

3 Quantité par véhicule - Antal pr. vogn - Menge pro fahrzg - Quantity per vehicle - Cantidad por vehículo - Quantita per veicolo - Aant. per wagen - Antal per bil

						1			2			3			1			2			3		
						1	2	3	1	2	3	1	2	3	1	2	3	1	2	3	1	2	3
06 06 899 100 8225	02	06 07 075 000 6243	XX	06 07 163 302 3113	01	06 07 410 500 1575	01	06 07 905 400 6138	01														
06 06 899 200 8225	02	06 07 079 700 4020	02	06 07 163 900 3113	01	06 07 428 900 5805	01	06 08 008 900 1920	01														
06 06 917 300 8205	06	06 07 079 700 4030	04	06 07 166 200 1920	01	06 07 444 500 5805	01	06 08 013 200 3130	01														
06 06 917 300 8210	06	06 07 079 800 4020	01	06 07 172 100 3120	XX	06 07 457 202 1530	02	06 08 020 300 4301	02														
06 06 917 300 8221	XX	06 07 079 800 4030	02	06 07 201 602 1501	01	06 07 464 900 3150	01	06 08 020 400 4301	02														
06 06 932 900 8225	01	06 07 079 802 4020	01	06 07 201 802 1530	02	06 07 475 500 8501	01	06 08 021 000 4201	04														
06 06 947 400 8145	02	06 07 079 802 4030	02	06 07 203 300 8901	02	06 07 492 300 7101	01	06 08 022 704 8205	01														
06 06 956 100 3120	01	06 07 079 900 4030	02	06 07 215 200 8501	01	06 07 494 800 7001	01	06 08 022 704 8210	01														
06 06 962 400 4301	02	06 07 079 902 4030	02	06 07 218 000 1501	01	06 07 523 200 7310	01	06 08 043 300 3140	02														
06 06 964 400 4020	02	06 07 080 100 4020	02	06 07 221 400 3113	01	06 07 528 400 1860	01	06 08 044 700 3140	01														
06 06 964 400 4030	04	06 07 081 500 1430	02	06 07 229 800 1610	01	06 07 528 402 1860	01	06 08 044 900 6243	01														
06 06 968 600 4020	02	06 07 103 300 7301	01	06 07 239 200 6118	01	06 07 528 407 1860	01	06 08 050 400 3130	01														
06 06 968 600 4030	02	06 07 103 400 7301	01	06 07 239 200 6138	02	06 07 531 500 1440	01	06 08 050 500 3130	01														
06 06 968 700 4020	02	06 07 109 900 7001	01	06 07 239 200 6240	01	06 07 531 502 1440	01	06 08 054 200 4301	01														
06 06 968 900 4030	02	06 07 113 900 8545	02	06 07 246 800 1880	01	06 07 532 000 1510	08	06 08 073 400 1860	01														
06 06 979 600 6028	02	06 07 119 300 8240	02	06 07 247 100 1430	01	06 07 532 100 1510	08	06 08 084 000 4301	02														
06 06 979 600 6031	02	06 07 127 300 1530	01	06 07 256 400 3130	01	06 07 544 100 8146	12	06 08 112 700 1440	04														
06 06 983 500 4030	04	06 07 148 500 1610	01	06 07 256 700 3150	01	06 07 544 102 8117	02	06 08 169 000 5801	01														
06 06 984 000 4030	04	06 07 148 502 1610	01	06 07 256 800 3120	01	06 07 544 102 8120	02	06 08 169 000 5803	01														
06 07 001 300 5801	01	06 07 149 100 1440	01	06 07 258 700 3120	01	06 07 544 102 8146	12	06 08 178 502 4301	04														
06 07 001 300 5803	01	06 07 150 300 1530	01	06 07 259 000 4030	04	06 07 564 600 1510	08	06 08 180 500 1890	01														
06 07 009 000 3150	01	06 07 152 300 1440	04	06 07 281 700 1510	03	06 07 577 400 6128	01	06 08 191 000 3120	01														
06 07 026 900 5815	01	06 07 153 200 1510	01	06 07 287 700 8580	02	06 07 625 900 5201	01	06 08 202 700 3113	01														
06 07 027 800 8167	02	06 07 153 700 1510	03	06 07 308 200 8240	04	06 07 631 800 1510	01	06 08 207 200 5101	02														
06 07 027 800 8175	01	06 07 153 800 1510	02	06 07 315 100 1510	03	06 07 634 100 1510	08	06 08 209 000 5830	12														
06 07 027 800 8177	01	06 07 153 900 1501	01	06 07 321 500 6240	01	06 07 642 800 1530	02	06 08 209 902 5830	12														
06 07 040 700 8152	02	06 07 154 000 1501	01	06 07 325 600 4201	02	06 07 644 200 1510	08	06 08 217 000 4301	01														
06 07 042 400 8545	02	06 07 154 202 1501	02	06 07 329 400 1530	01	06 07 747 900 1501	08	06 08 217 100 4301	01														
06 07 042 400 8545	04	06 07 155 000 1601	01	06 07 329 500 1570	01	06 07 768 400 8402	02	06 08 233 900 4301	01														
06 07 045 200 3120	XX	06 07 155 100 1601	01	06 07 329 600 1530	01	06 07 776 500 1440	04	06 08 237 902 5201	02														
06 07 045 300 3120	XX	06 07 155 200 1601	01	06 07 329 700 1510	08	06 07 776 600 1440	04	06 08 247 300 7310	01														
06 07 045 400 3120	XX	06 07 155 700 1880	01	06 07 332 200 1575	02	06 07 776 700 1440	04	06 08 248 200 7310	01														
06 07 045 500 3120	XX	06 07 156 400 1601	01	06 07 378 200 1510	01	06 07 801 600 1440	08	06 08 270 000 4201	04														
06 07 045 600 3120	XX	06 07 156 600 1510	01	06 07 391 800 8125	02	06 07 805 200 8240	02	06 08 275 400 3110	02														
06 07 045 700 3120	XX	06 07 156 700 1510	01	06 07 396 400 5201	01	06 07 857 300 1530	01	06 08 331 902 5201	02														
06 07 045 800 3120	XX	06 07 158 600 3113	01	06 07 396 500 5201	01	06 07 887 702 1430	02	06 08 349 302 5201	02														
06 07 056 900 5101	04	06 07 158 602 3113	01	06 07 396 502 5201	01	06 07 958 800 6031	02	06 08 399 002 1430	14														
06 07 057 300 8250	01	06 07 160 800 8140	01	06 07 407 702 1501	02	06 07 966 200 3120	01	06 08 407 000 1601	01														
06 07 059 202 1575	02	06 07 162 700 3120	01	06 07 407 702 1501	03	06 07 977 800 3120	01	06 08 432 300 8205	02														
06 07 074 900 6243	XX	06 07 163 300 3113	01	06 07 410 400 1575	01	06 07 992 400 4010	01	06 08 432 300 8210	02														

1 Numéro des pièces - Delnumre - Ersatzteilnummer - Part Number - Numeros de las piezas - Numero del pezzo - Nummers der onderdelen - Reservedelsnummer

2 Numéro des planches - Planche-Numre - Bildtafelnummer - Plate Number - Numeros de las laminas - Numero della tavola - Nummers der afbeeldingen - Bildnummer

3 Quantité par véhicule - Antal pr. vogn - Menge pro fahrzg - Quantity per vehicle - Cantidad por vehículo - Quantita per veicolo - Aant. per wagen - Antal per bil

				1			2			3			1			2			3																																																																																																																																																																																																																																																																																																																																																																																																						
06 08 437 209 1430	01	07 06 198 300 1430	10	07 06 305 400 1501	10	07 70 600 800 3120	01	08 10 008 000 8105	01	06 08 448 502 8205	02	07 06 204 200 6240	01	07 06 312 400 1440	08	07 70 620 320 1810	01	08 10 008 000 8110	01	06 08 448 502 8210	02	07 06 214 000 4201	04	07 06 312 600 5801	01	07 70 620 340 1810	01	08 11 936 900 5825	01	06 08 450 002 1501	02	07 06 214 700 8180	01	07 06 312 600 5803	01	07 70 620 700 3120	01	08 12 056 900 5805	01	06 08 475 400 5801	01	07 06 214 700 8190	01	07 06 313 200 8105	04	07 70 630 621 4210	02	08 12 068 800 5820	01	06 08 515 700 3120	01	07 06 232 400 1501	10	07 06 313 200 8110	04	07 72 590 900 3130	03	08 12 068 900 5820	01	06 08 554 100 6246	02	07 06 232 700 4010	01	07 06 315 906 4030	04	07 72 594 800 1601	01	08 20 315 800 8140	01	06 60 432 700 8140	01	07 06 241 602 1575	02	07 06 316 000 4210	02	07 73 020 300 3120	02	08 20 321 500 8167	01	06 60 432 700 8225	XX	07 06 243 400 1501	01	07 06 316 102 1920	01	07 73 020 400 4301	02	08 20 321 500 8170	01	06 60 432 700 8230	XX	07 06 251 600 4010	04	07 06 328 500 4301	08	07 73 020 600 4301	02	08 20 321 600 8167	01	07 02 991 600 1430	01	07 06 252 600 4201	04	07 06 329 302 5201	02	07 73 020 800 3140	01	08 20 321 600 8170	01	07 03 260 200 7101	03	07 06 252 600 4301	04	07 06 329 400 1430	01	07 73 130 800 3140	01	08 20 322 200 8140	01	07 03 210 200 7101	03	07 06 252 602 4201	04	07 06 329 400 1501	04	07 75 020 600 4210	02	08 20 323 500 8167	01	07 03 230 200 7101	01	07 06 252 602 4301	04	07 06 329 500 1501	02	08 02 107 900 5825	01	08 20 323 500 8170	01	07 03 240 200 7101	01	07 06 259 200 1510	08	07 06 329 500 1501	02	08 02 120 300 1840	01	08 20 323 600 8167	01	07 03 308 100 1530	01	07 06 260 500 5830	04	07 06 331 300 4301	02	08 02 120 300 1840	01	08 20 323 600 8170	01	07 03 412 900 5803	04	07 06 260 602 1920	01	07 06 331 302 4301	02	08 02 120 600 1840	01	08 20 323 600 8170	01	07 03 500 100 1510	01	07 06 260 602 1920	01	07 06 331 702 5201	02	08 02 120 700 1840	01	08 20 323 800 8120	01	07 03 500 600 1440	01	07 06 263 300 8545	02	07 06 335 202 1701	03	08 02 121 700 1840	02	08 20 324 500 8125	01	07 03 621 300 5805	01	07 06 267 500 1430	10	07 06 347 802 3110	02	08 02 121 800 1840	01	08 20 330 900 8225	01	07 03 621 300 5805	01	07 06 271 900 5825	01	07 10 937 700 1510	08	08 02 454 000 1840	02	08 20 331 800 8215	01	07 03 621 300 5805	02	07 06 271 900 8117	02	07 10 941 000 1501	08	08 02 494 100 7001	01	08 20 344 300 8520	01	07 05 129 800 8402	01	07 06 271 900 8120	02	07 10 941 100 1501	08	08 02 612 700 1541	01	08 20 344 400 8520	01	07 05 339 100 5810	01	07 06 271 900 8402	01	07 50 760 900 1920	01	08 02 612 700 1543	01	08 20 345 100 8105	01	07 05 339 100 5815	01	07 06 274 700 4010	04	07 50 763 800 1920	01	08 02 613 100 1543	01	08 20 348 100 8117	01	07 05 562 800 5825	01	07 06 276 100 4301	02	07 60 428 800 5815	01	08 02 613 200 1541	01	08 20 364 900 8240	01	07 05 604 200 8250	01	07 06 278 600 3110	02	07 60 428 800 8140	02	08 02 613 200 1543	02	08 20 365 000 8240	01	07 05 604 300 7101	01	07 06 281 502 1920	01	07 60 432 001 7101	XX	08 02 613 300 1541	01	08 20 366 500 8140	01	07 05 665 200 5810	01	07 06 284 100 1530	02	07 60 434 100 8250	01	08 02 613 300 1543	01	08 20 383 800 8125	01	07 05 665 200 5815	01	07 06 285 700 4020	01	07 60 447 200 1920	01	08 02 613 500 1541	01	08 20 383 900 8125	01	07 05 905 400 6230	02	07 06 290 900 4201	04	07 60 447 200 1920	02	08 02 613 500 1543	01	08 20 387 700 8167	01	07 05 905 400 6230	03	07 06 290 900 4301	04	07 60 472 700 5830	01	08 02 613 705 1545	01	08 20 387 700 8170	01	07 05 914 602 1501	03	07 06 290 902 4201	04	07 60 472 700 5830	02	08 02 614 543 1545	01	08 20 388 600 8140	01	07 05 961 100 7001	01	07 06 290 902 4301	04	07 60 472 700 5830	03	08 02 614 545 1545	01	08 20 390 000 8136	01	07 06 034 100 5801	01	07 06 291 000 3130	03	07 60 472 700 5830	04	08 02 614 801 1545	01	08 20 393 100 8125	01	07 06 034 100 5803	01	07 06 292 700 1440	05	07 60 472 700 5830	09	08 02 614 900 1541	01	08 20 394 500 7101	01	07 06 169 700 1810	01	07 06 292 700 1440	07	07 60 473 700 8901	01	08 02 614 900 1543	01	08 20 425 600 8205	01	07 06 177 800 5810	01	07 06 294 502 3110	11	07 60 493 700 1501	01	08 02 629 300 6130	03	08 20 426 300 8205	01	07 06 177 800 5815	01	07 06 296 802 1530	02	07 60 706 300 1501	01	08 02 629 300 6132	03	08 20 426 300 8210	01	07 06 178 300 6128	01	07 06 303 200 5810	01	07 60 712 000 8205	01	08 02 629 300 6134	03	08 20 426 600 8205	01	07 06 178 400 7101	01	07 06 303 200 5815	01	07 60 712 000 8210	01	08 02 724 000 1901	02	08 20 426 600 8210	01

1 Numéro des pièces - Delnumre - Ersatzteilnummer - Part Number - Numeros de las piezas - Numero del pezzo - Nummers der onderdelen - Reservedelsnummer

2 Numéro des planches - Planche-Numre - Bildtafelnummer - Plate Number - Numeros de las laminas - Numero della tavola - Nummers der afbeeldingen - Bildnummer

3 Quantité par véhicule - Antal pr. vogn - Menge pro fahrzg - Quantity per vehicle - Cantidad por vehículo - Quantita per veicolo - Aant. per wagen - Antal per bil

					1			2			3			1			2			3		
					1	2	3	1	2	3	1	2	3	1	2	3	1	2	3	1	2	3
08 20 427 700 8205	C1	08 21 325 900 8175	01	08 21 478 500 8175	01	08 21 547 700 7301	01	08 21 748 100 8175	01													
08 20 428 700 8430	C1	08 21 326 700 8167	01	08 21 408 600 8175	01	08 21 553 200 7301	01	08 21 748 200 8175	01													
08 20 428 800 8430	C1	08 21 326 400 8145	01	08 21 408 700 8175	01	08 21 554 400 4201	02	08 21 757 500 8105	01													
08 20 428 900 8430	C1	08 21 326 500 8145	01	08 21 408 700 8175	02	08 21 556 500 3150	01	08 21 757 600 8110	01													
08 20 430 700 8117	C1	08 21 327 900 8105	01	08 21 409 300 8177	01	08 21 557 200 8110	01	08 21 785 900 5017	01													
08 20 439 000 8110	C1	08 21 328 100 8167	01	08 21 409 400 8177	01	08 21 558 400 7310	01	08 21 785 800 5020	01													
08 20 441 800 8105	C1	08 21 328 100 8175	01	08 21 411 100 8901	01	08 21 598 100 7310	01	08 21 795 500 8175	01													
08 20 465 900 8110	C1	08 21 328 100 8177	01	08 21 411 500 8110	01	08 21 634 000 1440	01	08 21 795 600 8175	01													
08 20 491 100 8230	C1	08 21 328 200 8167	01	08 21 411 600 8105	01	08 21 642 600 5010	01	08 22 468 200 7801	01													
08 20 512 700 8117	C1	08 21 328 200 8175	01	08 21 416 400 8152	01	08 21 644 700 8501	01	08 22 597 551 4201	02													
08 20 514 200 8105	C1	08 21 328 200 8177	01	08 21 416 600 8152	01	08 21 660 800 5020	01	08 22 597 651 4201	02													
08 20 514 400 8117	C1	08 21 328 300 8167	01	08 21 418 300 8135	01	08 21 662 500 4220	02	08 22 604 900 8585	02													
08 20 515 100 7310	C1	08 21 328 300 8170	01	08 21 432 500 8250	01	08 21 662 599 4220	02	08 22 604 902 8585	02													
08 20 517 500 8110	C1	08 21 328 400 8167	01	08 21 441 900 8105	01	08 21 663 600 4301	01	08 22 605 400 8125	01													
08 20 517 700 8120	C1	08 21 328 400 8170	01	08 21 442 900 8125	01	08 21 664 200 8130	01	08 22 628 000 8130	01													
08 20 571 600 8221	C1	08 21 329 000 8105	01	08 21 443 900 8225	01	08 21 664 300 8130	01	08 22 628 400 8130	01													
08 20 575 700 8167	C1	08 21 329 200 8105	01	08 21 444 000 8590	01	08 21 670 000 8105	01	08 22 646 600 8145	01													
08 20 588 300 8167	C1	08 21 330 500 8117	01	08 21 451 300 8167	01	08 21 670 100 8110	01	08 22 647 800 8149	01													
08 20 607 900 4301	C1	08 21 330 600 8117	01	08 21 452 500 8167	01	08 21 670 800 7310	01	08 22 660 000 8215	01													
08 20 612 000 8135	C1	08 21 331 000 8105	01	08 21 453 700 8140	01	08 21 671 600 8167	01	08 22 663 200 8580	02													
08 20 612 100 8135	C1	08 21 332 000 6132	01	08 21 463 800 8520	01	08 21 688 000 8125	01	08 22 678 300 8590	01													
08 20 614 500 8120	C1	08 21 332 000 8550	01	08 21 473 600 8225	01	08 21 688 400 8125	01	08 22 700 800 8520	01													
08 20 614 600 8120	C1	08 21 337 700 8175	01	08 21 473 700 4020	01	08 21 689 000 8125	01	08 22 703 900 4010	01													
08 20 614 700 8117	C1	08 21 337 800 8175	01	08 21 473 800 4020	01	08 21 691 100 1501	01	08 22 723 700 8125	01													
08 20 615 200 8117	C1	08 21 337 900 8175	01	08 21 476 300 8125	01	08 21 701 000 8125	01	08 22 723 800 8125	01													
08 20 615 300 8120	C1	08 21 337 900 8177	01	08 21 476 400 8125	01	08 21 701 100 8125	01	08 22 723 900 8125	01													
08 20 643 600 4201	C1	08 21 338 000 8175	01	08 21 476 500 8580	01	08 21 701 400 8125	01	08 22 725 700 8140	01													
08 20 643 700 4201	C1	08 21 338 000 8177	01	08 21 481 400 8230	01	08 21 704 300 7310	01	08 22 730 300 8152	02													
08 20 652 900 4301	C1	08 21 339 900 8550	01	08 21 482 300 8105	01	08 21 712 200 8167	01	08 22 736 800 8145	01													
08 20 684 300 8105	C1	08 21 340 000 8110	01	08 21 482 300 8110	01	08 21 712 200 8167	02	08 22 737 400 8140	01													
08 20 737 000 8430	C1	08 21 343 900 8110	01	08 21 490 200 1501	01	08 21 712 300 8167	01	08 22 799 000 5201	01													
08 20 737 100 8430	C1	08 21 346 000 8110	01	08 21 490 300 1501	01	08 21 736 000 8110	01	08 22 817 200 5803	01													
08 20 740 300 4201	C1	08 21 362 200 8110	01	08 21 499 600 5010	01	08 21 736 200 8105	01	08 22 817 300 5801	01													
08 20 741 400 8117	C1	08 21 367 800 8120	01	08 21 499 600 5020	01	08 21 736 900 8175	01	08 22 820 300 1430	01													
08 20 754 600 8117	C1	08 21 378 100 8120	01	08 21 516 800 8580	01	08 21 738 000 8136	01	08 22 820 500 1440	01													
08 21 325 400 8167	C1	08 21 393 700 8170	01	08 21 540 900 5010	01	08 21 738 100 8136	01	08 22 821 900 1601	01													
08 21 325 500 8167	C1	08 21 393 800 8170	01	08 21 541 000 5020	01	08 21 738 200 8138	01	08 22 822 000 1601	01													
08 21 325 600 8167	C1	08 21 396 200 8105	01	08 21 541 100 5010	01	08 21 738 300 8138	01	08 22 845 500 7801	01													
08 21 325 700 8167	C1	08 21 396 200 8110	01	08 21 541 200 5020	01	08 21 746 800 4220	02	08 22 877 300 7301	01													
08 21 325 800 8167	C1	08 21 406 400 8125	01	08 21 541 300 3150	01	08 21 746 899 4220	02	08 22 884 000 3150	01													

1 Numéro des pièces - Delnumre - Ersatzteilnummer - Part Number - Numeros de las piezas - Numero del pezzo - Nummers der onderdelen - Reservedelsnummer

2 Numéro des planches - Planche-Numre - Bildtafelnummer - Plate Number - Numeros de las laminas - Numero della tavola - Nummers der afbeeldingen - Bildnummer

3 Quantité par véhicule - Antal pr. vogn - Menge pro fahrzg - Quantity per vehicle - Cantidad por vehículo - Quantita per veicolo - Aant. per wagen - Antal per bil

					1			2			3			1			2			3		
					1	2	3	1	2	3	1	2	3	1	2	3	1	2	3	1	2	3
C8 22 891 200 8130	01	08 23 876 300 5803	01	08 24 346 800 8152	02	08 32 026 400 8180	01	08 33 110 302 8180	01													
C8 22 891 200 8135	01	08 23 878 100 5830	02	08 24 358 000 8140	01	08 32 026 500 8180	01	08 33 132 600 4301	01													
C8 22 926 300 8501	01	08 23 878 200 5830	02	08 24 358 002 8140	01	08 32 028 200 4201	02	08 33 143 500 4010	01													
08 22 926 500 8501	01	08 23 880 000 4020	01	08 24 379 700 5801	01	08 32 028 300 4201	02	08 33 143 700 4010	01													
C8 22 972 600 8145	02	08 23 896 300 1750	01	08 24 383 600 3120	01	08 32 031 400 8555	01	08 33 167 900 8152	02													
C8 22 988 600 8555	01	08 23 896 302 1750	01	08 24 389 500 1610	01	08 32 031 500 8555	01	08 33 197 300 1440	01													
08 22 988 700 8555	01	08 23 896 700 3130	01	08 24 392 700 3120	01	08 32 054 800 8130	01	08 33 197 500 1440	01													
08 23 992 100 5801	01	08 23 897 700 1601	01	08 24 408 800 8105	01	08 32 075 000 1440	01	08 50 529 800 7801	01													
C8 23 600 000 4301	02	08 23 915 700 3130	01	08 24 409 000 1575	01	08 32 083 000 5201	01	08 50 667 500 1840	01													
C8 23 603 600 8205	02	08 23 917 300 1750	01	08 24 426 900 8105	01	08 32 084 800 8177	01	08 50 911 900 8140	02													
C8 23 603 600 8210	02	08 23 917 302 1750	01	08 24 469 900 1575	01	08 32 084 900 8177	01	08 50 967 400 1543	01													
C8 23 658 300 5010	01	08 23 921 500 1430	01	08 24 495 300 4301	01	08 32 091 500 8152	02	08 50 967 500 1543	01													
C8 23 658 300 5020	01	08 23 925 300 8145	01	08 24 517 900 8205	02	08 32 113 400 8501	01	08 51 056 900 5825	01													
C8 23 658 400 5010	01	08 23 925 400 8145	01	08 24 517 900 8210	02	08 32 114 100 8501	01	08 51 058 900 6045	01													
C8 23 658 400 5020	01	08 23 936 200 1510	01	08 30 018 300 8215	01	08 32 122 200 5801	01	08 51 058 900 6045	02													
C8 23 660 100 5810	01	08 23 946 100 3113	01	08 30 027 100 5201	02	08 32 122 300 5801	01	08 51 126 900 4020	02													
C8 23 660 100 5815	01	08 23 946 200 3113	01	08 30 027 700 5101	02	08 32 143 400 8130	01	08 51 127 500 4210	02													
C8 23 660 200 5810	01	08 23 953 900 5010	01	08 30 029 500 3113	02	08 32 143 400 8135	01	08 51 208 600 8140	04													
08 23 661 500 5810	01	08 23 953 900 5020	01	08 30 029 500 4201	01	08 32 143 500 8130	01	08 51 210 600 8901	02													
08 23 672 700 8190	01	08 23 954 000 5010	01	08 30 030 200 5101	02	08 32 143 500 8135	01	08 51 248 300 3110	02													
C8 23 683 700 5815	01	08 23 954 000 5020	01	08 30 037 800 8405	02	08 33 050 300 8221	01	08 51 250 100 4230	01													
08 23 684 900 5815	01	08 23 959 802 8190	01	08 30 037 800 8410	02	08 33 050 400 8221	01	08 51 250 200 4230	01													
C8 23 685 100 8215	02	08 23 972 600 8110	01	08 30 052 900 8215	02	08 33 057 400 4301	02	08 51 297 000 1530	01													
C8 23 700 500 4010	01	08 24 129 300 8590	01	08 30 055 900 8135	02	08 33 067 000 8167	01	08 51 304 600 1901	03													
08 23 702 500 8145	01	08 24 237 500 5810	01	08 30 059 300 8501	01	08 33 067 000 8167	02	08 51 304 900 1901	01													
08 23 736 900 8225	01	08 24 237 500 5815	01	08 30 061 911 8135	02	08 33 067 300 8145	02	08 51 305 000 1901	01													
C8 23 739 100 5830	01	08 24 253 000 4301	02	08 30 801 604 8205	01	08 33 077 800 8167	01	08 51 305 100 1901	01													
C8 23 739 300 5830	01	08 24 262 000 5810	01	08 30 801 604 8210	01	08 33 077 900 8167	01	08 51 305 300 1901	01													
08 23 739 500 5830	01	08 24 262 000 5815	01	08 30 801 704 8205	01	08 33 080 600 6001	01	08 51 305 400 1901	01													
C8 23 740 000 5830	01	08 24 285 200 8117	02	08 30 801 704 8210	01	08 33 083 000 6230	01	08 51 305 500 1901	01													
08 23 740 100 5830	01	08 24 285 200 8120	02	08 32 001 600 5010	02	08 33 084 700 8167	02	08 51 305 800 1901	02													
C8 23 747 400 5830	01	08 24 294 000 8205	02	08 32 001 600 5020	02	08 33 084 700 8170	02	08 51 305 900 1901	02													
C8 23 788 100 4210	04	08 24 294 000 8210	02	08 32 003 300 5101	02	08 33 097 000 5801	01	08 51 306 200 1901	01													
C8 23 797 900 5010	02	08 24 306 100 8130	01	08 32 003 600 4301	02	08 33 097 100 5803	01	08 51 306 400 1901	01													
08 23 797 900 5020	02	08 24 306 200 8130	01	08 32 006 600 4210	02	08 33 097 500 3130	01	08 51 355 800 4230	24													
C8 23 801 600 8125	01	08 24 315 100 8180	01	08 32 008 700 5010	01	08 33 097 600 3120	01	08 51 366 500 8430	10													
C8 23 805 000 8145	01	08 24 315 100 8190	01	08 32 008 900 5020	01	08 33 097 800 5830	01	08 51 367 200 4310	18													
C8 23 810 200 7101	01	08 24 322 500 6001	01	08 32 009 800 5803	01	08 33 097 900 5830	01	08 51 478 600 6116	01													
08 23 860 000 4010	01	08 24 326 100 8180	01	08 32 009 900 5801	01	08 33 098 000 5830	01	08 51 478 600 6117	02													
C8 23 860 100 4010	01	08 24 326 100 8190	01	08 32 023 100 8180	01	08 33 101 000 4020	01	08 51 478 600 8205	02													

1 Numéro des pièces - Delnumre - Ersatzteilnummer - Part Number - Numeros de las piezas - Numero del pezzo - Nummers der onderdelen - Reservedelsnummer

2 Numéro des planches - Planché-Numre - Bildtafelnummer - Plate Number - Numeros de las laminas - Numero della tavola - Nummers der afbeeldingen - Bildnummer

3 Quantité par véhicule - Antal pr. vogn - Menge pro fahrzg - Quantity per vehicle - Cantidad por vehículo - Quantita per veicolo - Aant. per wagen - Antal per bil

		1			2			3			1			2			3		
08 51 478 600 8210	02	08 51 993 700 4001	01	08 52 487 200 6040	02	08 52 307 800 8545	01	08 53 063 600 8210	02										
08 51 478 600 8221	02	08 51 993 800 4001	01	08 52 491 600 4601	01	08 52 312 500 8250	01	08 53 064 700 7001	01										
08 51 478 652 6116	01	08 51 994 900 4001	01	08 52 492 600 6035	01	08 52 312 600 8250	01	08 53 064 800 7001	01										
08 51 478 652 6117	02	08 51 996 600 6130	08	08 52 631 800 8901	02	08 52 316 300 8545	01	08 53 064 900 7001	01										
08 51 478 652 8205	02	08 51 996 600 6132	08	08 52 631 900 7001	01	08 52 319 500 8240	01	08 53 065 000 7001	01										
08 51 478 652 8210	02	08 51 996 600 6134	08	08 52 632 000 7001	02	08 52 319 600 8240	01	08 53 065 200 7001	01										
08 51 478 652 8221	02	08 52 022 700 1543	03	08 52 632 100 1560	02	08 52 328 800 8240	01	08 53 066 200 7001	01										
08 51 501 600 6120	01	08 52 036 200 1840	02	08 52 635 400 4301	04	08 52 329 200 8175	01	08 53 066 400 7001	01										
08 51 518 200 1901	01	08 52 037 300 4001	01	08 52 661 100 8545	02	08 52 330 400 7001	01	08 53 066 700 7001	01										
08 51 566 900 5803	02	08 52 125 300 6035	01	08 52 661 100 8545	03	08 52 330 500 7001	01	08 53 504 400 1541	01										
08 51 621 400 6035	01	08 52 174 400 1843	01	08 52 670 900 8225	01	08 52 333 800 1430	01	08 53 504 400 1543	01										
08 51 657 800 1541	01	08 52 175 400 1843	01	08 52 681 900 6142	01	08 52 346 000 1530	01	08 53 509 100 4015	01										
08 51 697 800 1543	01	08 52 184 501 1545	01	08 52 720 200 8125	01	08 52 351 800 3120	01	08 53 509 200 4015	01										
08 51 702 300 1541	04	08 52 257 200 6035	01	08 52 726 900 8240	01	08 52 360 300 8221	01	08 53 513 000 8146	12										
08 51 702 300 1543	04	08 52 257 300 6035	01	08 52 737 900 8225	01	08 52 388 009 3110	35	08 53 514 800 6040	01										
08 51 759 900 6028	01	08 52 257 400 6035	01	08 52 744 000 8240	02	08 52 389 700 1530	02	08 53 514 800 6040	02										
08 51 759 900 6028	02	08 52 257 500 6035	01	08 52 754 500 8550	01	08 52 394 300 8545	01	08 53 515 000 6055	01										
08 51 765 800 5110	02	08 52 257 600 6035	01	08 52 754 500 8550	02	08 52 395 500 3110	02	08 53 515 000 6061	01										
08 51 765 900 5110	04	08 52 257 700 6035	01	08 52 758 000 8240	02	08 52 396 600 7001	01	08 53 515 100 6055	01										
08 51 766 000 5110	03	08 52 257 900 6035	01	08 52 758 100 8240	02	08 52 398 300 1501	02	08 53 515 100 6061	01										
08 51 766 000 5110	04	08 52 258 200 8430	21	08 52 758 700 8240	02	08 52 398 300 1501	03	08 53 515 400 6055	01										
08 51 797 000 4230	02	08 52 260 000 1901	01	08 52 758 800 8240	02	08 52 399 000 1570	01	08 53 515 400 6058	01										
08 51 798 700 1860	04	08 52 278 200 5110	01	08 52 764 000 8205	01	08 52 399 100 1570	01	08 53 515 400 6061	01										
08 51 823 100 6138	02	08 52 278 200 5110	02	08 52 764 100 8205	01	08 52 399 900 1580	01	08 53 515 500 6061	01										
08 51 825 200 6120	02	08 52 278 300 5110	02	08 52 778 800 8901	02	08 52 413 300 4310	01	08 53 516 900 6230	01										
08 51 838 900 8140	04	08 52 278 300 5110	03	08 52 780 400 8250	01	08 52 413 400 4310	01	08 53 523 300 8550	03										
08 51 847 500 1843	01	08 52 287 700 4235	02	08 52 780 500 8250	01	08 52 423 200 8545	01	08 53 523 300 8550	06										
08 51 874 100 1843	01	08 52 289 700 4235	04	08 52 784 600 8410	01	08 52 424 500 8240	01	08 53 525 800 6055	01										
08 51 880 200 4230	01	08 52 289 700 4315	04	08 52 784 700 8410	01	08 52 427 300 8402	01	08 53 540 700 3140	02										
08 51 880 300 4230	01	08 52 290 300 4310	01	08 52 785 600 8240	02	08 52 427 400 8402	01	08 53 561 800 6040	01										
08 51 880 400 4230	01	08 52 290 400 4310	01	08 52 792 200 6110	01	08 52 437 800 1430	01	08 53 561 900 6040	01										
08 51 880 500 4230	01	08 52 305 000 1840	01	08 52 792 700 8210	01	08 52 437 900 1430	01	08 53 578 300 6040	01										
08 51 919 300 1830	01	08 52 305 000 1840	02	08 52 792 800 8210	01	08 52 439 600 8221	02	08 53 582 300 1541	02										
08 51 919 300 1830	02	08 52 324 300 7301	01	08 52 801 100 8240	02	08 52 439 900 8221	01	08 53 582 300 1543	01										
08 51 928 300 3001	01	08 52 324 300 7310	02	08 52 801 200 8240	02	08 52 450 000 8250	01	08 53 584 200 6028	01										
08 51 928 700 3001	01	08 52 342 300 3001	01	08 52 801 300 8240	02	08 52 450 100 8250	01	08 53 584 372 6028	01										
08 51 974 700 4235	01	08 52 356 800 1833	02	08 52 801 400 8240	02	08 52 452 600 8250	01	08 53 584 389 6028	01										
08 51 983 500 4001	02	08 52 449 800 4230	01	08 52 801 500 8221	02	08 52 452 700 8250	01	08 53 598 700 4201	08										
08 51 984 000 4001	01	08 52 482 300 8520	01	08 52 801 500 8230	02	08 52 455 700 8402	01	08 53 618 400 6028	01										
08 51 986 000 4001	01	08 52 487 200 6040	01	08 52 803 000 8125	01	08 53 063 600 8205	02	08 53 630 100 1810	01										

1 Numéro des pièces - Delnumre - Ersatzteilnummer - Part Number - Numeros de las piezas - Numero del pezzo - Nummers der onderdelen - Reservedelsnummer

2 Numéro des planches - Planche-Numre - Bildtafelnummer - Plate Number - Numeros de las laminas - Numero della tavola - Nummers der afbeeldingen - Bildnummer

3 Quantité par véhicule - Antal pr. vogn - Menge pro fahrzg - Quantity per vehicle - Cantidad por vehículo - Quantita per veicolo - Aant. per wagen - Antal per bil

				1			2			3			1			2			3																																																																																																																																																																																																																																																																																																																																																																																												
08 53 633 100 8402	01	08 53 828 400 7801	01	08 53 991 100 6243	05	08 54 087 700 3120	01	08 54 176 700 4315	02	08 53 636 800 1810	02	08 53 828 700 8221	01	08 53 991 200 6243	02	08 54 088 500 6132	02	08 54 176 900 4235	01	08 53 648 700 6116	01	08 53 828 752 8221	01	08 53 996 433 1545	01	08 54 093 200 1701	01	08 54 176 900 4315	01	08 53 648 752 6116	01	08 53 829 300 1843	02	08 53 996 440 1545	01	08 54 103 000 4210	02	08 54 183 100 6058	01	08 53 659 900 6040	01	08 53 831 000 5010	04	08 54 004 600 4001	01	08 54 118 300 1580	01	08 54 184 300 6045	02	08 53 664 600 6120	02	08 53 831 000 5801	02	08 54 010 700 8402	01	08 54 120 600 1843	01	08 54 184 500 6045	02	08 53 664 900 6230	01	08 53 851 001 1545	01	08 54 010 800 8402	01	08 54 129 000 6055	01	08 54 185 200 6045	02	08 53 665 100 6116	01	08 53 856 600 1833	01	08 54 011 000 8402	01	08 54 130 500 5201	01	08 54 186 300 6005	04	08 53 671 500 1830	02	08 53 860 500 6130	03	08 54 011 100 8402	01	08 54 133 100 6130	02	08 54 187 800 6132	04	08 53 672 300 1830	01	08 53 860 500 6132	03	08 54 024 900 5815	01	08 54 133 100 6132	02	08 54 189 900 1830	01	08 53 672 500 1830	01	08 53 860 500 6134	03	08 54 026 602 8225	02	08 54 133 100 6134	02	08 54 189 100 1830	01	08 53 673 400 1830	01	08 53 863 500 6055	01	08 54 027 200 6058	01	08 54 133 300 6130	04	08 54 190 500 1843	02	08 53 673 600 1830	01	08 53 863 600 6055	01	08 54 046 700 1541	01	08 54 133 300 6132	04	08 54 193 100 8190	01	08 53 674 200 1830	01	08 53 863 600 6061	01	08 54 049 500 8402	01	08 54 133 300 6134	02	08 54 193 100 8190	01	08 53 674 300 1830	01	08 53 863 900 6055	01	08 54 051 700 1860	01	08 54 133 400 6130	02	08 54 197 700 1830	01	08 53 674 500 1830	01	08 53 863 900 6061	01	08 54 058 700 6001	01	08 54 133 400 6132	02	08 54 201 700 6130	04	08 53 674 700 1830	01	08 53 872 600 4235	02	08 54 059 900 6128	01	08 54 133 400 6134	04	08 54 201 700 6132	04	08 53 675 400 6040	01	08 53 872 600 4315	02	08 54 060 500 6130	01	08 54 136 700 5820	01	08 54 201 700 6134	04	08 53 675 400 6040	02	08 53 893 500 6120	01	08 54 060 500 6132	01	08 54 136 800 5820	01	08 54 201 800 6130	04	08 53 677 000 5110	01	08 53 899 600 3001	01	08 54 060 700 6130	04	08 54 141 600 1543	01	08 54 201 800 6134	04	08 53 678 800 1830	01	08 53 927 700 1541	03	08 54 060 700 6132	04	08 54 145 500 6230	01	08 54 201 900 6130	08	08 53 705 100 6040	01	08 53 937 500 3130	01	08 54 060 700 6134	04	08 54 145 800 8205	01	08 54 201 900 6132	08	08 53 712 500 1843	01	08 53 952 600 1833	01	08 54 063 300 1840	01	08 54 145 800 8210	01	08 54 201 900 6134	08	08 53 719 800 1541	02	08 53 954 700 5810	01	08 54 063 300 1840	01	08 54 145 852 8205	01	08 54 218 200 6055	01	08 53 723 300 6116	01	08 53 958 300 3001	12	08 54 063 800 1840	01	08 54 145 852 8210	01	08 54 218 200 6061	01	08 53 725 100 1833	01	08 53 958 300 3005	12	08 54 069 300 4001	04	08 54 145 852 8210	01	08 54 218 200 6061	01	08 53 733 700 4001	04	08 53 971 100 8221	01	08 54 069 400 4001	01	08 54 147 000 5110	02	08 54 218 300 6058	01	08 53 744 400 6058	01	08 53 971 100 8230	01	08 54 070 000 1833	01	08 54 149 500 4235	02	08 54 218 400 6058	01	08 53 750 500 6120	01	08 53 971 100 8230	01	08 54 076 500 3130	01	08 54 157 300 4001	01	08 54 220 100 5110	01	08 53 770 300 1541	01	08 53 971 500 4020	02	08 54 077 600 1833	02	08 54 157 900 6058	01	08 54 220 500 1840	XX	08 53 770 300 1543	02	08 53 977 900 1541	02	08 54 077 700 1833	01	08 54 161 000 5820	01	08 54 221 700 6001	01	08 53 771 500 6116	02	08 53 980 700 6120	01	08 54 077 800 1833	01	08 54 164 400 4235	02	08 54 226 300 6005	06	08 53 771 500 6117	01	08 53 990 400 6243	02	08 54 077 900 1833	01	08 54 166 900 6058	01	08 54 226 300 6007	06	08 53 772 900 6005	04	08 53 990 500 6243	09	08 54 078 000 1833	01	08 54 171 200 1830	04	08 54 232 300 6142	02	08 53 780 000 3130	01	08 53 990 600 6243	06	08 54 082 000 6130	02	08 54 171 300 1830	01	08 54 233 000 6001	01	08 53 790 700 6128	01	08 53 990 600 6243	06	08 54 082 000 6132	02	08 54 171 400 1830	01	08 54 239 800 6005	02	08 53 812 400 1843	02	08 53 990 700 6243	12	08 54 082 000 6134	02	08 54 171 600 1830	01	08 54 239 800 6007	02	08 53 818 200 6055	01	08 53 990 800 6243	38	08 54 082 100 6130	02	08 54 172 000 1830	02	08 54 240 100 6001	01	08 53 818 200 6061	01	08 53 991 000 6243	03	08 54 082 100 6132	02	08 54 175 800 5805	01	08 54 248 300 6058	01	08 53 818 200 6061	01	08 53 991 000 6243	03	08 54 082 100 6134	02	08 54 176 500 4315	02	08 54 250 300 6128	01

1 Numéro des pièces - Delnumre - Ersatzteilnummer - Part Number - Numeros de las piezas - Numero del pezzo - Nummers der onderdelen - Reservedelsnummer

2 Numéro des planches - Planché-Numre - Bildtafelnummer - Plate Number - Numeros de las laminas - Numero della tavola - Nummers der afbeeldingen - Bildnummer

3 Quantité par véhicule - Antal pr. vogn - Menge pro fahrzg - Quantity per vehicle - Cantidad por vehículo - Quantita per veicolo - Aant. per wagen - Antal per bil

				1			2			3			1			2			3																																																																																																																																																																																																																																																																																																																																																																																												
CE 54 251 200 1830	01	08 54 337 700 1860	01	08 54 378 400 6132	01	08 54 407 600 6130	02	08 54 494 000 5110	01	08 54 261 900 6101	01	08 54 340 400 4010	01	08 54 378 400 6134	01	08 54 407 700 6130	02	08 54 494 200 6061	01	08 54 261 900 6104	01	08 54 341 100 4315	02	08 54 378 500 6130	01	08 54 407 800 6130	02	08 54 507 400 6130	02	08 54 262 000 6101	01	08 54 343 300 8130	15	08 54 378 500 6132	01	08 54 411 200 6243	XX	08 54 514 100 6061	01	08 54 262 000 6104	01	08 54 344 300 8540	01	08 54 378 500 6134	01	08 54 411 900 1901	01	08 54 522 300 1541	01	08 54 264 300 8540	01	08 54 344 400 8540	01	08 54 378 600 6130	01	08 54 421 500 1541	01	08 54 522 300 1543	01	08 54 264 400 8540	01	08 54 348 300 1901	01	08 54 378 600 6132	01	08 54 422 000 8540	01	08 54 522 400 1541	01	08 54 264 600 8540	01	08 54 357 000 3001	03	08 54 378 600 6134	01	08 54 423 700 6240	02	08 54 522 400 1543	01	08 54 264 700 8540	01	08 54 357 100 3150	01	08 54 378 700 6130	01	08 54 428 200 6136	01	08 54 522 900 6028	02	08 54 265 700 1840	01	08 54 357 200 6240	03	08 54 378 700 6132	01	08 54 428 300 6136	02	08 54 522 900 6031	02	08 54 268 200 4001	01	08 54 357 300 6128	01	08 54 378 700 6134	01	08 54 428 400 6136	01	08 54 524 400 6028	02	08 54 268 500 1843	01	08 54 357 400 6128	01	08 54 378 800 6136	01	08 54 428 500 6136	01	08 54 524 500 6028	02	08 54 269 300 1843	01	08 54 357 500 6055	01	08 54 379 200 6010	01	08 54 428 600 6136	01	08 54 526 000 6010	01	08 54 269 500 1843	XX	08 54 360 100 6101	01	08 54 379 300 6010	01	08 54 428 700 6136	01	08 54 526 100 6010	01	08 54 269 800 1860	01	08 54 360 100 6104	01	08 54 379 400 6010	01	08 54 428 800 6136	01	08 54 526 200 6010	01	08 54 272 100 8402	01	08 54 360 400 6101	01	08 54 379 500 6010	01	08 54 428 900 6136	01	08 54 526 300 6132	02	08 54 281 200 1830	01	08 54 360 400 6104	01	08 54 379 800 6025	01	08 54 429 000 6136	01	08 54 526 400 6132	02	08 54 281 500 1830	01	08 54 360 800 6007	02	08 54 379 900 6025	01	08 54 429 100 6136	01	08 54 526 500 6130	02	08 54 281 600 1830	01	08 54 361 000 6007	02	08 54 380 000 6035	01	08 54 429 200 6136	01	08 54 526 500 6132	02	08 54 281 700 1830	01	08 54 361 100 6007	04	08 54 380 100 6035	01	08 54 429 300 6136	01	08 54 526 500 6134	02	08 54 281 800 1833	01	08 54 367 000 8225	01	08 54 380 200 6035	01	08 54 429 400 6136	01	08 54 526 600 6130	02	08 54 282 600 1833	01	08 54 367 700 1843	01	08 54 380 300 6035	01	08 54 429 600 6136	01	08 54 526 600 6132	02	08 54 282 700 4010	01	08 54 367 800 1843	01	08 54 380 400 8221	02	08 54 429 700 6136	01	08 54 526 600 6134	02	08 54 284 500 1830	01	08 54 368 000 1843	03	08 54 380 400 8230	02	08 54 430 000 6136	01	08 54 530 700 6045	02	08 54 286 800 4235	01	08 54 368 700 6007	02	08 54 380 500 8221	01	08 54 430 000 6142	01	08 54 531 300 6230	01	08 54 286 800 4315	01	08 54 369 000 4001	01	08 54 380 500 8230	01	08 54 442 600 6136	01	08 54 534 900 6120	01	08 54 286 800 6058	01	08 54 369 900 6007	02	08 54 380 600 8221	02	08 54 448 400 6142	01	08 54 535 100 6007	02	08 54 289 700 6058	01	08 54 371 600 6005	02	08 54 380 600 8230	02	08 54 450 200 1830	01	08 54 536 700 8430	20	08 54 289 800 6058	01	08 54 371 600 6007	02	08 54 381 000 6120	01	08 54 453 100 6145	01	08 54 537 400 6104	01	08 54 302 100 8125	01	08 54 375 600 3150	02	08 54 381 100 6120	01	08 54 455 000 6142	02	08 54 537 800 6101	01	08 54 302 500 8545	02	08 54 375 602 3151	02	08 54 381 200 6120	01	08 54 465 400 1843	01	08 54 541 600 6007	02	08 54 302 900 8545	04	08 54 378 000 6130	02	08 54 381 300 6120	01	08 54 468 500 1543	01	08 54 547 800 8225	02	08 54 309 900 8255	01	08 54 378 000 6132	02	08 54 384 300 6025	01	08 54 479 000 6136	01	08 54 552 000 6025	01	08 54 318 800 6110	01	08 54 378 000 6134	02	08 54 405 300 1901	01	08 54 482 100 6123	01	08 54 554 600 1830	01	08 54 318 900 6110	01	08 54 378 100 6130	02	08 54 405 400 1901	01	08 54 487 300 6061	01	08 54 554 700 1830	01	08 54 321 500 6142	01	08 54 378 100 6132	02	08 54 406 800 8405	08	08 54 488 200 6116	01	08 54 555 000 6028	01	08 54 330 400 6110	01	08 54 378 100 6134	02	08 54 406 800 8410	08	08 54 488 252 6116	01	08 54 555 100 6028	01	08 54 330 500 6128	01	08 54 378 300 6130	01	08 54 407 100 1860	04	08 54 489 100 6230	01	08 54 555 200 6028	01	08 54 331 200 6055	01	08 54 378 300 6132	01	08 54 407 400 6136	01	08 54 490 400 6005	02	08 54 555 300 6028	01	08 54 331 200 6061	01	08 54 378 400 6130	01	08 54 407 500 6130	02	08 54 491 100 6120	01	08 54 568 700 3130	01

1 Numéro des pièces - Delnumre - Ersatzteilnummer - Part Number - Numeros de las piezas - Numero del pezzo - Nummers der onderdelen - Reservdelnummer

2 Numéro des planches - Planche-Numre - Bildtafelnummer - Plate Number - Numeros de las laminas - Numero della tavola - Nummers der afbeeldingen - Bildnummer

3 Quantité par véhicule - Antal pr. vogn - Menge pro fahrzg - Quantity per vehicle - Cantidad por vehículo - Quantita per veicolo - Aant. per wagen - Antal per bil

				1			2			3			1			2			3		
08 54 571 800 6116	01	08 54 648 500 6053	01	08 54 754 700 1901	01	08 54 856 800 6116	01	08 54 901 700 1830	01												
08 54 571 852 6116	01	08 54 653 664 6037	01	08 54 754 800 1901	01	08 54 856 800 6117	01	08 54 904 100 1813	01												
08 54 572 400 6025	02	08 54 661 300 8125	06	08 54 754 900 1901	01	08 54 859 200 6005	02	08 54 904 800 1840	01												
08 54 575 200 6028	01	08 54 673 600 6120	01	08 54 758 700 5110	02	08 54 860 600 1813	01	08 54 905 300 6101	01												
08 54 576 100 6045	02	08 54 673 900 6037	01	08 54 758 800 5110	02	08 54 860 700 1813	01	08 54 905 300 6104	01												
08 54 583 200 6130	01	08 54 674 100 6037	01	08 54 759 600 1810	01	08 54 860 800 1813	01	08 54 905 800 6117	02												
08 54 583 200 6132	01	08 54 674 300 6037	02	08 54 760 600 1810	01	08 54 860 900 1813	02	08 54 905 852 6117	02												
08 54 583 300 6134	01	08 54 679 600 1750	01	08 54 761 200 1810	01	08 54 861 200 1813	01	08 54 906 100 1580	01												
08 54 583 400 6134	01	08 54 681 900 6130	02	08 54 761 400 1810	01	08 54 861 300 1813	02	08 54 908 500 1830	01												
08 54 583 900 6025	02	08 54 685 300 3113	02	08 54 761 500 1810	01	08 54 862 300 1580	01	08 54 909 600 1833	01												
08 54 591 200 6025	02	08 54 686 300 6013	02	08 54 761 600 1810	01	08 54 864 600 5810	01	08 54 910 100 1840	01												
08 54 592 000 1510	04	08 54 693 400 7001	01	08 54 763 100 6116	01	08 54 864 600 5815	01	08 54 910 200 1840	01												
08 54 592 002 1510	04	08 54 694 500 6240	01	08 54 766 100 5110	03	08 54 865 800 6230	02	08 54 910 300 1840	01												
08 54 592 009 1510	04	08 54 700 600 1813	01	08 54 769 200 6243	04	08 54 867 400 1540	01	08 54 912 200 3110	01												
08 54 593 600 1810	01	08 54 700 700 1813	02	08 54 769 300 6243	04	08 54 868 000 4010	01	08 54 912 300 3140	02												
08 54 593 900 1810	01	08 54 701 100 1813	01	08 54 769 600 8402	XX	08 54 868 800 6142	01	08 54 912 400 3120	01												
08 54 596 900 4030	04	08 54 701 200 1813	02	08 54 774 100 6001	01	08 54 875 200 6013	02	08 54 912 500 1540	01												
08 54 599 700 6128	01	08 54 701 300 1813	02	08 54 775 100 1830	01	08 54 875 300 6013	04	08 54 914 700 1813	01												
08 54 599 800 6025	02	08 54 701 700 1813	01	08 54 775 200 1830	01	08 54 875 400 6013	04	08 54 915 700 1833	01												
08 54 605 500 8150	42	08 54 701 800 1813	01	08 54 775 300 6001	01	08 54 875 500 6013	02	08 54 916 500 1833	01												
08 54 606 000 8150	03	08 54 704 100 1701	01	08 54 781 400 8540	01	08 54 880 100 6101	01	08 54 916 600 1833	01												
08 54 609 500 7001	02	08 54 707 400 8540	01	08 54 781 500 8540	01	08 54 880 200 6101	01	08 54 923 600 1840	01												
08 54 609 800 1830	01	08 54 707 500 8540	01	08 54 781 600 8540	01	08 54 884 800 1833	04	08 54 925 200 6117	01												
08 54 611 600 6025	01	08 54 707 600 5801	01	08 54 806 700 3150	01	08 54 886 000 1810	01	08 54 925 252 6117	01												
08 54 611 700 6025	01	08 54 721 000 5825	01	08 54 806 800 3150	01	08 54 886 500 8540	01	08 54 926 300 6117	01												
08 54 611 800 6025	01	08 54 725 300 1843	04	08 54 807 900 6001	01	08 54 886 600 8540	01	08 54 926 352 6117	01												
08 54 611 900 6025	01	08 54 727 000 1541	01	08 54 808 800 6045	01	08 54 887 600 1750	01	08 54 934 000 1580	01												
08 54 617 500 6007	02	08 54 727 000 1543	01	08 54 808 800 6045	02	08 54 887 700 1750	01	08 54 934 300 1580	01												
08 54 618 000 6007	02	08 54 729 900 1541	02	08 54 808 800 6101	01	08 54 888 100 1833	01	08 54 935 400 1580	01												
08 54 620 300 1901	01	08 54 731 000 1543	02	08 54 808 800 6104	01	08 54 888 200 1830	01	08 54 935 500 1580	01												
08 54 625 200 1541	01	08 54 732 700 1610	01	08 54 817 900 1833	01	08 54 891 600 5803	01	08 54 935 600 1580	01												
08 54 625 200 1543	01	08 54 734 700 1510	08	08 54 818 100 1830	01	08 54 895 300 1510	08	08 54 937 600 1810	01												
08 54 625 400 1541	01	08 54 735 400 1440	03	08 54 818 700 8540	01	08 54 895 500 1830	01	08 54 937 900 1810	01												
08 54 625 400 1543	01	08 54 737 000 1830	01	08 54 818 800 8540	01	08 54 897 900 1510	01	08 54 938 100 1810	01												
08 54 625 800 6128	01	08 54 740 300 1830	01	08 54 831 100 7001	XX	08 54 898 100 1610	01	08 54 939 200 6230	01												
08 54 626 500 6045	02	08 54 741 800 1541	01	08 54 837 900 5805	01	08 54 898 300 1430	01	08 54 942 900 1840	01												
08 54 626 600 1510	01	08 54 741 800 1543	01	08 54 838 000 5805	01	08 54 898 900 1810	01	08 54 943 000 1840	01												
08 54 627 500 1510	01	08 54 745 200 6005	02	08 54 844 800 6010	01	08 54 900 100 1840	01	08 54 943 100 1840	01												
08 54 638 400 4015	01	08 54 753 200 1833	01	08 54 855 800 6230	01	08 54 900 700 1840	01	08 54 943 200 1840	01												
08 54 645 000 1440	04	08 54 754 600 1901	01	08 54 856 600 6116	01	08 54 900 900 1840	XX	08 54 943 600 1840	01												

1 Numéro des pièces - Delnumre - Ersatzteilnummer - Part Number - Numeros de las piezas - Numero del pezzo - Nummers der onderdelen - Reservedelsnummer

2 Numéro des planches - Planche-Numre - Bildtafelnummer - Plate Number - Numeros de las laminas - Numero della tavola - Nummers der afbeeldingen - Bildnummer

3 Quantité par véhicule - Antal pr. vogn - Menge pro fahrzg - Quantity per vehicle - Cantidad por vehículo - Quantita per veicolo - Aant. per wagen - Antal per bil

				1			2			3			1			2			3		
08 54 943 700 1840	01	08 54 971 300 1541	01	08 54 989 100 1843	01	08 55 094 100 6145	01	08 55 266 500 9545	03												
08 54 943 800 1840	01	08 54 971 300 1543	01	08 54 989 300 1843	01	08 55 094 200 6145	01	08 55 273 200 6037	01												
08 54 943 900 1840	01	08 54 971 400 1541	01	08 54 989 500 6117	01	08 55 094 900 6145	01	08 55 273 300 6037	01												
08 54 947 100 1810	02	08 54 971 400 1543	01	08 54 994 100 1840	01	08 55 104 900 6104	01	08 55 294 300 1816	04												
08 54 947 200 1810	02	08 54 971 500 1541	02	08 54 994 200 1840	01	08 55 109 200 6136	01	08 55 300 200 1816	01												
08 54 951 400 6243	38	08 54 971 500 1541	04	08 54 994 300 1840	02	08 55 109 800 8540	01	08 55 306 900 1816	01												
08 54 951 500 6243	09	08 54 971 500 1543	02	08 55 057 700 4401	05	08 55 109 900 8540	01	08 55 307 000 1816	02												
08 54 951 600 6243	05	08 54 971 500 1543	04	08 55 062 500 6134	02	08 55 110 000 8540	01	08 55 307 100 1816	01												
08 54 954 600 1843	01	08 54 971 600 1541	01	08 55 062 800 1541	01	08 55 110 100 8540	01	08 55 307 200 1816	01												
08 54 954 700 4235	01	08 54 971 600 1543	01	08 55 063 200 1541	01	08 55 124 500 1830	01	08 55 307 300 1816	01												
08 54 954 800 4235	01	08 54 971 900 1541	01	08 55 064 300 1541	01	08 55 124 600 1830	01	08 55 307 400 1816	02												
08 54 955 400 1843	01	08 54 972 800 1541	01	08 55 064 300 1543	01	08 55 124 900 1830	01	08 55 307 500 1816	02												
08 54 955 600 1843	01	08 54 972 900 1541	01	08 55 066 600 6230	01	08 55 132 200 6101	04	08 55 307 600 1816	04												
08 54 955 700 1843	01	08 54 972 900 1543	01	08 55 069 900 1901	01	08 55 132 200 6104	04	08 55 307 700 1816	05												
08 54 956 100 6045	01	08 54 973 300 1541	01	08 55 079 400 7001	XX	08 55 132 700 8901	04	08 55 307 800 1816	01												
08 54 956 200 6101	01	08 54 973 300 1543	01	08 55 085 400 1548	01	08 55 132 800 3001	01	08 55 307 900 1816	02												
08 54 956 300 6104	01	08 54 973 500 1541	01	08 55 085 500 1548	01	08 55 132 800 3005	01	08 55 308 000 1816	01												
08 54 956 600 4235	02	08 54 973 500 1543	01	08 55 090 200 6142	01	08 55 135 364 6037	01	08 55 308 100 1816	02												
08 54 956 600 4315	02	08 54 973 600 1540	01	08 55 090 400 6142	01	08 55 173 100 3113	01	08 55 308 200 1816	01												
08 54 956 700 4235	02	08 54 973 600 1542	01	08 55 090 500 6142	01	08 55 173 900 1510	01	08 55 308 300 1816	01												
08 54 956 700 4315	02	08 54 973 700 1541	01	08 55 090 600 6142	01	08 55 174 000 1510	01	08 55 308 400 1816	01												
08 54 956 800 4230	01	08 54 973 700 1543	01	08 55 090 700 6142	01	08 55 175 500 3113	01	08 55 308 500 1816	02												
08 54 958 000 6130	02	08 54 973 800 1541	01	08 55 090 800 6142	01	08 55 189 600 1541	01	08 55 308 600 1816	02												
08 54 958 100 4310	01	08 54 973 800 1543	01	08 55 090 900 6142	01	08 55 189 700 1541	01	08 55 308 700 1816	04												
08 54 958 100 4310	02	08 54 973 900 1541	01	08 55 091 000 6142	01	08 55 208 000 6037	01	08 55 308 800 1816	02												
08 54 960 200 6145	01	08 54 973 900 1543	01	08 55 091 100 6142	02	08 55 242 700 1750	01	08 55 308 900 1816	02												
08 54 960 300 6142	01	08 54 974 200 1541	01	08 55 091 200 6142	02	08 55 253 000 1541	01	08 55 309 000 1816	02												
08 54 960 400 6142	01	08 54 974 200 1543	01	08 55 091 300 6142	01	08 55 253 200 1541	01	08 55 309 100 1816	01												
08 54 961 264 6037	01	08 54 978 300 1570	01	08 55 091 400 6142	01	08 55 253 300 1541	01	08 55 309 100 1816	02												
08 54 961 800 6045	02	08 54 978 500 6101	01	08 55 091 500 6142	01	08 55 253 900 1541	01	08 55 309 200 1816	01												
08 54 962 000 1816	01	08 54 978 500 6104	01	08 55 091 600 6142	01	08 55 253 900 1543	01	08 55 309 300 1816	02												
08 54 962 100 1833	01	08 54 978 600 6101	01	08 55 091 700 6142	01	08 55 254 000 1545	01	08 55 309 400 1816	02												
08 54 962 200 1833	01	08 54 978 600 6104	01	08 55 091 800 6142	01	08 55 254 100 1541	01	08 55 309 400 1816	06												
08 54 962 300 1833	01	08 54 978 700 6101	01	08 55 091 900 6142	03	08 55 254 200 1545	01	08 55 309 500 1816	01												
08 54 962 400 1833	01	08 54 978 700 6104	01	08 55 092 000 6142	01	08 55 254 300 1541	01	08 55 309 600 1816	01												
08 54 962 500 1833	01	08 54 979 600 6134	02	08 55 092 100 6142	01	08 55 254 300 1543	01	08 55 309 700 1816	01												
08 54 962 600 1833	01	08 54 981 300 5110	01	08 55 092 200 6142	01	08 55 254 400 1541	01	08 55 309 800 1816	01												
08 54 964 100 1610	01	08 54 981 900 5110	01	08 55 092 300 6142	01	08 55 254 400 1543	01	08 55 309 900 1816	01												
08 54 969 202 1430	10	08 54 988 700 1843	01	08 55 093 900 6145	01	08 55 256 300 6005	02	08 55 310 000 1816	01												
08 54 969 202 1430	14	08 54 988 900 1843	01	08 55 094 000 6145	01	08 55 261 700 6118	01	08 55 310 100 1816	01												

1 Numéro des pièces - Delnumre - Ersatzteilnummer - Part Number - Numeros de las piezas - Numero del pezzo - Nummers der onderdelen - Reservedelsnummer

2 Numéro des planches - Planché-Numre - Bildtafelnummer - Plate Number - Numeros de las laminas - Numero della tavola - Nummers der afbeeldingen - Bildnummer

3 Quantité par véhicule - Antal pr. vogn - Menge pro fahrzg - Quantity per vehicle - Cantidad por vehículo - Quantita per veicolo - Aant. per wagen - Antal per bil

			1			2			3			1			2			3		
08 55 310	200	1816	01	08 55 511	800	1541	01	08 55 610	300	5822	01	08 55 668	800	6134	02	08 55 811	900	3005	01	
08 55 310	300	1816	01	08 55 512	000	1540	01	08 55 617	700	4230	01	08 55 672	500	1833	01	08 55 811	999	3001	01	
08 55 310	400	1816	01	08 55 512	600	3001	01	08 55 617	800	4230	01	08 55 680	800	6145	01	08 55 811	999	3005	01	
08 55 310	500	1816	01	08 55 525	400	6138	01	08 55 617	900	4230	01	08 55 682	300	1540	01	08 55 812	000	3150	01	
08 55 310	600	1816	02	08 55 528	100	1816	01	08 55 617	999	4230	01	08 55 682	400	1570	01	08 55 812	100	3005	01	
08 55 310	700	1816	01	08 55 534	900	6230	01	08 55 618	000	4230	01	08 55 690	700	1543	01	08 55 812	199	3005	01	
08 55 310	800	1816	01	08 55 535	500	1860	04	08 55 618	099	4230	01	08 55 690	800	1543	01	08 55 816	800	1830	01	
08 55 310	900	1816	01	08 55 538	600	7001	02	08 55 618	100	4310	01	08 55 692	300	6065	01	08 55 816	900	1833	01	
08 55 311	000	1816	01	08 55 540	800	6031	02	08 55 619	400	4001	01	08 55 692	400	6065	01	08 55 824	000	6230	02	
08 55 311	100	1816	01	08 55 540	900	6031	04	08 55 619	500	4001	01	08 55 703	700	6130	04	08 55 835	000	6117	01	
08 55 311	200	1816	01	08 55 541	300	6031	02	08 55 619	600	4001	01	08 55 703	700	6134	04	08 55 835	100	6117	01	
08 55 311	500	1816	06	08 55 541	400	6031	02	08 55 619	700	4001	01	08 55 705	100	6001	01	08 55 835	200	6117	01	
08 55 311	600	1750	01	08 55 541	500	6031	02	08 55 619	800	4001	01	08 55 712	000	1840	01	08 55 835	300	6117	01	
08 55 378	100	1816	01	08 55 541	600	6031	02	08 55 619	900	4001	01	08 55 712	000	1840	02	08 55 836	400	1860	04	
08 55 482	300	1430	01	08 55 541	700	6031	02	08 55 620	100	4001	01	08 55 720	200	8901	02	08 55 843	900	6243	04	
08 55 483	900	1501	01	08 55 541	900	4401	05	08 55 620	200	4001	01	08 55 720	400	7001	01	08 55 844	700	6243	03	
08 55 487	500	6005	12	08 55 544	300	4001	01	08 55 620	300	4001	04	08 55 720	500	7001	02	08 55 871	100	1870	01	
08 55 487	500	6007	12	08 55 544	400	4001	01	08 55 620	400	4001	01	08 55 720	600	7001	01	08 55 874	500	5820	01	
08 55 491	100	1833	02	08 55 548	400	8545	02	08 55 620	500	4001	01	08 55 723	000	1870	02	08 55 891	000	1610	01	
08 55 493	500	1860	01	08 55 552	800	8430	12	08 55 620	600	4001	01	08 55 723	900	1870	01	08 55 914	600	8545	02	
08 55 497	400	5820	01	08 55 561	000	5110	02	08 55 620	700	4001	01	08 55 724	000	1870	02	08 55 914	600	8545	04	
08 55 497	600	5820	01	08 55 561	100	5110	02	08 55 620	800	6045	01	08 55 727	100	1843	01	08 55 927	000	6128	01	
08 55 497	700	5820	01	08 55 568	000	4401	05	08 55 620	800	6045	02	08 55 727	300	1843	01	08 55 932	000	5810	01	
08 55 498	400	6005	02	08 55 579	600	7801	01	08 55 635	700	1843	01	08 55 727	400	1843	01	08 55 939	800	5815	01	
08 55 498	500	6005	02	08 55 579	700	7801	01	08 55 643	400	4230	01	08 55 734	900	6138	01	08 55 946	700	6028	02	
08 55 498	600	6005	02	08 55 582	400	8180	01	08 55 643	500	4230	01	08 55 738	800	5830	01	08 55 946	700	6031	02	
08 55 498	700	6005	02	08 55 586	100	5820	01	08 55 643	600	4230	01	08 55 751	600	1843	02	08 55 959	900	7001	02	
08 55 502	200	6031	02	08 55 586	200	5822	01	08 55 649	000	1810	01	08 55 758	500	1541	01	08 57 531	200	8405	01	
08 55 502	300	6031	02	08 55 586	300	5822	01	08 55 650	400	5110	02	08 55 758	800	6128	01	08 57 531	300	8405	01	
08 55 502	400	6031	02	08 55 586	400	5820	01	08 55 650	500	5110	02	08 55 763	500	1843	01	08 57 538	200	1430	01	
08 55 509	400	6132	04	08 55 586	500	5820	01	08 55 651	900	6243	38	08 55 764	100	1843	02	08 57 549	600	8555	02	
08 55 509	400	8550	04	08 55 586	600	5820	01	08 55 652	000	6243	09	08 55 764	200	1843	02	08 57 553	700	3140	02	
08 55 510	800	3001	01	08 55 586	700	5820	01	08 55 662	700	1542	01	08 55 764	700	1843	01	08 57 557	000	3120	02	
08 55 510	899	3001	01	08 55 586	800	5820	01	08 55 664	400	6001	01	08 55 765	100	8545	01	08 57 560	000	8250	01	
08 55 510	900	1813	01	08 55 598	600	4310	01	08 55 667	200	1840	01	08 55 765	200	8545	01	08 57 576	200	8545	01	
08 55 511	300	1540	01	08 55 602	100	8430	10	08 55 667	300	1840	01	08 55 781	000	4001	01	08 57 615	300	3120	02	
08 55 511	400	1540	01	08 55 602	100	8430	12	08 55 667	900	1840	01	08 55 781	100	4001	01	08 57 617	000	8402	01	
08 55 511	500	1540	01	08 55 609	700	5820	01	08 55 668	400	1840	01	08 55 791	100	6240	03	08 57 617	012	8402	01	
08 55 511	600	1541	01	08 55 609	900	5820	01	08 55 668	800	1840	01	08 55 808	500	7801	01	08 57 631	600	1580	01	
08 55 511	700	1540	01	08 55 610	100	5820	01	08 55 668	800	6130	02	08 55 811	900	3001	01	08 57 640	400	6001	01	

1 Numéro des pièces - Delnumre - Ersatzteilnummer - Part Number - Numeros de las piezas - Numero del pezzo - Nummers der onderdelen - Reservdelsnummer

2 Numéro des planches - Planche-Numre - Bildtafelnummer - Plate Number - Numeros de las laminas - Numero della tavola - Nummers der afbeeldingen - Bildnummer

3 Quantité par véhicule - Antal pr. vogn - Menge pro fahrzg - Quantity per vehicle - Cantidad por vehículo - Quantita per veicolo - Aant. per wagen - Antal per bil

		1			2			3			1			2			3			
08 57 657 600 8221	01	08 70 268 700 6138	02	08 70 549 400 1750	01	09 50 576 200 6251	01	09 80 745 700 3130	01	08 57 704 100 1920	02	08 70 268 800 6138	02	08 70 575 200 1830	01	09 50 576 200 6252	01	09 80 754 100 3113	01	
08 70 000 100 6005	04	08 70 281 900 1816	01	08 70 596 100 4235	01	09 50 576 500 6251	01	09 80 754 200 3113	01	08 70 000 200 6138	01	08 70 284 300 5830	01	08 70 596 200 4235	01	09 50 576 500 6252	01	09 80 771 900 3130	01	
08 70 000 300 6138	01	08 70 292 500 6005	02	08 70 596 600 6065	01	09 50 576 900 6251	01	09 80 772 000 3101	01	08 70 000 300 6138	01	08 70 293 500 1813	01	08 70 608 800 5822	01	09 50 576 900 6252	01	09 80 772 100 3101	01	
08 70 000 400 6138	01	08 70 294 500 1833	01	08 70 608 800 5820	01	09 50 577 000 6251	01	09 80 777 200 3140	01	08 70 000 500 6138	01	08 70 294 500 1833	01	08 70 608 900 5820	01	09 50 577 000 6251	01	09 80 777 200 3140	01	
08 70 000 500 6138	01	08 70 306 600 3001	01	09 50 422 100 6250	01	09 50 577 000 6252	01	09 80 783 400 3101	01	08 70 000 600 6138	01	08 70 306 600 3001	01	09 50 422 100 6251	01	09 50 577 200 6251	01	09 80 783 400 3101	01	
08 70 000 700 6138	02	08 70 306 600 3005	01	09 50 422 100 6251	01	09 50 577 200 6251	01	09 80 783 499 3101	01	08 70 000 700 6138	02	08 70 306 600 3005	01	09 50 422 100 6252	01	09 50 577 200 6252	01	09 80 783 499 3101	01	
08 70 001 200 6138	01	08 70 308 400 6005	02	09 50 422 100 6252	01	09 50 577 200 6252	01	09 80 783 500 3101	01	08 70 001 200 6138	01	08 70 308 400 6005	02	09 50 422 200 6250	01	09 50 577 400 6252	01	09 80 783 500 3101	01	
08 70 002 300 6230	01	08 70 316 500 1833	01	09 50 422 200 6250	01	09 50 578 000 6251	01	09 81 668 300 4310	01	08 70 002 300 6230	01	08 70 316 500 1833	01	09 50 422 200 6251	01	09 50 578 000 6252	01	09 81 668 300 4310	01	
08 70 005 000 1542	01	08 70 317 200 6005	02	09 50 422 200 6252	01	09 50 578 000 6252	01	09 81 668 399 4310	01	08 70 005 000 1542	01	08 70 317 200 6005	02	09 50 422 200 6251	01	09 50 579 000 6251	01	09 81 668 399 4310	01	
08 70 005 100 1543	01	08 70 329 700 1830	01	09 50 425 700 6251	01	09 50 579 000 6251	01	09 81 668 400 4310	01	08 70 005 100 1543	01	08 70 329 700 1830	01	09 50 425 700 6251	01	09 50 579 000 6252	01	09 81 668 400 4310	01	
08 70 005 200 1542	01	08 70 340 100 6028	01	09 50 450 100 6250	01	09 50 579 000 6252	01	09 81 668 499 4310	01	08 70 005 200 1542	01	08 70 340 100 6028	01	09 50 450 100 6250	01	09 50 579 600 6251	01	09 81 668 499 4310	01	
08 70 005 300 1543	01	08 70 340 200 6028	01	09 50 454 300 6250	01	09 50 579 600 6251	01	09 81 682 000 4310	01	08 70 005 300 1543	01	08 70 340 200 6028	01	09 50 454 300 6251	01	09 50 579 600 6252	01	09 81 682 000 4310	01	
08 70 005 400 1543	01	08 70 381 100 5825	01	09 50 454 300 6251	01	09 80 616 700 1501	01	09 81 682 100 4310	01	08 70 005 400 1543	01	08 70 381 100 5825	01	09 50 454 300 6252	01	09 80 616 700 1501	01	09 81 682 100 4310	01	
08 70 005 500 1543	01	08 70 381 700 6005	02	09 50 454 300 6252	01	09 80 644 400 1601	01	09 81 695 800 4310	01	08 70 005 500 1543	01	08 70 381 700 6005	02	09 50 454 400 6250	01	09 80 644 400 1601	01	09 81 695 800 4310	01	
08 70 005 600 1543	01	08 70 404 200 1833	01	09 50 454 400 6250	01	09 80 649 100 1430	01	09 81 695 900 4310	01	08 70 005 600 1543	01	08 70 404 200 1833	01	09 50 454 400 6251	01	09 80 649 100 1430	01	09 81 735 000 4230	01	
08 70 005 700 1543	01	08 70 409 900 1833	01	09 50 454 400 6251	01	09 80 662 900 1530	01	09 81 735 100 4230	01	08 70 005 700 1543	01	08 70 409 900 1833	01	09 50 497 200 6250	01	09 80 663 000 1530	01	09 81 735 100 4230	01	
08 70 005 800 1543	01	08 70 416 400 1843	01	09 50 497 200 6250	01	09 80 663 000 1530	01	09 81 753 800 4230	01	08 70 005 800 1543	01	08 70 416 400 1843	01	09 50 497 900 6250	01	09 80 664 100 1405	01	09 81 753 800 4230	01	
08 70 005 900 1542	01	08 70 416 800 1843	01	09 50 498 100 6250	01	09 80 664 500 1405	01	09 81 948 800 4020	01	08 70 005 900 1542	01	08 70 416 800 1843	01	09 50 498 200 6250	01	09 80 664 900 1450	01	09 81 948 800 4020	01	
08 70 015 200 1840	01	08 70 419 200 6065	01	09 50 498 200 6250	01	09 80 665 000 1450	01	09 81 949 900 4030	01	08 70 015 200 1840	01	08 70 419 200 6065	01	09 50 498 200 6250	01	09 80 665 100 1450	01	09 81 949 900 4030	01	
08 70 025 000 1541	01	08 70 426 400 5822	01	09 50 498 800 6250	01	09 80 665 200 1450	01	09 81 949 300 4030	02	08 70 025 000 1541	01	08 70 426 400 5822	01	09 50 499 700 6250	01	09 80 665 300 1450	01	09 81 949 300 4030	02	
08 70 025 000 1543	01	08 70 502 100 1833	01	09 50 499 800 6250	01	09 80 665 300 1450	01	09 81 949 400 4030	01	08 70 025 000 1543	01	08 70 502 100 1833	01	09 50 513 800 6250	01	09 80 665 400 1450	01	09 81 949 400 4030	01	
08 70 046 800 4230	01	08 70 507 600 6116	01	09 50 513 800 6250	01	09 80 665 400 1450	01	09 81 950 800 4020	01	08 70 046 800 4230	01	08 70 507 600 6116	01	09 50 513 900 6250	01	09 80 665 900 1450	01	09 81 950 800 4020	01	
08 70 079 200 4001	01	08 70 507 700 6117	01	09 50 545 400 6250	01	09 80 666 000 1450	01	09 81 952 200 4020	01	08 70 079 200 4001	01	08 70 507 700 6117	01	09 50 545 600 6250	01	09 80 666 000 1450	01	09 81 952 200 4020	01	
08 70 079 300 4001	01	08 70 523 500 1830	01	09 50 545 600 6251	01	09 80 666 100 1450	01	09 81 959 000 4010	01	08 70 079 300 4001	01	08 70 523 500 1830	01	09 50 545 600 6251	01	09 80 666 100 1450	01	09 81 959 000 4010	01	
08 70 079 400 4001	01	08 70 523 900 1830	01	09 50 545 700 6250	01	09 80 666 400 1520	01	09 82 424 000 9145	01	08 70 079 400 4001	01	08 70 523 900 1830	01	09 50 545 700 6251	01	09 80 666 400 1520	01	09 82 424 000 9145	01	
08 70 079 500 4001	01	08 70 524 000 1830	01	09 50 545 800 6250	01	09 80 666 600 1520	01	09 83 209 900 7101	01	08 70 079 500 4001	01	08 70 524 000 1830	01	09 50 545 800 6250	01	09 80 666 600 1520	01	09 83 209 900 7101	01	
08 70 079 600 4001	01	08 70 524 100 1830	01	09 50 575 700 6251	01	09 80 667 100 1405	01	09 83 223 400 7101	01	08 70 079 600 4001	01	08 70 524 100 1830	01	09 50 575 700 6251	01	09 80 667 100 1405	01	09 83 223 400 7101	01	
08 70 079 700 4001	01	08 70 524 200 1830	01	09 50 575 700 6252	01	09 80 670 700 1530	01	09 83 734 300 1870	01	08 70 079 700 4001	01	08 70 524 200 1830	01	09 50 575 700 6252	01	09 80 670 700 1530	01	09 83 734 300 1870	01	
08 70 079 800 4001	01	08 70 535 100 1545	01	09 50 576 100 6251	01	09 80 680 700 1401	01	09 83 734 400 6250	01	08 70 079 800 4001	01	08 70 535 100 1545	01	09 50 576 100 6251	01	09 80 680 700 1401	01	09 83 734 400 6250	01	
08 70 079 900 4001	01	08 70 549 100 1750	01	09 50 576 100 6252	01	09 80 695 500 1701	01	09 83 734 500 6250	01	08 70 079 900 4001	01	08 70 549 100 1750	01	09 50 576 100 6252	01	09 80 695 500 1701	01	09 83 734 500 6250	01	
08 70 085 600 1830	01	08 70 549 300 1750	01	09 50 576 100 6252	01	09 80 745 600 3130	01	09 83 734 600 6250	01	08 70 085 600 1830	01	08 70 549 300 1750	01	09 50 576 100 6252	01	09 80 745 600 3130	01	09 83 734 600 6250	01	
08 70 085 700 1830	01									08 70 085 700 1830	01									
08 70 085 800 1830	01									08 70 085 800 1830	01									
08 70 112 200 6010	01									08 70 112 200 6010	01									
08 70 237 400 1843	01									08 70 237 400 1843	01									
08 70 268 400 6130	02									08 70 268 400 6130	02									

1 Numéro des pièces - Delnumre - Ersatzteilnummer - Part Number - Numeros de las piezas - Numero del pezzo - Nummern der onderdelen - Reservedelsnummer

2 Numéro des planches - Planche-Numre - Bildtafelnummer - Plate Number - Numeros de las laminas - Numero della tavola - Nummern der afbeeldingen - Bildnummer

3 Quantité par véhicule - Antal pr. vogn - Menge pro fahrzg - Quantity per vehicle - Cantidad por vehículo - Quantita per veicolo - Aant. per wagen - Antal per bil

				1			2			3			1			2			3		
09 82 734 800 6250	01	09 90 740 700 8130	01	09 94 210 900 8130	01	09 98 632 711 8410	01	09 98 763 991 8402	01												
09 83 734 900 6250	01	09 90 740 700 8135	01	09 94 210 900 8135	01	09 98 632 741 8405	01	09 98 774 700 8152	01												
09 83 735 CCC 6250	01	09 90 740 800 8130	01	09 94 513 900 6132	01	09 98 632 741 8410	01	10 50 040 080 6136	01												
09 83 761 900 6251	01	09 90 740 800 8135	01	09 94 514 000 6130	01	09 98 632 751 8405	01	10 70 050 302 6142	04												
09 83 762 000 6251	01	09 90 741 100 8130	01	09 94 514 200 6132	01	09 98 632 751 8410	01	10 81 100 854 4001	04												
09 83 762 100 6251	01	09 90 741 200 8136	01	09 94 515 400 6130	01	09 98 632 792 8405	01	10 81 101 242 8190	01												
09 83 762 200 6251	01	09 90 741 300 8138	01	09 94 517 800 6134	01	09 98 632 792 8410	01	10 81 110 452 1541	01												
09 83 762 300 6251	01	09 90 741 500 8135	01	09 94 519 500 6134	01	09 98 632 811 8405	01	10 81 110 452 1543	01												
09 83 762 500 6251	01	09 90 741 600 8136	01	09 96 001 500 1420	01	09 98 632 811 8410	01	10 81 110 452 6142	01												
09 83 762 6CC 6251	01	09 90 741 700 8130	01	09 96 018 600 1501	01	09 98 632 841 8405	01	10 81 110 452 6142	04												
09 83 770 600 6252	01	09 90 741 800 8150	01	09 96 019 200 1440	04	09 98 632 841 8410	01	10 81 110 452 6230	01												
09 83 770 800 6252	01	09 90 742 100 8150	01	09 96 019 300 1440	04	09 98 632 851 8405	01	10 81 110 452 6230	02												
09 83 771 000 6252	01	09 90 742 700 8138	01	09 96 019 400 1440	04	09 98 632 851 8410	01	10 81 110 452 8520	03												
09 83 771 200 6252	01	09 90 742 800 8138	01	09 96 019 500 1440	04	09 98 632 892 8405	01	10 81 110 472 6132	04												
09 83 771 400 6252	01	09 90 742 900 8135	01	09 96 020 300 1430	01	09 98 632 892 8410	01	10 81 110 472 6138	02												
09 83 771 600 6252	01	09 90 748 600 8138	01	09 96 035 100 1420	01	09 98 639 941 8410	01	10 81 110 472 8140	02												
09 83 772 000 6252	01	09 90 751 800 8130	01	09 96 044 100 4301	02	09 98 639 992 8410	01	10 81 110 472 8402	02												
09 83 772 200 6252	01	09 90 978 400 8205	01	09 96 064 900 1530	01	09 98 640 000 8430	01	10 81 110 472 8550	04												
09 84 236 600 5805	01	09 90 978 400 8210	01	09 96 066 100 3110	01	09 98 640 100 8430	01	10 81 110 552 1830	01												
09 84 236 700 5805	01	09 90 978 500 8205	01	09 96 066 200 3115	01	09 98 643 316 8430	01	10 81 110 552 6142	02												
09 84 738 400 6010	01	09 90 978 500 8210	01	09 96 080 000 4301	02	09 98 643 341 8430	01	10 81 110 552 6142	04												
09 84 738 500 6010	01	09 92 018 600 8105	01	09 96 093 700 1401	01	09 98 643 351 8430	01	10 81 110 552 6142	10												
09 84 740 600 6010	01	09 92 018 700 8110	01	09 96 093 800 1401	01	09 98 643 392 8430	01	10 81 110 552 8555	08												
09 84 745 500 6010	01	09 92 409 300 8230	01	09 96 094 300 3113	01	09 98 643 416 8430	01	10 81 110 572 6142	04												
09 84 753 600 6005	02	09 92 409 400 8221	01	09 96 094 400 3113	01	09 98 643 441 8430	01	10 81 110 572 8150	42												
09 84 760 200 6010	01	09 92 675 600 8117	01	09 96 096 900 1430	01	09 98 643 451 8430	01	10 81 110 572 8167	02												
09 84 760 300 6010	01	09 92 675 700 8117	01	09 96 112 800 4220	02	09 98 643 492 8430	01	10 81 110 572 8170	02												
09 84 510 000 7801	01	09 92 675 800 8120	01	09 96 112 899 4220	02	09 98 707 141 8402	01	10 81 110 652 1860	01												
09 87 104 300 8110	01	09 92 676 300 8120	01	09 96 126 200 8136	01	09 98 707 191 8402	01	10 81 110 652 1880	01												
09 88 003 000 1401	01	09 92 995 100 8145	02	09 96 126 300 8136	01	09 98 712 100 8402	01	10 81 110 652 5010	06												
09 88 505 300 8102	01	09 92 995 200 8145	02	09 96 126 400 8136	01	09 98 712 200 8402	02	10 81 110 652 5020	06												
09 88 505 301 8102	01	09 93 007 900 8117	01	09 96 126 500 8136	01	09 98 712 311 8402	01	10 81 110 652 5805	02												
09 88 505 302 8102	01	09 93 027 200 8120	01	09 96 136 900 4010	01	09 98 712 341 8402	01	10 81 110 652 5825	01												
09 88 505 303 8102	01	09 93 030 400 8117	01	09 96 143 100 1520	01	09 98 712 351 8402	01	10 81 110 652 6142	02												
09 88 505 304 8102	01	09 93 030 600 8120	01	09 96 143 200 1520	01	09 98 712 391 8402	01	10 81 110 652 8140	01												
09 88 512 300 8102	01	09 93 052 200 8117	01	09 96 143 300 1520	01	09 98 743 941 8405	01	10 81 110 652 8215	02												
09 88 512 301 8102	01	09 93 052 300 8120	01	09 96 143 400 1520	01	09 98 744 041 8405	01	10 81 110 662 1880	01												
09 88 512 302 8102	01	09 93 052 400 8120	01	09 98 632 441 8410	01	09 98 744 091 8405	01	10 81 110 662 8125	02												
09 90 215 800 8230	02	09 94 210 800 8130	01	09 98 632 492 8410	01	09 98 763 941 8402	01	10 81 110 662 8402	01												
09 90 433 900 8167	01	09 94 210 800 8135	01	09 98 632 711 8405	01																

1 Numéro des pièces - Delnumre - Ersatzteilnummer - Part Number - Numeros de las piezas - Numero del pezzo - Nummers der onderdelen - Reservdelsnummer

2 Numéro des planches - Planche-Numre - Bildtafelnummer - Plate Number - Numeros de las laminas - Numero della tavola - Nummers der afbeeldingen - Bildnummer

3 Quantité par véhicule - Antal pr. vogn - Menge pro fahrzg - Quantity per vehicle - Cantidad por vehículo - Quantita per veicolo - Aant. per wagen - Antal per bil

				1			2			3			1			2			3										
10	81	110	672	1580	01	10	81	200	446	6132	02	10	81	200	862	1860	02	10	81	201	646	1810	01	10	81	300	652	6240	07
10	81	110	672	6142	01	10	81	200	446	6134	02	10	81	200	862	1920	02	10	81	300	352	6035	01	10	81	300	652	8117	04
10	81	110	672	8130	01	10	81	200	462	1830	02	10	81	200	862	3001	06	10	81	300	452	1813	02	10	81	300	652	8120	04
10	81	110	672	8140	02	10	81	200	546	1830	02	10	81	200	862	4010	03	10	81	300	452	1840	01	10	81	300	652	8125	06
10	81	110	752	1575	01	10	81	200	546	1833	01	10	81	200	862	4201	04	10	81	300	452	1840	02	10	81	300	652	8130	01
10	81	110	752	3150	02	10	81	200	562	1830	02	10	81	200	862	4301	01	10	81	300	452	1843	01	10	81	300	652	8130	03
10	81	110	752	4010	02	10	81	200	562	6138	02	10	81	200	862	4301	12	10	81	300	452	6013	04	10	81	300	652	8152	02
10	81	110	752	5801	01	10	81	200	646	1816	02	10	81	200	862	5101	04	10	81	300	452	6028	06	10	81	300	652	8152	10
10	81	110	762	3110	02	10	81	200	646	1816	06	10	81	200	862	5201	02	10	81	300	452	6035	02	10	81	300	652	8255	03
10	81	110	772	8140	02	10	81	200	646	8221	06	10	81	200	862	5201	04	10	81	300	452	6058	07	10	81	300	652	8402	02
10	81	110	852	1830	02	10	81	200	662	1501	06	10	81	200	862	5801	04	10	81	300	452	6116	01	10	81	300	652	8520	04
10	81	110	852	3130	01	10	81	200	662	1701	10	10	81	200	862	5803	04	10	81	300	452	6116	02	10	81	300	652	8540	01
10	81	110	852	5805	02	10	81	200	662	1860	01	10	81	200	862	5810	01	10	81	300	452	6116	03	10	81	300	652	8540	04
10	81	110	852	7301	01	10	81	200	662	1880	02	10	81	200	862	5815	01	10	81	300	452	6117	01	10	81	300	652	8550	04
10	81	110	852	7301	02	10	81	200	662	3005	06	10	81	200	862	5820	02	10	81	300	452	6118	01	10	81	300	652	8555	04
10	81	110	852	7310	04	10	81	200	662	4010	02	10	81	200	862	5830	01	10	81	300	452	6132	04	10	81	300	652	8580	02
10	81	110	852	8215	04	10	81	200	662	5010	06	10	81	200	862	7001	02	10	81	300	452	6138	01	10	81	300	652	8590	02
10	81	110	862	1880	06	10	81	200	662	5020	06	10	81	200	862	7001	04	10	81	300	452	6230	02	10	81	300	852	6055	01
10	81	110	862	4001	04	10	81	200	662	5805	02	10	81	200	862	7101	03	10	81	300	452	8125	02	10	81	300	852	6055	02
10	81	110	862	5830	01	10	81	200	662	5810	01	10	81	200	862	7301	01	10	81	300	452	8135	23	10	81	300	852	6058	01
10	81	110	872	7001	02	10	81	200	662	5810	02	10	81	200	862	7301	02	10	81	300	452	8225	08	10	81	300	852	6061	01
10	81	110	872	7301	02	10	81	200	662	5810	04	10	81	200	862	7310	01	10	81	300	452	8550	04	10	81	300	852	6065	01
10	81	110	872	7310	02	10	81	200	662	5815	01	10	81	200	862	7310	02	10	81	300	552	1833	02	10	81	300	852	7301	02
10	81	111	052	3110	02	10	81	200	662	5815	02	10	81	200	862	7310	03	10	81	300	552	1860	02	10	81	300	852	7310	02
10	81	111	052	5201	02	10	81	200	662	5815	04	10	81	200	862	8145	04	10	81	300	552	6005	12	10	81	300	852	8152	08
10	81	111	052	6221	02	10	81	200	662	6128	02	10	81	200	862	8180	02	10	81	300	552	6007	12	10	81	300	862	7001	03
10	81	111	052	8230	02	10	81	200	662	7001	01	10	81	200	862	8190	02	10	81	300	552	6010	02	10	81	300	862	8135	02
10	81	111	062	8180	01	10	81	200	662	7001	02	10	81	200	862	8405	01	10	81	300	552	6025	04	10	81	300	862	8177	04
10	81	111	072	5201	02	10	81	200	662	8230	04	10	81	200	862	8410	01	10	81	300	552	6037	02	10	81	300	882	1880	03
10	81	111	072	8145	04	10	81	200	742	3113	02	10	81	201	062	1880	01	10	81	300	552	6136	01	10	81	301	052	3113	02
10	81	111	252	4301	04	10	81	200	742	3113	04	10	81	201	062	3110	02	10	81	300	552	6142	02	10	81	301	052	4201	02
10	81	111	252	8145	02	10	81	200	742	3150	02	10	81	201	062	4010	03	10	81	300	552	7001	04	10	81	301	052	8205	02
10	81	111	262	8105	02	10	81	200	762	4010	01	10	81	201	062	4020	03	10	81	300	552	8152	06	10	81	301	052	8210	02
10	81	111	262	8110	02	10	81	200	762	4210	06	10	81	201	062	4210	04	10	81	300	552	8221	12	10	81	301	062	8135	02
10	81	111	652	5201	02	10	81	200	762	5801	01	10	81	201	062	5010	02	10	81	300	562	8167	04	10	81	301	062	8135	04
10	81	112	056	4301	02	10	81	200	762	5830	02	10	81	201	062	5020	02	10	81	300	562	8170	04	10	81	301	062	8177	04
10	81	200	446	1816	01	10	81	200	842	1830	04	10	81	201	062	5101	10	10	81	300	562	8230	12	10	81	301	062	5201	02
10	81	200	446	1816	02	10	81	200	842	8501	03	10	81	201	062	8145	04	10	81	300	652	1810	03	10	81	301	252	8145	02
10	81	200	446	1843	03	10	81	200	862	1501	01	10	81	201	062	8221	02	10	81	300	652	6128	01	10	81	301	652	1813	01
10	81	200	446	6130	02	10	81	200	862	1530	02	10	81	201	062	8230	02	10	81	300	652	6142	02	10	81	310	452	6145	02

1 Numéro des pièces - Delnumre - Ersatzteilnummer - Part Number - Numeros de las piezas - Numero del pezzo - Nummers der onderdelen - Reservdelsnummer

2 Numéro des planches - Planche-Numre - Bildtafelnummer - Plate Number - Numeros de las laminas - Numero della tavola - Nummers der afbeeldingen - Bildnummer

3 Quantité par véhicule - Antal pr. vogn - Menge pro fahrg - Quantity per vehicle - Cantidad por vehículo - Quantita per veicolo - Aant. per wagen - Antal per bil

						1			2			3			1			2			3		
						1	2	3	1	2	3	1	2	3	1	2	3	1	2	3	1	2	3
10 81 310 552 6028	02	10 81 350 752 1880	01	10 98 342 192 8430	10	47 54 734 351 8401	XX	77 00 505 090 8105	01														
10 81 310 552 6031	02	10 81 350 762 1575	01	10 98 342 192 8550	03	47 54 734 388 8401	XX	77 00 505 105 5801	01														
10 81 310 552 6031	04	10 81 350 832 1501	06	10 98 342 192 8550	06	47 57 711 994 8401	XX	77 00 505 812 1860	01														
10 81 310 652 1510	02	10 81 350 852 1750	04	10 98 528 102 6007	04	47 57 721 994 8401	XX	77 00 505 883 8105	01														
10 81 310 652 1601	03	10 81 350 852 1860	01	10 98 535 132 6028	06	48 47 011 478 8401	XX	77 00 505 886 8125	01														
10 81 310 652 1601	04	10 81 350 852 6001	02	10 98 535 132 6035	02	77 00 500 472 4010	01	77 00 505 997 8901	01														
10 81 310 652 8215	02	10 81 350 852 6058	02	10 98 535 132 6101	04	77 00 500 923 8190	01	77 00 506 027 8117	01														
10 81 310 652 8540	01	10 81 350 852 6061	02	10 98 535 132 6104	02	77 00 500 924 8180	01	77 00 506 029 8140	01														
10 81 310 852 1575	02	10 81 350 852 6065	01	10 98 535 162 6013	04	77 00 500 925 8180	01	77 00 506 030 8240	01														
10 81 311 052 4220	02	10 81 350 852 8105	02	10 98 535 162 6230	01	77 00 500 928 8180	01	77 00 506 031 8240	01														
10 81 320 652 4210	06	10 81 350 852 8110	01	10 98 535 162 8402	02	77 00 501 480 8180	01	77 00 506 306 1501	01														
10 81 320 652 4301	06	10 81 350 852 8135	02	10 98 535 192 6040	02	77 00 501 740 4201	04	77 00 506 307 1501	01														
10 81 320 652 8215	03	10 81 350 852 8177	04	10 98 535 192 6040	04	77 00 501 740 4301	04	77 00 506 568 1501	01														
10 81 330 652 8205	06	10 81 350 852 8580	04	10 98 542 132 6138	01	77 00 502 278 3120	02	77 00 506 569 1501	01														
10 81 330 652 8210	06	10 81 351 052 8135	02	10 98 542 132 6138	02	77 00 502 279 3120	02	77 00 506 570 1501	01														
10 81 340 652 6101	02	10 88 020 150 5805	01	10 98 542 132 8117	06	77 00 502 401 1440	04	77 00 508 387 5201	01														
10 81 340 652 6104	02	10 88 020 150 5805	02	10 98 542 132 8120	06	77 00 502 402 1440	04	77 00 508 389 7310	01														
10 81 340 652 8105	11	10 88 025 150 8205	02	10 98 542 132 8140	02	77 00 503 629 7301	01	77 00 508 466 7301	01														
10 81 340 652 8110	11	10 88 025 150 8210	02	10 98 542 132 8152	04	77 00 503 631 7301	01	77 00 508 984 8140	01														
10 81 340 652 8140	02	10 89 020 152 5801	01	10 98 542 132 8175	02	77 00 503 633 7301	01	77 00 509 345 7301	01														
10 81 340 652 8585	04	10 89 020 152 5803	01	10 98 542 132 8177	02	77 00 503 646 4225	02	77 00 509 485 5810	01														
10 81 341 052 8580	06	10 89 020 152 5810	01	10 98 542 132 8520	03	77 00 503 745 3113	01	77 00 509 485 5815	01														
10 81 341 052 8585	06	10 89 020 152 5815	01	10 98 542 132 8901	04	77 00 504 131 8105	01	77 00 509 849 8130	01														
10 81 350 452 8140	08	10 89 020 200 4010	04	10 98 542 132 8901	18	77 00 504 140 5803	01	77 00 509 849 8130	02														
10 81 350 452 8205	02	10 89 020 202 1530	01	10 98 542 162 8135	23	77 00 504 141 5803	01	77 00 509 849 8135	01														
10 81 350 452 8210	02	10 89 020 250 4030	04	10 98 548 132 6005	12	77 00 504 352 5801	01	77 00 509 849 8135	02														
10 81 350 552 6001	02	10 89 030 352 4301	02	10 98 548 132 6007	12	77 00 504 353 5801	01	77 00 510 599 8550	01														
10 81 350 552 6001	05	10 89 030 400 4210	02	10 98 555 162 8140	10	77 00 504 361 8501	01	77 00 510 599 8550	02														
10 81 350 552 8125	04	10 89 040 450 4020	02	10 98 555 162 8555	06	77 00 504 575 7301	01	77 00 510 652 7001	01														
10 81 350 552 8140	02	10 89 040 450 4030	04	38 01 824 000 5825	01	77 00 504 578 7301	01	77 00 512 603 8225	02														
10 81 350 552 8221	01	10 89 050 550 5803	01	38 01 834 000 7101	01	77 00 504 717 8105	01	77 00 513 657 8140	01														
10 81 350 552 8230	01	10 98 328 162 8240	18	47 54 534 132 8401	XX	77 00 504 718 8125	02	77 00 513 657 8175	01														
10 81 350 552 8520	10	10 98 328 162 8250	06	47 54 534 140 8401	XX	77 00 504 801 7310	01	77 00 513 657 8177	01														
10 81 350 652 8140	08	10 98 335 132 8105	05	47 54 534 401 8401	XX	77 00 504 858 5010	01	77 00 513 659 8117	02														
10 81 350 652 8501	04	10 98 335 132 8110	05	47 54 634 066 8401	XX	77 00 504 961 8140	01	77 00 513 659 8120	02														
10 81 350 662 8250	01	10 98 335 134 8167	06	47 54 634 067 8401	XX	77 00 504 966 1750	01	77 00 513 859 8205	01														
10 81 350 672 1860	01	10 98 335 162 8430	10	47 54 634 397 8401	XX	77 00 505 014 8167	01	77 00 513 859 8210	01														
10 81 350 732 3110	02	10 98 335 162 8430	12	47 54 634 400 8401	XX	77 00 505 014 8170	01	77 00 513 860 8152	10														
10 81 350 732 3113	08	10 98 342 132 8225	02	47 54 734 234 8401	XX	77 00 505 015 8167	01	77 00 513 861 8152	10														
10 81 350 752 1860	02	10 98 342 132 8430	21	47 54 734 235 8401	XX	77 00 505 015 8170	01	77 00 513 862 8125	01														

1 Numéro des pièces - Delnumre - Ersatzteilnummer - Part Number - Numeros de las piezas - Numero del pezzo - Nummers der onderdelen - Reservdelsnummer

2 Numéro des planches - Planche-Numre - Bildtafelnummer - Plate Number - Numeros de las laminas - Numero della tavola - Nummers der afbeeldingen - Bildnummer

3 Quantité par véhicule - Antal pr. vogn - Menge pro fahrzg - Quantity per vehicle - Cantidad por vehículo - Quantita per veicolo - Aant. per wagen - Antal per bil

				1			2			3			1			2			3					
77 00	513	911	8402	01	77 01	002	536	4225	01	77 01	498	013	4225	02	77 03	001	118	5805	02	77 03	001	129	8501	02
77 00	514	895	6240	03	77 01	002	537	4225	01	77 01	498	024	3101	01	77 03	001	118	8105	11	77 03	001	132	1701	01
77 00	516	212	8205	C2	77 01	002	538	4225	01	77 01	498	026	3101	01	77 03	001	118	8110	11	77 03	001	136	1570	01
77 00	516	212	8210	02	77 01	002	539	4225	04	77 01	500	004	4010	01	77 03	001	118	8152	02	77 03	001	136	3110	02
77 00	518	534	1843	01	77 01	002	770	6136	01	77 01	500	577	8402	01	77 03	001	118	8501	02	77 03	001	136	3113	04
77 00	518	534	1845	01	77 01	003	729	1813	01	77 01	500	578	8402	01	77 03	001	118	8540	04	77 03	001	140	1575	01
77 00	518	676	1501	01	77 01	003	876	1813	01	77 01	500	579	8410	01	77 03	001	118	8580	02	77 03	001	140	3113	02
77 00	519	829	1501	01	77 01	005	248	6132	02	77 01	500	580	8410	01	77 03	001	120	5810	01	77 03	001	140	3113	08
77 00	520	332	1440	01	77 01	006	143	1830	01	77 01	500	581	8410	01	77 03	001	120	5810	04	77 03	001	140	3150	02
77 00	520	332	1440	01	77 01	006	143	1830	01	77 01	500	581	8410	01	77 03	001	120	5810	04	77 03	001	140	3150	02
77 00	520	332	1440	01	77 01	006	143	1830	01	77 01	500	581	8410	01	77 03	001	120	5810	04	77 03	001	140	3150	02
77 00	520	332	1440	01	77 01	006	143	1830	01	77 01	500	581	8410	01	77 03	001	120	5810	04	77 03	001	140	3150	02
77 00	520	332	1440	01	77 01	006	143	1830	01	77 01	500	581	8410	01	77 03	001	120	5810	04	77 03	001	140	3150	02
77 00	520	332	1440	01	77 01	006	143	1830	01	77 01	500	581	8410	01	77 03	001	120	5810	04	77 03	001	140	3150	02
77 00	520	332	1440	01	77 01	006	143	1830	01	77 01	500	581	8410	01	77 03	001	120	5810	04	77 03	001	140	3150	02
77 00	520	332	1440	01	77 01	006	143	1830	01	77 01	500	581	8410	01	77 03	001	120	5810	04	77 03	001	140	3150	02
77 00	520	332	1440	01	77 01	006	143	1830	01	77 01	500	581	8410	01	77 03	001	120	5810	04	77 03	001	140	3150	02
77 00	520	332	1440	01	77 01	006	143	1830	01	77 01	500	581	8410	01	77 03	001	120	5810	04	77 03	001	140	3150	02
77 00	520	332	1440	01	77 01	006	143	1830	01	77 01	500	581	8410	01	77 03	001	120	5810	04	77 03	001	140	3150	02
77 00	520	332	1440	01	77 01	006	143	1830	01	77 01	500	581	8410	01	77 03	001	120	5810	04	77 03	001	140	3150	02
77 00	520	332	1440	01	77 01	006	143	1830	01	77 01	500	581	8410	01	77 03	001	120	5810	04	77 03	001	140	3150	02
77 00	520	332	1440	01	77 01	006	143	1830	01	77 01	500	581	8410	01	77 03	001	120	5810	04	77 03	001	140	3150	02
77 00	520	332	1440	01	77 01	006	143	1830	01	77 01	500	581	8410	01	77 03	001	120	5810	04	77 03	001	140	3150	02
77 00	520	332	1440	01	77 01	006	143	1830	01	77 01	500	581	8410	01	77 03	001	120	5810	04	77 03	001	140	3150	02
77 00	520	332	1440	01	77 01	006	143	1830	01	77 01	500	581	8410	01	77 03	001	120	5810	04	77 03	001	140	3150	02
77 00	520	332	1440	01	77 01	006	143	1830	01	77 01	500	581	8410	01	77 03	001	120	5810	04	77 03	001	140	3150	02
77 00	520	332	1440	01	77 01	006	143	1830	01	77 01	500	581	8410	01	77 03	001	120	5810	04	77 03	001	140	3150	02
77 00	520	332	1440	01	77 01	006	143	1830	01	77 01	500	581	8410	01	77 03	001	120	5810	04	77 03	001	140	3150	02
77 00	520	332	1440	01	77 01	006	143	1830	01	77 01	500	581	8410	01	77 03	001	120	5810	04	77 03	001	140	3150	02
77 00	520	332	1440	01	77 01	006	143	1830	01	77 01	500	581	8410	01	77 03	001	120	5810	04	77 03	001	140	3150	02
77 00	520	332	1440	01	77 01	006	143	1830	01	77 01	500	581	8410	01	77 03	001	120	5810	04	77 03	001	140	3150	02
77 00	520	332	1440	01	77 01	006	143	1830	01	77 01	500	581	8410	01	77 03	001	120	5810	04	77 03	001	140	3150	02
77 00	520	332	1440	01	77 01	006	143	1830	01	77 01	500	581	8410	01	77 03	001	120	5810	04	77 03	001	140	3150	02
77 00	520	332	1440	01	77 01	006	143	1830	01	77 01	500	581	8410	01	77 03	001	120	5810	04	77 03	001	140	3150	02
77 00	520	332	1440	01	77 01	006	143	1830	01	77 01	500	581	8410	01	77 03	001	120	5810	04	77 03	001	140	3150	02
77 00	520	332	1440	01	77 01	006	143	1830	01	77 01	500	581	8410	01	77 03	001	120	5810	04	77 03	001	140	3150	02
77 00	520	332	1440	01	77 01	006	143	1830	01	77 01	500	581	8410	01	77 03	001	120	5810	04	77 03	001	140	3150	02
77 00	520	332	1440	01	77 01	006	143	1830	01	77 01	500	581	8410	01	77 03	001	120	5810	04	77 03	001	140	3150	02
77 00	520	332	1440	01	77 01	006	143	1830	01	77 01	500	581	8410	01	77 03	001	120	5810	04	77 03	001	140	3150	02
77 00	520	332	1440	01	77 01	006	143	1830	01	77 01	500	581	8410	01	77 03	001	120	5810	04	77 03	001	140	3150	02
77 00	520	332	1440	01	77 01	006	143	1830	01	77 01	500	581	8410	01	77 03	001	120	5810	04	77 03	001	140	3150	02
77 00	520	332	1440	01	77 01	006	143	1830	01	77 01	500	581	8410	01	77 03	001	120	5810	04	77 03	001	140	3150	02
77 00	520	332	1440	01	77 01	006	143	1830	01	77 01	500	581	8410	01	77 03	001	120	5810	04	77 03	001	140	3150	02
77 00	520	332	1440	01	77 01	006	143	1830	01	77 01	500	581	8410	01	77 03	001	120	5810	04	77 03	001	140	3150	02
77 00	520	332	1440	01	77 01	006	143	1830	01	77 01	500	581	8410	01	77 03	001	120	5810	04	77 03	001	140	3150	02
77 00	520	332	1440	01	77 01	006	143	1830	01	77 01	500	581	8410	01	77 03	001	120	5810	04	77 03	001	140	3150	02
77 00	520	332	1440	01	77 01	006	143	1830	01	77 01	500	581	8410	01	77 03	001	120	5810	04	77 03	001	140	3150	02
77 00	520	332	1440	01	77 01	006	143	1830	01	77 01	500	581	8410	01	77 03	001	120	5810	04	77 03	001	140	3150	02
77 00	520	332	1440	01	77 01	006	143	1830	01	77 01	500	581	8410	01	77 03	001	120	5810	04	77 03	001	140	3150	02
77 00	520	332	1440	01	77 01	006	143	1830	01	77 01	500	581	8410	01	77 03	001	120	5810	04	77 03	001	140	3150	02
77 00	520	332	1440	01	77 01	006	143	1830	01	77 01	500	581	8410	01	77 03	001	120	5810	04	77 03	001	140	3150	02
77 00	520	332	1440	01	77 01	006	143	1830	01	77 01	500	581	8410	01	77 03	001	120	5810	04	77 03	001	140	3150	02
77 00	520	332	1440	01	77 01	006	143	1830	01	77 01	500	581	8410	01	77 03	001	120	5810	04	77 03	001	140	3150	02
77 00	520	332	1440	01	77 01	006	143	1830	01	77 01	500	581	8410	01	77 03	001	120	5810	04	77 03	001	140	3150	02
77 00	520	332	1440	01	77 01	006	143	1830	01	77 01	500	581	8410	01	77 03	001	120	5810						

1 Numéro des pièces - Delnumre - Ersatzteilnummer - Part Number - Numeros de las piezas - Numero del pezzo - Nummers der onderdelen - Reservedelsnummer

2 Numéro des planches - Planche-Numre - Bildtafelnummer - Plate Number - Numeros de las laminas - Numero della tavola - Nummers der afbeeldingen - Bildnummer

3 Quantité par véhicule - Antal pr. vogn - Menge pro fahrzg - Quantity per vehicle - Cantidad por vehículo - Quantita per veicolo - Aant. per wagen - Antal per bil

			1			2			3			1			2			3											
77	03	001	160	8180	02	77	03	001	196	1880	01	77	03	001	379	3005	05	80	70	040	082	6061	06	80	80	100	552	1833	02
77	03	001	160	8190	02	77	03	001	196	4210	04	77	03	001	402	8130	01	80	70	040	082	6136	01	80	80	100	552	6001	02
77	03	001	162	4301	04	77	03	001	196	5010	02	80	16	070	252	1430	01	80	70	040	082	6145	02	80	80	100	552	6001	05
77	03	001	162	5801	04	77	03	001	196	5020	02	80	23	040	102	6058	02	80	70	040	122	1843	02	80	80	100	552	6138	02
77	03	001	162	5803	02	77	03	001	202	8105	02	80	23	040	102	6118	01	80	70	040	152	6136	04	80	80	100	552	7001	04
77	03	001	162	5820	02	77	03	001	202	8110	02	80	23	040	102	8125	02	80	70	040	152	6145	04	80	80	100	552	8520	06
77	03	001	162	5830	01	77	03	001	209	8145	02	80	23	040	102	8205	02	80	70	040	352	1833	01	80	80	100	552	8555	08
77	03	001	162	7301	01	77	03	001	242	4010	01	80	23	040	102	8210	02	80	70	050	102	1901	08	80	80	100	642	1810	03
77	03	001	162	7310	02	77	03	001	243	4010	01	80	23	040	102	8225	08	80	70	050	152	6031	04	80	80	100	642	1813	02
77	03	001	162	8135	02	77	03	001	243	4020	03	80	23	040	162	6142	01	80	70	060	122	4210	06	80	80	100	642	1833	02
77	03	001	162	8152	08	77	03	001	244	4010	01	80	23	040	162	8140	10	80	70	060	122	4301	06	80	80	100	642	8215	02
77	03	001	162	8177	04	77	03	001	253	3110	11	80	23	040	202	6132	04	80	71	060	250	8540	01	80	80	100	642	8255	03
77	03	001	164	7301	01	77	03	001	254	3110	01	80	23	050	102	7001	04	80	72	040	152	6230	02	80	80	100	652	1701	03
77	03	001	165	1880	02	77	03	001	255	3110	04	80	23	050	102	8167	04	80	72	050	122	6028	06	80	80	100	652	1701	10
77	03	001	165	5810	01	77	03	001	256	3110	01	80	23	050	102	8170	04	80	72	050	152	6010	02	80	80	100	652	1880	01
77	03	001	165	5815	01	77	03	001	261	3110	01	80	23	050	102	8221	01	80	72	050	152	6025	04	80	80	100	652	4010	02
77	03	001	167	5803	01	77	03	001	264	3110	01	80	23	050	102	8230	01	80	72	060	152	8255	03	80	80	100	652	5801	01
77	03	001	167	8501	03	77	03	001	264	4010	03	80	23	050	252	6142	01	80	72	060	202	8240	02	80	80	100	652	5803	01
77	03	001	188	8135	02	77	03	001	265	3110	01	80	23	050	252	6142	02	80	75	060	202	8215	03	80	80	100	652	5805	02
77	03	001	170	1880	01	77	03	001	309	3113	04	80	61	050	102	6028	04	80	75	850	204	8205	04	80	80	100	652	5810	01
77	03	001	173	7301	01	77	03	001	329	4010	02	80	61	050	152	8221	02	80	75	850	204	8210	04	80	80	100	652	5810	02
77	03	001	174	7301	01	77	03	001	360	4301	08	80	61	050	152	8230	02	80	75	950	204	8215	02	80	80	100	652	5810	04
77	03	001	174	7310	03	77	03	001	368	3113	02	80	61	060	202	8225	12	80	80	100	442	1830	02	80	80	100	652	5815	01
77	03	001	182	4220	02	77	03	001	368	3150	02	80	61	060	352	8590	02	80	80	100	442	1833	01	80	80	100	652	5815	02
77	03	001	182	8580	02	77	03	001	368	4210	06	80	61	060	502	8590	01	80	80	100	442	6055	06	80	80	100	652	5815	04
77	03	001	183	4210	08	77	03	001	368	5830	02	80	63	040	102	6128	02	80	80	100	442	6142	05	80	80	100	652	5825	01
77	03	001	183	5201	02	77	03	001	369	1833	02	80	63	040	122	8205	06	80	80	100	452	6028	06	80	80	100	652	6101	02
77	03	001	183	8135	02	77	03	001	369	6138	01	80	63	040	122	8210	06	80	80	100	452	6118	01	80	80	100	652	6104	02
77	03	001	183	8177	04	77	03	001	369	6138	02	80	63	060	102	8205	06	80	80	100	452	8125	02	80	80	100	652	6128	01
77	03	001	185	4010	02	77	03	001	369	6142	01	80	63	060	102	8210	06	80	80	100	542	1830	02	80	80	100	652	6142	02
77	03	001	185	4225	02	77	03	001	369	6142	02	80	63	060	152	4210	06	80	80	100	542	1833	01	80	80	100	652	7001	01
77	03	001	186	8135	04	77	03	001	369	8125	04	80	63	060	152	4301	06	80	80	100	542	1833	02	80	80	100	652	8130	01
77	03	001	189	3110	02	77	03	001	369	8167	02	80	70	030	122	6031	04	80	80	100	542	6028	02	80	80	100	652	8130	03
77	03	001	189	5010	02	77	03	001	369	8170	02	80	70	040	062	1843	02	80	80	100	542	6031	02	80	80	100	652	8140	02
77	03	001	189	5020	02	77	03	001	369	8221	04	80	70	040	062	4001	01	80	80	100	542	6031	04	80	80	100	652	8501	02
77	03	001	189	8135	02	77	03	001	369	8230	04	80	70	040	062	6055	06	80	80	100	542	6136	01	80	80	100	652	8540	01
77	03	001	190	8585	06	77	03	001	369	8520	04	80	70	040	062	6061	06	80	80	100	542	6142	02	80	80	100	652	8555	04
77	03	001	192	4201	08	77	03	001	374	5201	02	80	70	040	082	1813	02	80	80	100	542	8125	04	80	80	100	652	8580	02
77	03	001	194	5010	02	77	03	001	379	1501	06	80	70	040	082	6013	04	80	80	100	542	8152	06	80	80	100	652	8590	03
77	03	001	194	5020	02	77	03	001	379	1580	01	80	70	040	082	6055	06	80	80	100	552	1575	02	80	80	100	742	8140	02

1 Numéro des pièces - Delnumre - Ersatzteilnummer - Part Number - Numeros de las piezas - Numero del pezzo - Nummers der onderdelen - Reservdelsnummer

2 Numéro des planches - Planche-Numre - Bildtafelnummer - Plate Number - Numeros de las laminas - Numero della tavola - Nummers der afbeeldingen - Bildnummer

3 Quantité par véhicule - Antal pr. vogn - Menge pro fahrzg - Quantity per vehicle - Cantidad por vehículo - Quantita per veicolo - Aant. per wagen - Antal per bil

						1			2			3			1			2			3								
80	80	100	752	1510	02	80	80	100	852	7310	03	80	83	100	552	8221	02	08	54	954	600	1845	01	77	01	452	858	1401	01
80	80	100	752	1575	01	80	80	100	852	8145	04	80	83	100	842	3130	01	08	54	989	300	1845	01	77	01	453	025	8102	01
80	80	100	752	1860	02	80	80	100	852	8177	04	80	83	100	842	4201	04	08	55	672	600	1833	01	77	01	453	026	8102	01
80	80	100	752	1880	01	80	80	100	852	8501	03	80	83	100	842	4210	04	08	55	672	900	1833	02	77	01	453	027	8102	01
80	80	100	752	4010	01	80	80	100	852	8580	04	80	83	100	842	5101	02	08	55	673	400	1833	01	77	01	453	028	8102	01
80	80	100	752	5801	01	80	80	100	852	8585	04	80	83	100	842	8205	02	08	55	727	100	1845	01	77	01	453	033	4225	02
80	80	100	752	8140	02	80	80	101	042	4201	02	80	83	100	842	8210	02	08	55	727	300	1845	01	77	01	499	026	3001	01
80	80	100	842	1830	02	80	80	101	052	1880	01	80	83	101	042	4010	03	08	55	764	700	1845	01	77	01	499	029	3005	01
80	80	100	842	6055	01	80	80	101	052	3110	01	80	83	101	042	4201	08	08	55	819	300	6001	01	77	01	499	035	3001	01
80	80	100	842	6058	01	80	80	101	052	3110	02	80	83	101	042	4301	08	08	55	919	600	6001	01	77	01	499	035	3005	01
80	80	100	842	6061	01	80	80	101	052	3113	01	80	83	101	042	5010	04	08	70	410	000	1833	01	77	01	499	045	4230	01
80	80	100	842	6065	01	80	80	101	052	4010	02	80	83	101	042	5020	04	10	81	200	462	1845	02	77	01	499	053	4230	01
80	80	100	852	1830	02	80	80	101	052	4210	04	80	83	101	042	5201	02	10	81	200	646	1833	02	77	01	499	057	4310	01
80	80	100	852	1880	03	80	80	101	052	5010	02	80	83	101	052	5201	02	77	00	505	115	1510	04	77	01	499	061	4310	01
80	80	100	852	4010	03	80	80	101	052	5020	02	80	83	101	242	8105	02	77	00	505	499	1601	01	77	01	506	600	1601	01
80	80	100	852	4201	04	80	80	101	052	5101	10	80	83	101	242	8110	02	77	00	507	921	8125	01	77	01	508	140	8102	01
80	80	100	852	4301	01	80	80	101	052	8145	04	80	83	101	442	4201	06	77	00	507	925	8125	01	77	01	508	141	8102	01
80	80	100	852	4301	06	80	80	101	052	8177	04	80	83	101	442	4210	08	77	00	507	928	8125	01	77	03	001	122	1833	02
80	80	100	852	5101	04	80	80	101	052	8221	02	80	83	101	452	4201	02	77	00	507	929	8125	01	79	03	056	008	1833	02
80	80	100	852	5201	04	80	80	101	052	8230	02	80	83	101	642	4301	02	77	00	509	768	1510	08	79	03	032	070	1833	02
80	80	100	852	5801	01	80	80	101	052	8580	04	80	83	111	242	4301	04	77	00	509	769	1510	08	80	70	040	062	1845	01
80	80	100	852	5801	02	80	80	101	052	8580	06	80	83	111	242	4301	08	77	00	509	770	1510	08	80	70	040	122	1845	02
80	80	100	852	5801	04	80	80	101	052	8585	06	80	83	111	452	4201	04	77	00	509	771	1510	04						
80	80	100	852	5803	02	80	80	101	252	8145	02	80	83	120	852	5201	02	77	00	512	369	1601	01						
80	80	100	852	5803	04	80	80	101	452	4201	08							77	00	517	058	1430	01						
80	80	100	852	5810	01	80	80	101	652	5201	02							77	00	519	278	1501	06						
80	80	100	852	5815	01	80	80	101	652	5201	04							77	00	519	279	1501	01						
80	80	100	852	5820	02	80	80	110	752	3110	20							77	00	525	087	1510	01						
80	80	100	852	6001	02	80	80	120	440	6058	02							77	01	001	675	1845	01						
80	80	100	852	6055	02	80	80	120	450	6116	03							77	01	004	900	1845	01						
80	80	100	852	6058	02	80	80	120	550	6037	02	08	51	847	500	1845	01	77	01	004	901	1845	01						
80	80	100	852	6061	02	80	80	120	550	6136	01	08	51	874	100	1845	01	77	01	004	902	1845	01						
80	80	100	852	6065	01	80	80	160	852	1830	02	08	53	712	500	1845	01	77	01	004	903	1845	01						
80	80	100	852	7001	02	80	80	170	852	4010	04	08	53	829	300	1845	02	77	01	004	907	1845	01						
80	80	100	852	7001	03	80	80	200	652	8125	06	08	54	120	600	1845	01	77	01	009	059	6045	01						
80	80	100	852	7001	04	80	80	201	052	8205	02	08	54	268	900	1845	01	77	01	452	189	1501	01						
80	80	100	852	7301	01	80	80	201	052	8210	02	08	54	355	500	1845	01	77	01	452	697	1430	01						
80	80	100	852	7301	02	80	80	310	852	8405	01	08	54	367	800	1845	01	77	01	452	855	1401	01						
80	80	100	852	7310	01	80	80	310	852	8410	01	08	54	465	400	1845	01	77	01	452	856	1401	01						
80	80	100	852	7310	02	80	83	100	552	6142	02	08	54	725	300	1845	04	77	01	452	857	1401	01						

**130.50****130.50**

<p style="text-align: center;"><i>FRANÇAIS</i></p> <p>Tous les droits d'auteur sont réservés à la Régie Nationale des Usines Renault. La reproduction ou la traduction même partielle du présent catalogue ainsi que l'utilisation du système de numérotage de référence des pièces de rechange sont interdites sans l'autorisation écrite et préalable de la Régie Nationale des Usines Renault.</p> <p>©Régie Nationale des Usines RENAULT 1970</p>	<p style="text-align: center;"><i>DANSK</i></p> <p>Alle ophavsrettigheder tilhører Régie Nationale des Usines Renault. Gengivelse eller oversættelse, også i uddrag, af dette katalog samt anvendelse af reservedelens nummereringssystem er ikke tilladt uden skriftlig tilladelse fra Régie Nationale des Usines Renault.</p> <p>©Régie Nationale des Usines RENAULT 1970</p>	<p style="text-align: center;"><i>DEUTSCH</i></p> <p>Sämtliche Urheberrechte liegen bei der Régie Nationale des Usines Renault. Nachdruck oder Übersetzung, selbst auszugsweise, des vorliegenden Kataloges sowie die Verwendung der Ersatzteilnummern und des Numerierungssystems sind nicht gestattet ohne besondere schriftliche Genehmigung der Régie Nationale des Usines Renault.</p> <p>©Régie Nationale des Usines RENAULT 1970</p>
<p style="text-align: center;"><i>ENGLISH</i></p> <p>All copyrights reserved by the Régie Nationale des Usines Renault. Copying or translation, in part or in full of this catalogue or use of the spare part reference numerotation system is forbidden without the prior written authority of the Régie Nationale des Usines Renault.</p> <p>©Régie Nationale des Usines RENAULT 1970</p>	<p style="text-align: center;"><i>ESPAÑOL</i></p> <p>La Régie Nationale des Usines Renault se reserva todos los derechos de autor. Queda prohibida la reproducción, o la traducción, incluso parcial, del presente catálogo, así como la utilización del sistema de numeración de referencia de las piezas de repuesto, sin la autorización por escrito de la Régie Nationale des Usines Renault.</p> <p>©Régie Nationale des Usines RENAULT 1970</p>	<p style="text-align: center;"><i>ITALIANO</i></p> <p>Tutti i diritti d'autore sono riservati alla Régie Nationale des Usines Renault. La riproduzione o la traduzione anche parziali del presente catalogo come pure l'utilizzazione del sistema di numerazione di riferimento delle parti di ricambio sono vietate senza previa autorizzazione scritta della Régie Nationale des Usines Renault.</p> <p>©Régie Nationale des Usines RENAULT 1970</p>
<p style="text-align: center;"><i>NEERLANDS</i></p> <p>Alle auteursrechten zijn voorbehouden aan de Régie Nationale des Usines Renault. Reproduceren en/of vertalen, zelfs gedeeltelijk, van deze catalogus evenals het overnemen van indeling van dit boek en/of wijze van aanduiding der onderdelen is verboden zonder vooraf ontvangen schriftelijke goedkeuring van de Régie Nationale des Usines Renault.</p> <p>©Régie Nationale des Usines RENAULT 1970</p>		<p style="text-align: center;"><i>SVENSKA</i></p> <p>Samtliga rättigheter förbehålls oinskränkta Régie Nationale des Usines Renault. Eftertryck eller delvis översättning av denna reservdelskatalog samt användning av referenssystemet för numrering av reservdelar är förbjudna utan skriftligt tillstånd från Régie Nationale des Usines Renault.</p> <p>©Régie Nationale des Usines RENAULT 1970</p>

Der Franzose